

**WB JEE Engineering Entrance Exam**
**SOLVED PAPER – 2021**
**Physics**
**Category-I (Q. Nos. 1 to 30)**

Carry 1 mark each and only one option is correct. In case of incorrect answer or any combination of more than one answer, 1/4 mark will be deducted.

1. A spherical convex surface of power 5 D separates object and image space of refractive indices 1.0 and  $\frac{4}{3}$ , respectively. The radius of curvature of the surface is

(a) 20 cm (b) 1 cm (c) 4 cm (d) 5 cm

2. In Young's double slit experiment, light of wavelength  $\lambda$  passes through the double slit and forms interference fringes on a screen 1.2 m away. If the difference between 3rd order maximum and 3rd order minimum is 0.18 cm and the slits are 0.02 cm apart, then  $\lambda$  is

(a) 1200 nm (b) 450 nm  
(c) 600 nm (d) 300 nm

3. A 12.5 eV electron beam is used to bombard gaseous hydrogen at ground state. The energy level upto which the hydrogen atoms would be excited is

(a) 2 (b) 3 (c) 4 (d) 1

4. Let  $r$ ,  $v$ ,  $E$  be the radius of orbit, speed of electron and total energy of electron respectively in H-atom. Which of the following quantities according to Bohr theory, is proportional to the quantum number  $n$ ?

(a)  $vr$  (b)  $rE$  (c)  $\frac{r}{E}$  (d)  $\frac{r}{v}$

5.



What is the value of current through the diode in the circuit given?

(a) Zero (b) 1 mA  
(c) 19 mA (d) 9 mA

6.

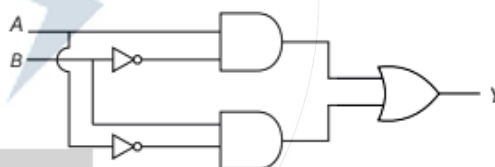

For the given logic circuit, the output  $Y$  for inputs  $(A = 0, B = 1)$  and  $(A = 0, B = 0)$  respectively are

(a) 0, 0 (b) 0, 1  
(c) 1, 0 (d) 1, 1

7. From dimensional analysis, the Rydberg constant can be expressed in terms of electric charge ( $e$ ), mass ( $m$ ) and Planck constant ( $h$ ) as [consider  $\frac{1}{4\pi\epsilon_0} \equiv 1$  unit]

(a)  $\frac{h^2}{me^2}$  (b)  $\frac{me^4}{h^2}$   
(c)  $\frac{m^2e^4}{h^2}$  (d)  $\frac{me^2}{h}$

8.



Three blocks are pushed with a force  $F$  across a frictionless table as shown in figure above. Let  $N_1$  be the contact force between the left two blocks and  $N_2$  be the contact force between the right two blocks. Then,

- (a)  $F > N_1 > N_2$       (b)  $F > N_2 > N_1$   
 (c)  $F > N_1 = N_2$       (d)  $F = N_1 = N_2$

9.

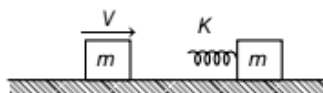

A block of mass  $m$  slides with speed  $v$  on a frictionless table towards another stationary block of mass  $m$ . A massless spring with spring constant  $k$  is attached to the second block as shown in figure. The maximum distance, the spring gets compressed through is

- (a)  $\sqrt{\frac{m}{k}} v$     (b)  $\sqrt{\frac{m}{2k}} v$     (c)  $\sqrt{\frac{k}{m}} v$     (d)  $\sqrt{\frac{k}{2m}} v$

10.

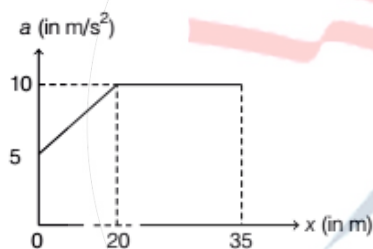

The acceleration *versus* distance graph for a particle moving with initial velocity 5 m/s is shown in the figure. The velocity of the particle at  $x = 35$  m will be

- (a) 20.62 m/s      (b) 20 m/s  
 (c) 25 m/s      (d) 50 m/s

11. A simple pendulum, consisting of a small ball of mass  $m$  attached to a massless string hanging vertically from the ceiling is oscillating with an amplitude such that  $T_{\max} = 2T_{\min}$ , where  $T_{\max}$  and  $T_{\min}$  are the maximum and minimum tension in the string, respectively. The value of maximum tension  $T_{\max}$  in the string is

- (a)  $\frac{3mg}{2}$     (b)  $mg$     (c)  $\frac{3mg}{4}$     (d)  $3mg$

12. In case of projectile motion, which one of the following figures represent variation of horizontal component of velocity ( $u_x$ ) with time  $t$ ? (Assume that air resistance is negligible)

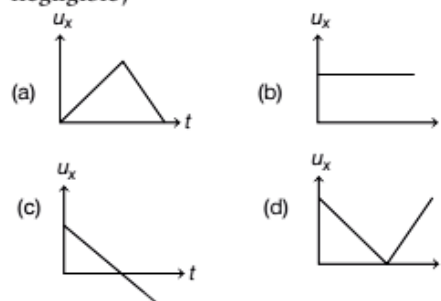

13. A uniform thin rod of length  $L$ , mass  $m$  is lying on a smooth horizontal table. A horizontal impulse  $P$  is suddenly applied perpendicular to the rod at one end. The total energy of the rod after the impulse is

- (a)  $\frac{P^2}{m}$     (b)  $\frac{7P^2}{8m}$     (c)  $\frac{13P^2}{2m}$     (d)  $\frac{2P^2}{m}$

14. Centre of mass (CM) of three particles of masses 1 kg, 2 kg and 3 kg lies at the point (1, 2, 3) and CM of another system of particles of 3 kg and 2 kg lies at the point (-1, 3, -2). Where should we put a particle of mass 5 kg, so that the CM of entire system lies at the CM of the first system?

- (a) (3, 1, 8)      (b) (0, 0, 0)  
 (c) (1, 3, 2)      (d) (-1, 2, 3)

15. A body of density  $12 \times 10^3 \text{ kg/m}^3$  is dropped from rest from a height 1 m into a liquid of density  $2.4 \times 10^3 \text{ kg/m}^3$ . Neglecting all dissipative effects, the maximum depth to which the body sinks before returning to float on the surface is

- (a) 0.1 m    (b) 1 m    (c) 0.01 m    (d) 2 m

16. Two solid spheres  $S_1$  and  $S_2$  of same uniform density fall from rest under gravity in a viscous medium and after sometime, reach terminal velocities  $v_1$  and  $v_2$ , respectively. If ratio of masses  $\frac{m_1}{m_2} = 8$ , then  $\frac{v_1}{v_2}$  will be equal to

- (a) 2    (b) 4    (c)  $\frac{1}{2}$     (d)  $\frac{1}{4}$

17.

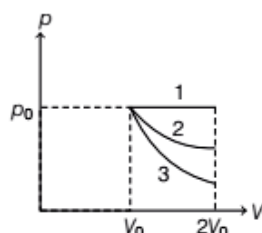

In the given figure, 1 represents isobaric, 2 represents isothermal and 3 represents adiabatic processes of an ideal gas. If  $\Delta U_1$ ,  $\Delta U_2$  and  $\Delta U_3$  be the changes in internal energy in these processes respectively, then

- (a)  $\Delta U_1 < \Delta U_2 < \Delta U_3$  (b)  $\Delta U_1 > \Delta U_3 < \Delta U_2$   
 (c)  $\Delta U_1 = \Delta U_2 > \Delta U_3$  (d)  $\Delta U_1 > \Delta U_2 > \Delta U_3$

18. If pressure of real gas  $O_2$  in a container is given by  $p = \frac{RT}{2V - b} - \frac{a}{4b^2}$ , then the mass of the gas in the container is

- (a) 32 g (b) 16 g  
 (c) 4 g (d) 64 g

19. 300 g of water at  $25^\circ\text{C}$  is added to 100 g of ice at  $0^\circ\text{C}$ . The final temperature of the mixture is

- (a)  $12.5^\circ\text{C}$  (b)  $0^\circ\text{C}$  (c)  $25^\circ\text{C}$  (d)  $50^\circ\text{C}$

20.

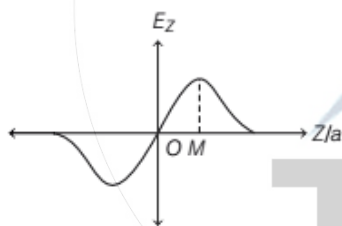

The variation of electric field along the Z-axis due to a uniformly charged circular ring of radius  $a$  in  $XY$ -plane as shown in the figure. The value of coordinate  $M$  will be

- (a)  $\frac{1}{2}$  (b)  $\sqrt{2}$  (c) 1 (d)  $\frac{1}{\sqrt{2}}$

21. A metal sphere of radius  $R$  carrying charge  $q$  is surrounded by a thick concentric metal shell of inner and outer radii  $a$  and  $b$ , respectively. The net charge on the shell is zero. The potential at the centre of the sphere, when the outer surface of the shell is grounded will be

- (a)  $\frac{q}{4\pi\epsilon_0} \left( \frac{1}{a} - \frac{1}{b} \right)$  (b)  $\frac{q}{4\pi\epsilon_0} \frac{1}{a}$   
 (c)  $\frac{q}{4\pi\epsilon_0} \left( \frac{1}{R} - \frac{1}{a} \right)$  (d)  $\frac{q}{4\pi\epsilon_0} \frac{1}{R}$

22. Three infinite plane sheets carrying uniform charge densities  $-\sigma$ ,  $2\sigma$ ,  $4\sigma$  are placed parallel to  $XZ$ -plane at  $Y = a$ ,  $3a$ ,  $4a$ , respectively. The electric field at the point  $(0, 2a, 0)$  is

- (a)  $\frac{5\sigma}{2\epsilon_0} \hat{j}$  (b)  $-\frac{7\sigma}{2\epsilon_0} \hat{j}$   
 (c)  $\frac{\sigma}{2\epsilon_0} \hat{j}$  (d)  $\frac{5\sigma}{-2\epsilon_0} \hat{j}$

23. Two point charges  $+q_1$  and  $+q_2$  are placed a finite distance  $d$  apart. It is desired to put a third charge  $q_3$  in between these two charges, so that  $q_3$  is in equilibrium. This is

- (a) possible only, if  $q_3$  is negative  
 (b) possible only, if  $q_3$  is positive  
 (c) possible irrespective of the sign of  $q_3$   
 (d) Not possible at all

24.

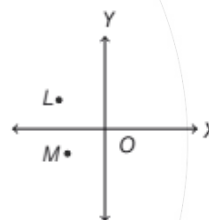

Consider two infinitely long wires parallel to Z-axis carrying same current  $I$  in the positive z-direction. One wire passes through the point  $L$  at coordinates  $(-1, +1)$  and the other wire passes through the point  $M$  at coordinates  $(-1, -1)$ . The resultant magnetic field at the origin  $O$  will be

- (a)  $\frac{\mu_0 I}{2\sqrt{2}\pi} \hat{j}$  (b)  $\frac{\mu_0 I}{2\pi} \hat{j}$   
 (c)  $\frac{\mu_0 I}{2\sqrt{2}\pi} \hat{i}$  (d)  $\frac{\mu_0 I}{4\pi} \hat{i}$

25. A thin charged rod is bent into the shape of a small circle of radius  $R$ , the charge per unit length of the rod being  $\lambda$ . The circle is rotated about its axis with a time period  $T$  and it is found the magnetic field at a distance  $d$  away ( $d \gg R$ ) from the centre and on the axis,

varies as  $R^m/d^n$ . The values of  $m$  and  $n$  respectively are

- (a)  $m = 2, n = 2$  (b)  $m = 2, n = 3$   
(c)  $m = 3, n = 2$  (d)  $m = 3, n = 3$

26.

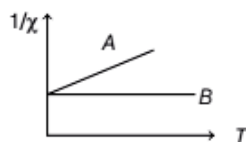

For two types of magnetic materials A and B, variation of  $1/\chi$  ( $\chi$  : susceptibility) versus temperature  $T$  is shown in the figure. Then,

- (a) A is diamagnetic and B is paramagnetic  
(b) A is ferromagnetic and B diamagnetic  
(c) A is paramagnetic and B is ferromagnetic  
(d) A is paramagnetic and B is diamagnetic

27.

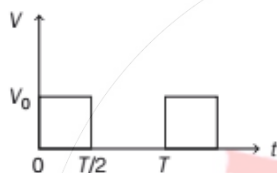

The rms value of potential difference  $V$  shown in the figure is

- (a)  $\frac{V_0}{2}$  (b)  $V_0$  (c)  $\frac{V_0}{\sqrt{3}}$  (d)  $\frac{V_0}{\sqrt{2}}$

28.

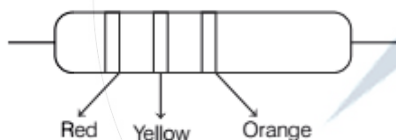

The carbon resistor with colour code is shown in the figure. There is no fourth band in the resistor. The value of the resistance is

- (a)  $24 \text{ M}\Omega \pm 20\%$  (b)  $14 \text{ k}\Omega \pm 5\%$   
(c)  $24 \text{ k}\Omega \pm 20\%$  (d)  $34 \text{ k}\Omega \pm 10\%$

29.

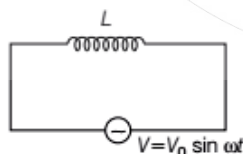

Consider a pure inductive AC circuit as shown in the figure. If the average power consumed is  $P$ , then

- (a)  $P > 0$  (b)  $P < 0$   
(c)  $P = 0$  (d)  $P$  is infinite

30.

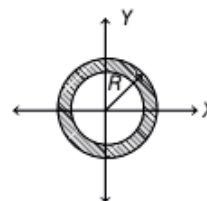

The cross-section of a reflecting surface is represented by the equation  $x^2 + y^2 = R^2$  as shown in the figure. A ray travelling in the positive  $x$ -direction is directed toward positive  $y$ -direction after reflection from the surface at point  $M$ . The coordinate of the point  $M$  on the reflecting surface is

- (a)  $\left(\frac{R}{\sqrt{2}}, \frac{R}{\sqrt{2}}\right)$  (b)  $\left(-\frac{R}{2}, -\frac{R}{2}\right)$   
(c)  $\left(-\frac{R}{\sqrt{2}}, \frac{R}{\sqrt{2}}\right)$  (d)  $\left(\frac{R}{\sqrt{2}}, -\frac{R}{\sqrt{2}}\right)$

### Category-II (Q. 31 to 35)

Carry 2 marks each and only one option is correct. In case of incorrect answer or any combination of more than one answer, 1/2 mark will be deducted.

31. For a plane electromagnetic wave, the electric field is given by

$E = 90 \sin(0.5 \times 10^3 x + 1.5 \times 10^{11} t) \hat{k}$  V/m. The corresponding magnetic field  $B$  will be

- (a)  $B = 3 \times 10^{-7} \sin(0.5 \times 10^3 x + 1.5 \times 10^{11} t) \hat{i}$  T  
(b)  $B = 3 \times 10^{-7} \sin(0.5 \times 10^3 x + 1.5 \times 10^{11} t) \hat{j}$  T  
(c)  $B = 27 \times 10^9 \sin(0.5 \times 10^3 x + 1.5 \times 10^{11} t) \hat{j}$  T  
(d)  $B = 3 \times 10^{-7} \sin(0.5 \times 10^3 x + 1.5 \times 10^{11} t) \hat{k}$  T

32. Two metal wires of identical dimensions are connected in series. If  $\sigma_1$  and  $\sigma_2$  are the electrical conductivities of the metal wires respectively, the effective conductivity of the combination is

- (a)  $\sigma_1 + \sigma_2$  (b)  $\frac{\sigma_1 \sigma_2}{\sigma_1 + \sigma_2}$  (c)  $\frac{2\sigma_1 \sigma_2}{\sigma_1 + \sigma_2}$  (d)  $\frac{\sigma_1 + \sigma_2}{2\sigma_1 \sigma_2}$

33. A uniform rod of length  $L$  pivoted at one end  $P$  is freely rotated in a horizontal plane with an angular velocity  $\omega$  about a vertical axis passing through  $P$ . If the temperature of the system is increased by  $\Delta T$ , angular velocity

becomes  $\frac{\omega}{2}$ . If coefficient of linear expansion

of the rod is  $\alpha$  ( $\alpha \ll 1$ ), then  $\Delta T$  will be

- (a)  $\frac{1}{\alpha}$  (b)  $\frac{1}{2\alpha}$  (c)  $\frac{1}{4\alpha}$  (d)  $\alpha$

34. An ideal gas of molar mass  $M$  is contained in a very tall vertical cylindrical column in the uniform gravitational field. Assuming the gas temperature to be  $T$ , the height at which the centre of gravity of the gas is located is ( $R \rightarrow$  universal gas constant)

- (a)  $\frac{RT}{g}$  (b)  $\frac{RT}{Mg}$   
(c)  $MgR$  (d)  $RTg$

35. Under isothermal conditions, two soap bubbles of radii  $a$  and  $b$  coalesce to form a single bubble of radius  $c$ . If the external pressure is  $p$ , then surface tension of the bubbles is

- (a)  $\frac{p(c^3 - a^3 + b^3)}{4(a^2 + b^2 - c^2)}$  (b)  $\frac{p(c^3 - a^3 - b^3)}{4(a^2 + b^2 - c^2)}$   
(c)  $\frac{p(c^2 + a^3 - b^2)}{4(a^3 + b^3 - c^3)}$  (d)  $\frac{p(a^3 + b^3 - c^3)}{4(a^2 + b^2 - c^2)}$

### Category-III (Q. Nos. 36 to 40)

Carry 2 marks each and one or more option(s) is/are correct. If all correct answers are not marked and also no incorrect answer is marked, then score =  $2 \times$  number of correct answers marked + actual number of correct answers. If any wrong option is marked or if any combination including a wrong option is marked, the answer will be considered wrong, but there is no negative marking for the same and zero marks will be awarded.

36.

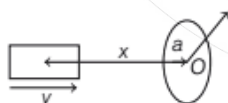

A small bar magnet of dipole moment  $M$  is moving with speed  $v$  along  $x$ -direction towards a small closed circular conducting loop of radius  $a$  with its centre  $O$  at  $x = 0$  (see figure). Assume  $x \gg a$  and the coil has a resistance  $R$ . Then, which of the following statement(s) is/are true?

(a) Magnetic field at the centre  $O$  of the circular coil due to the bar magnet is  $\frac{M}{x^3}$ .

(b) Induced emf is proportional to  $\frac{1}{x^4}$ .

(c) The magnetic moment  $\mu$  due to induced current in the coil is proportional to  $a^4$ .

(d) The heat produced is proportional to  $\frac{1}{x^6}$ .

37. Electric field component of an EM radiation varies with time as  $E = a(\cos \omega_0 t + \sin \omega t \cos \omega_0 t)$ , where  $a$  is a constant and  $\omega = 10^{15} \text{ s}^{-1}$ ,  $\omega_0 = 5 \times 10^{15} \text{ s}^{-1}$ . This radiation falls on a metal whose stopping potential is  $-2 \text{ eV}$ . Then, which of the following statement(s) is/are true? ( $h = 6.62 \times 10^{-34} \text{ J-s}$ )

- (a) For light of frequency  $\omega$ , photoelectric effect is not possible.  
(b) Stopping potential versus frequency graph will be a straight line.  
(c) The work function of the metal is  $-2 \text{ eV}$ .  
(d) The maximum kinetic energy of the photoelectrons is  $-2 \text{ eV}$ .

38.

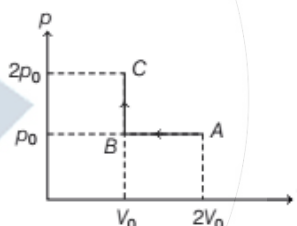

Consider the  $p$ - $V$  diagram for 1 mole of an ideal monatomic gas shown in the figure. Which of the following statement(s) is/are true?

- (a) The change in internal energy for the whole process is zero.  
(b) Heat is rejected during the process.  
(c) Change in internal energy for process  $A \rightarrow B$  is  $-\frac{3}{2} p_0 V_0$ .  
(d) Work done by the gas during the entire process is  $2 p_0 V_0$ .

39. The potential energy of a particle of mass  $0.02 \text{ kg}$  moving along  $X$ -axis is given by  $V = Ax(x - 4) \text{ J}$ , where  $x$  is in metre and  $A$  is a constant. Which of the following statement(s) is/are correct?

- (a) The particle is acted upon by a constant force.  
 (b) The particle executes simple harmonic motion.  
 (c) The speed of the particle is maximum at  $x = 2$  m.  
 (d) The period of oscillation of the particle is  $\frac{\pi}{5}$  s.

40.

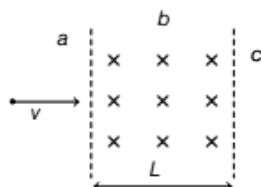

A particle of mass  $m$  and charge  $q$  moving with velocity  $v$  enters region- $b$  from region- $a$  along the normal to the boundary as shown in the figure. Region- $b$  has a uniform magnetic field  $B$  perpendicular to the plane of the paper. Also, region- $b$  has length  $L$ .

Choose the correct statement.

- (a) The particle enters region- $c$  only if  $v > \frac{qLB}{m}$ .  
 (b) The particle enters region- $c$  only if  $v < \frac{qLB}{m}$ .  
 (c) Path of the particle is a circle in region- $b$ .  
 (d) Time spent in region- $b$  is independent of velocity  $v$ .

## Chemistry

### Category-I (Q. Nos. 41 to 70)

Carry 1 mark each and only one option is correct. In case of incorrect answer or any combination of more than one answer, 1/4 mark will be deducted.

41. The exact order of boiling points of the compounds *n*-pentane, isopentane, butanone and 1-butanol is

- (a) *n*-pentane < isopentane < butanone < 1-butanol  
 (b) isopentane < *n*-pentane < butanone < 1-butanol  
 (c) butanone < *n*-pentane < isopentane < 1-butanol  
 (d) 1-butanol < butanone < *n*-pentane < isopentane

42. The maximum number of atoms that can be in one plane in the molecule *p*-nitrobenzonitrile are

- (a) 6 (b) 12  
 (c) 13 (d) 15

43. Cyclo [18] carbon is an allotrope of carbon with molecular formula  $C_{18}$ . It is a ring of 18 carbon atoms, connected by single and triple bonds. The total number of triple bonds present in this cyclocarbon are

- (a) 9 (b) 10  
 (c) 12 (d) 6

44. *p*-nitro-*N,N*-dimethylaniline cannot be represented by the resonating structures.

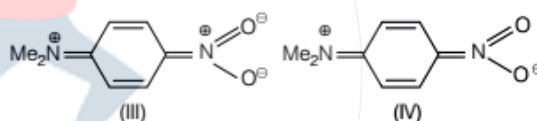
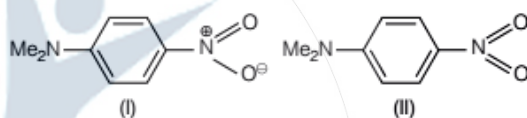

- (a) I and II (b) II and IV  
 (c) I and III (d) III and IV

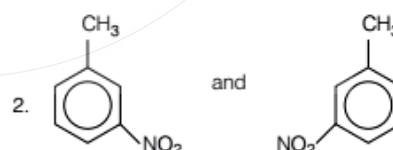
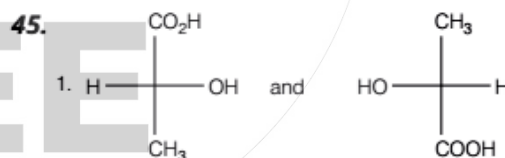

The relationship between the pair of compounds shown above are respectively

- (a) homomer (identical), enantiomer and constitutional isomer  
 (b) enantiomer, enantiomer and diastereomer  
 (c) homomer (identical), homomer (identical) and constitutional isomer  
 (d) enantiomer, homomer (identical) and geometrical isomer

46. The exact order of acidity of the compounds *p*-nitrophenol, acetic acid, acetylene and ethanol is

- (a) *p*-nitrophenol < acetic acid < acetylene < ethanol  
 (b) acetic acid < *p*-nitrophenol < acetylene < ethanol  
 (c) acetylene < *p*-nitrophenol < ethanol < acetic acid  
 (d) acetylene < ethanol < *p*-nitrophenol < acetic acid

47.

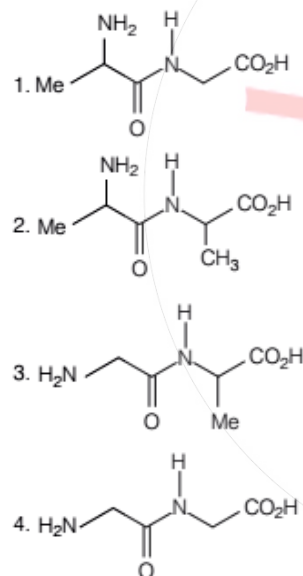

The dipeptides which may be obtained from the amino acids glycine and alanine are

- (a) Only 1 (b) Only 2  
 (c) Both 1 and 2 (d) All of them

48. Benzaldehyde + methanol

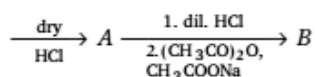

The compounds *A* and *B* above are respectively.

- (a) and
- (b) and
- (c) and
- (d) and

49. For a spontaneous reaction at all temperatures which of the following is correct?

- (a) Both  $\Delta H$  and  $\Delta S$  are positive  
 (b)  $\Delta H$  is positive and  $\Delta S$  is negative  
 (c)  $\Delta H$  is negative and  $\Delta S$  is positive  
 (d) Both  $\Delta H$  and  $\Delta S$  are negative

50. A given amount of  $\text{Fe}^{2+}$  is oxidised by  $x$  mol of  $\text{MnO}_4^-$  in acidic medium. The number of moles of  $\text{Cr}_2\text{O}_7^{2-}$  required to oxidise the same amount of  $\text{Fe}^{2+}$  in acidic medium is

- (a)  $x$  (b)  $0.83x$   
 (c)  $2.0x$  (d)  $1.2x$

51. An element crystallises in a body centered cubic lattice. The edge length of the unit cell is 200 pm and the density of the element is  $5.0 \text{ g cm}^{-3}$ . Calculate the number of atoms in 100 g of this element.

- (a)  $2.5 \times 10^{23}$  (b)  $2.5 \times 10^{24}$   
 (c)  $5.0 \times 10^{23}$  (d)  $5.0 \times 10^{24}$

52. Molecular velocities of two gases at the same temperature ( $T$ ) are  $u_1$  and  $u_2$ . Their masses are  $m_1$  and  $m_2$  respectively. Which of the following expressions is correct at temperature  $T$ ?

- (a)  $\frac{m_1}{u_1^2} = \frac{m_2}{u_2^2}$  (b)  $m\mu_1 = m_2\mu_2$   
 (c)  $\frac{m_1}{u_1} = \frac{m_2}{u_2}$  (d)  $m\mu_1^2 = m_2\mu_2^2$

- 53.** When 20 g of naphthoic acid ( $C_{11}H_8O_2$ ) is dissolved in 50 g of benzene, a freezing point depression of 2K is observed. The van't Hoff factor ( $i$ ) is [ $K_f = 1.72 \text{ K kg mol}^{-1}$ ]
- (a) 0.5    (b) 1.0    (c) 2.0    (d) 3.0
- 54.** The equilibrium constant for the reaction  $N_2(g) + O_2(g) \rightleftharpoons 2NO(g)$  is  $4 \times 10^{-4}$  at 2000 K. In presence of a catalyst the equilibrium is attained 10 times faster. Therefore, the equilibrium constant, in presence of the catalyst at 2000 K is
- (a)  $4 \times 10^{-4}$     (b)  $4 \times 10^{-3}$   
(c)  $4 \times 10^{-5}$     (d)  $2.5 \times 10^{-4}$
- 55.** Under the same reaction conditions, initial concentration of  $1.386 \text{ mol dm}^{-3}$  of a substance becomes half in 40 s and 20 s through first-order and zero-order kinetics respectively. Ratio  $\left(\frac{k_1}{k_0}\right)$  of the rate constants for first-order ( $k_1$ ) and zero-order ( $k_0$ ) of the reactions is
- (a)  $0.5 \text{ mol}^{-1} \text{ dm}^3$     (b)  $0.5 \text{ mol dm}^{-3}$   
(c)  $1.0 \text{ mol dm}^{-3}$     (d)  $2.0 \text{ mol}^{-1} \text{ dm}^3$
- 56.** Which of the following solutions will have highest conductivity?
- (a) 0.1 M  $CH_3COOH$     (b) 0.1 M NaCl  
(c) 0.1 M  $KNO_3$     (d) 0.1 M HCl
- 57.** Indicate the products ( $X$ ) and ( $Y$ ) in the following reactions
- $$Na_2S + nS(n = 1 - 8) \longrightarrow (X)$$
- $$Na_2SO_3 + S \longrightarrow (Y)$$
- |  |  |
|--|--|
| <p>(X)</p> <p>(a) <math>Na_2S_2O_3</math><br/>(b) <math>Na_2S_{(n+1)}</math><br/>(c) <math>Na_2S_n</math><br/>(d) <math>Na_2S_5</math></p> | <p>(Y)</p> <p><math>Na_2S_2</math><br/><math>Na_2S_2O_3</math><br/><math>Na_2S_2O_3</math><br/><math>Na_2S_2O_4</math></p> |
|--|--|
- 58.** 2.5 mL 0.4 M weak monoacidic base ( $K_b = 1 \times 10^{-12}$  at  $25^\circ\text{C}$ ) is titrated with 2/15 M HCl in water at  $25^\circ\text{C}$ . The concentration of  $H^+$  at equivalence point is ( $K_w = 1 \times 10^{-14}$ , at  $25^\circ\text{C}$ )
- (a)  $3.7 \times 10^{-13} \text{ M}$     (b)  $32 \times 10^{-7} \text{ M}$   
(c)  $32 \times 10^{-2} \text{ M}$     (d)  $2.7 \times 10^{-2} \text{ M}$
- 59.** Solubility products ( $K_{sp}$ ) of the salts of types  $MX$ ,  $MX_2$  and  $M_3X$  at temperature  $T$  are  $4.0 \times 10^{-3}$ ,  $3.2 \times 10^{-14}$  and  $2.7 \times 10^{-15}$  respectively. Solubilities (in  $\text{mol dm}^{-3}$ ) of the salts at temperature  $T$  are in the order.
- (a)  $MX > MX_2 > M_3X$     (b)  $M_3X > MX_2 > MX$   
(c)  $MX_2 > M_3X > MX$     (d)  $MX > M_3X > MX_2$
- 60.** The reduction potential of hydrogen half-cell will be negative if
- (a)  $p(H_2) = 1 \text{ atm}$  and  $[H^+] = 1.0 \text{ M}$   
(b)  $p(H_2) = 1 \text{ atm}$  and  $[H^+] = 2.0 \text{ M}$   
(c)  $p(H_2) = 2 \text{ atm}$  and  $[H^+] = 1.0 \text{ M}$   
(d)  $p(H_2) = 2 \text{ atm}$  and  $[H^+] = 2.0 \text{ M}$
- 61.** A saturated solution of  $BaSO_4$  at  $25^\circ\text{C}$  is  $4 \times 10^{-5} \text{ M}$ . The solubility of  $BaSO_4$  in 0.1 M  $Na_2SO_4$  at this temperature will be
- (a)  $1.6 \times 10^{-9} \text{ M}$     (b)  $1.6 \times 10^{-8} \text{ M}$   
(c)  $4 \times 10^{-6} \text{ M}$     (d)  $4 \times 10^{-4} \text{ M}$
- 62.** A solution is made by a concentrated solution of  $Co(NO_3)_2$  with a concentrated solution of  $NaNO_2$  is 50% acetic acid. A solution of a salt containing metal  $M$  is added to the mixture, when a yellow precipitate is formed. Metal ' $M$ ' is
- (a) magnesium    (b) sodium  
(c) potassium    (d) zinc
- 63.** Extraction of a metal ( $M$ ) from its sulphide ore ( $M_2S$ ) involves the following chemical reactions
- $$2M_2S + 3O_2 \xrightarrow{\text{Heat}} 2M_2O + 2SO_2 \uparrow$$
- $$M_2S + 2M_2O \xrightarrow{\text{Heat}} 6M + SO_2 \uparrow$$
- (a) Zn    (b) Cu    (c) Fe    (d) Ca
- 64.** The white precipitate ( $Y$ ), obtained on passing colourless and odourless gas ( $X$ ) through an ammoniacal solution of NaCl, loses about 37% of its weight on heating and a white residue ( $Z$ ) of basic nature is left. Identify ( $X$ ), ( $Y$ ) and ( $Z$ ) from following sets.
- |     |        |                |                |
|-----|--------|----------------|----------------|
|     | (X)    | (Y)            | (Z)            |
| (a) | $N_2$  | $(NH_4)_2CO_3$ | $NH_4Cl$       |
| (b) | $O_2$  | $NaNH_4CO_3$   | $NaHCO_3$      |
| (c) | $CO_2$ | $NH_4HCO_3$    | $(NH_4)_2CO_3$ |
| (d) | $CO_2$ | $NaHCO_3$      | $Na_2CO_3$     |



65. Which structure has delocalised  $\pi$ -electrons?

- (a)  $O_3$  (b) CO  
(c) HCN (d)  $O_3$  and HCN

66. The  $H_3O^+$  ions has the following shape

- (a) tetrahedral (b) pyramidal  
(c) triangular planar (d) "T" shaped

67. For the reaction  $^{14}N(\alpha, p)^{17}O$ , 1.16 MeV (Mass equivalent = 0.00124 amu) of energy is absorbed. Mass on the reactant side is 18.00567 amu and proton mass = 1.00782 amu. The atomic mass of  $^{17}O$  will be

- (a) 17.0044 amu (b) 16.9991 amu  
(c) 17.0114 amu (d) 16.9966 amu

68. A solution of  $NaNO_3$ , when treated with a mixture of Zn dust and 'A' yields ammonia. 'A' can be

- (a) caustic soda  
(b) dilute sulphuric acid  
(c) concentrated sulphuric acid  
(d) sodium carbonate

69. Indicate the number of unpaired electrons in  $K_3[Fe(CN)_6]$  and  $K_4[Fe(CN)_6]$ .

- |     | $K_3[Fe(CN)_6]$ | $K_4[Fe(CN)_6]$ |
|-----|-----------------|-----------------|
| (a) | 1               | 0               |
| (b) | 5               | 6               |
| (c) | 6               | 5               |
| (d) | 0               | 1               |

70. Which of the following compounds have magnetic moment identical with  $[Cr(H_2O)_6]^{3+}$ ?

- (a)  $[Cu(H_2O)_6]^{2+}$  (b)  $[Mn(H_2O)_6]^{3+}$   
(c)  $[Fe(H_2O)_6]^{3+}$  (d)  $[Mn(H_2O)_6]^{3+}$

### Category-II (Q. Nos. 71 to 75)

Carry 2 marks each and only one option is correct. In case of incorrect answer or any combination of more than one answer, 1/2 mark will be deducted.

71. Among the following chlorides the compounds which will be hydrolysed most easily and most slowly in aqueous NaOH solution are respectively:

1. Methoxymethyl chloride
2. Benzyl chloride
3. Neopentyl chloride
4. Propyl chloride

- (a) 1 and 3 (b) 2 and 3  
(c) 2 and 4 (d) 3 and 1

72. The products X and Y which are formed in the following sequence of reactions are respectively.

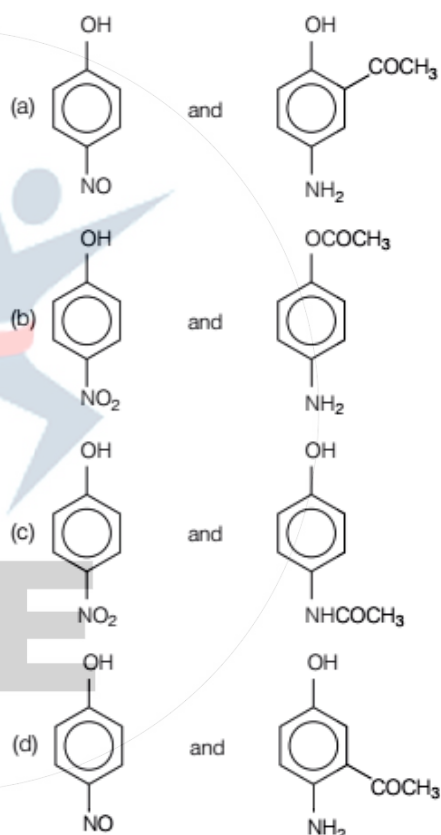
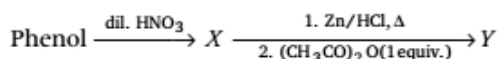

73. The atomic masses of helium and neon are 4.0 and 20.0 amu respectively. The value of the de-Broglie wavelength of helium gas at  $-73^\circ\text{C}$  is M times the de-Broglie wavelength of neon at  $727^\circ\text{C}$ . The value of M is

- (a) 5 (b) 25  
(c)  $\frac{1}{5}$  (d)  $\frac{1}{25}$

74. The mole fraction of a solute in a binary solution is 0.1 at 298 K, molarity of this solution is same as its molality. Density of this solution at 298 K is  $2.0 \text{ g cm}^{-3}$ . The ratio of molecular weights of the solute and the solvent ( $M_{\text{solute}} / M_{\text{solvent}}$ ) is  
 (a) 9 (b)  $\frac{1}{9}$  (c) 4.5 (d)  $\frac{1}{4.5}$

75. 5.75 mg of sodium vapour is converted to sodium ion. If the ionisation energy of sodium is  $490 \text{ kJ mol}^{-1}$  and atomic weight is 23 units, the amount of energy needed for this conversion will be  
 (a) 1.96 kJ (b) 1960 kJ  
 (c) 122.5 kJ (d) 0.1225 kJ

**Category-III** (Q.Nos. 76 to 80)

Carry 2 marks each and one or more option(s) is/are correct. If all correct answers are not marked and no incorrect answer is marked, then score =  $2 \times$  number of correct answers marked + actual number of correct answers. If any wrong option is marked or if any combination including a wrong option is marked, the answer will be considered wrong, but there is no negative marking for the same and zero mark will be awarded.

76. The product(s) in the following sequence of reactions will be

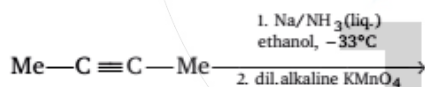

Product(s)

- (a)  $\begin{array}{c} \text{Me} \\ | \\ \text{H}-\text{C}-\text{OH} \\ | \\ \text{H}-\text{C}-\text{OH} \\ | \\ \text{Me} \end{array}$  (b)  $\begin{array}{c} \text{Me} \\ | \\ \text{H}-\text{C}-\text{OH} \\ | \\ \text{HO}-\text{C}-\text{H} \\ | \\ \text{Me} \end{array}$
- (c)  $\begin{array}{c} \text{Me} \\ | \\ \text{HO}-\text{C}-\text{H} \\ | \\ \text{H}-\text{C}-\text{OH} \\ | \\ \text{Me} \end{array}$  (d)  $\begin{array}{c} \text{Me} \\ | \\ \text{HO}-\text{C}-\text{H} \\ | \\ \text{HO}-\text{C}-\text{H} \\ | \\ \text{Me} \end{array}$

77. The compounds X and Y are respectively

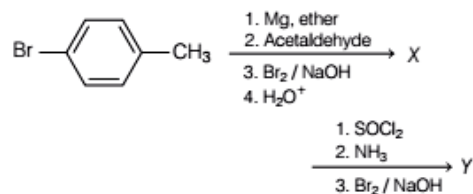

- (a)  $\text{H}_3\text{C}-\text{C}_6\text{H}_4-\text{CH}(\text{OH})\text{CH}_3$  and  $\text{H}_3\text{C}-\text{C}_6\text{H}_4-\text{CH}(\text{NH}_2)\text{CH}_3$   
 (b)  $\text{H}_3\text{C}-\text{C}_6\text{H}_4-\text{C}(=\text{O})\text{CH}_3$  and  $\text{H}_3\text{C}-\text{C}_6\text{H}_4-\text{NH}_2$   
 (c)  $\text{H}_3\text{C}-\text{C}_6\text{H}_4-\text{CH}(\text{OH})\text{CH}_3$  and  $\text{H}_3\text{C}-\text{C}_6\text{H}_4-\text{CONH}_2$   
 (d)  $\text{H}_3\text{C}-\text{C}_6\text{H}_4-\text{CO}_2\text{H}$  and  $\text{H}_3\text{C}-\text{C}_6\text{H}_4-\text{NH}_2$

78. Aqueous solution of  $\text{HNO}_3$ ,  $\text{KOH}$ ,  $\text{CH}_3\text{COOH}$  and  $\text{CH}_3\text{COONa}$  of identical concentration are provided. The pair(s) of solutions which form a buffer upon mixing is (are)

- (a)  $\text{HNO}_3$  and  $\text{CH}_3\text{COOH}$   
 (b)  $\text{KOH}$  and  $\text{CH}_3\text{COONa}$   
 (c)  $\text{HNO}_3$  and  $\text{CH}_3\text{COONa}$   
 (d)  $\text{CH}_3\text{COOH}$  and  $\text{CH}_3\text{COONa}$

79. Reaction of silver nitrate solution with phosphorus acid produces

- (a) silver phosphite  
 (b) phosphoric acid  
 (c) metallic silver  
 (d) silver phosphate

80.  $\text{N}_2\text{H}_4$  and  $\text{H}_2\text{O}_2$  show similarity in

- (a) density  
 (b) reducing nature  
 (c) oxidising nature  
 (d) hybridisation of central atoms

## Mathematics

### Category-I (Q. Nos. 1 to 30)

Carry 1 marks each and only one option is correct. In case of incorrect answer or any combination of more than one answer, 1/4 mark will be deducted.

1. If  $I = \lim_{x \rightarrow 0} \sin \left( \frac{e^x - x - 1 - \frac{x^2}{2}}{x^2} \right)$ , then limit

- (a) does not exist  
 (b) exists and equals 1  
 (c) exists and equals 0  
 (d) exists and equals  $\frac{1}{2}$

2. Let  $f : R \rightarrow R$  be such that  $f(0) = 0$  and

$|f'(x)| \leq 5$  for all  $x$ . Then  $f(1)$  is in

- (a) (5, 6) (b) [-5, 5]  
 (c)  $(-\infty, -5) \cup (5, \infty)$  (d) [-4, 4]

3. If  $\int \frac{\sin 2x}{(a + b \cos x)^2} dx$

$$= \alpha \left[ \log_e |a + b \cos x| + \frac{a}{a + b \cos x} \right] + c,$$

then  $\alpha$  is equal to

- (a)  $\frac{2}{b^2}$  (b)  $\frac{2}{a^2}$   
 (c)  $-\frac{2}{b^2}$  (d)  $-\frac{2}{a^2}$

4. Let  $g(x) = \int_x^{2x} \frac{f(t)}{t} dt$  where  $x > 0$  and  $f$  be

continuous function and  $f(2x) = f(x)$ , then

- (a)  $g(x)$  is strictly increasing function  
 (b)  $g(x)$  is strictly decreasing function  
 (c)  $g(x)$  is constant function  
 (d)  $g(x)$  is not derivable function

5.  $\int_1^3 \frac{|x-1|}{|x-2| + |x-3|} dx$  is equal to

- (a)  $1 + \frac{4}{3} \log_e 3$  (b)  $1 + \frac{3}{4} \log_e 3$   
 (c)  $1 - \frac{4}{3} \log_e 3$  (d)  $1 - \frac{3}{4} \log_e 3$

6. The value of the integral

$$\int_{-\frac{1}{2}}^{\frac{1}{2}} \left\{ \left( \frac{x+1}{x-1} \right)^2 + \left( \frac{x-1}{x+1} \right)^2 - 2 \right\}^{\frac{1}{2}} dx$$
 is equal to

- (a)  $\log_e \left( \frac{4}{3} \right)$  (b)  $4 \log_e \left( \frac{3}{4} \right)$   
 (c)  $4 \log_e \left( \frac{4}{3} \right)$  (d)  $\log_e \left( \frac{3}{4} \right)$

7. If  $\int_{\log_e 2}^x (e^x - 1)^{-1} dx = \log_e \frac{3}{2}$  then the value of  $x$

is

- (a) 1 (b)  $e^2$  (c)  $\log 4$  (d)  $\frac{1}{e}$

8. The normal to a curve at  $P(x, y)$  meets the  $X$ -axis at  $G$ . If the distance of  $G$  from the origin is twice the abscissa of  $P$  then the curve is

- (a) a parabola (b) a circle  
 (c) a hyperbola (d) an ellipse

9. The differential equation of all the ellipses centred at the origin and have axes as the co-ordinate axes is

- (a)  $y^2 + xy^2 - yy' = 0$   
 (b)  $xyy'' + xy'^2 - yy' = 0$   
 (c)  $yy' + xy'^2 - xy' = 0$   
 (d)  $x^2y' + xy'' - 3y = 0$

where  $y' \equiv \frac{dy}{dx}$ ,  $y'' \equiv \frac{d^2y}{dx^2}$

10. If  $x \frac{dy}{dx} + y = \frac{xf(xy)}{f'(xy)}$ , then  $|f(xy)|$  is equal to

- (a)  $ke^{x^2/2}$  (b)  $ke^{y^2/2}$   
 (c)  $ke^{x^2}$  (d)  $ke^{y^2}$

11. The straight line through the origin which divides the area formed by the curves  $y = 2x - x^2$ ,  $y = 0$  and  $x = 1$  into two equal halves is

- (a)  $y = x$  (b)  $y = 2x$   
 (c)  $y = \frac{3}{2}x$  (d)  $y = \frac{2}{3}x$

12. The value of  $\int_0^5 \max\{x^2, 6x - 8\} dx$  is  
 (a) 72 (b) 125  
 (c) 43 (d) 69
13. A bulb is placed at the centre of a circular track of radius 10 m. A vertical wall is erected touching the track at a point  $P$ . A man is running along the track with a speed of 10 m/sec. Starting from  $P$  the speed with which his shadow is running along the wall when he is at an angular distance of  $60^\circ$  from  $P$  is  
 (a) 30 m/sec (b) 40 m/sec  
 (c) 60 m/sec (d) 80 m/sec
14. Two particles  $A$  and  $B$  move from rest along a straight line with constant accelerations  $f$  and  $f'$  respectively. If  $A$  takes  $m$  sec. more than that of  $B$  and describes  $n$  units more than that of  $B$  in acquiring the same velocity, then  
 (a)  $(f + f')m^2 = ff'n$  (b)  $(f - f')m^2 = ff'n$   
 (c)  $(f' - f)n = \frac{1}{2}ff'm^2$  (d)  $\frac{1}{2}(f + f')m = ff'n^2$
15. Let  $\alpha, \beta, \gamma$  be three non-zero vectors which are pairwise non-collinear. If  $\alpha + 3\beta$  is collinear with  $\gamma$  and  $\beta + 2\gamma$  is collinear with  $\alpha$ , then  $\alpha + 3\beta + 6\gamma$  is  
 (a)  $\gamma$  (b) 0  
 (c)  $\alpha + \gamma$  (d)  $\alpha$
16. Let  $f: R \rightarrow R$  be given by  $f(x) = |x^2 - 1|, x \in R$ . Then  
 (a)  $f$  has a local minimum at  $x = \pm 1$  but no local maximum.  
 (b)  $f$  has a local minimum at  $x = 0$  but no local maximum.  
 (c)  $f$  has a local minima at  $x = \pm 1$  and a local maxima at  $x = 0$ .  
 (d)  $f$  has neither a local maxima nor a local minima at any point.
17. Let  $a, b, c$  be real numbers, each greater than 1, such that  $\frac{2}{3} \log_b a + \frac{3}{5} \log_c b + \frac{5}{2} \log_a c = 3$ . If the value of  $b$  is 9, then the value of ' $a$ ' must be  
 (a)  $\sqrt[3]{81}$  (b)  $\frac{27}{2}$  (c) 18 (d) 27
18. Consider the real valued function  $h: \{0, 1, 2, \dots, 100\} \rightarrow R$  such that  $h(0) = 5, h(100) = 20$  and satisfying  $h(p) = \frac{1}{2} \{h(p+1) + h(p-1)\}$  for every  $p = 1, 2, \dots, 99$ . Then the value of  $h(1)$  is  
 (a) 5.15 (b) 5.5  
 (c) 6 (d) 6.15
19. If  $|z| = 1$  and  $z \neq \pm 1$ , then all the points representing  $\frac{z}{1-z^2}$  lie on  
 (a) a line not passing through the origin  
 (b) the line  $y = x$   
 (c) the  $X$ -axis  
 (d) the  $Y$ -axis
20. Let  $C$  denote the set of all complex numbers. Define  $A = \{(z, w) \mid z, w \in C \text{ and } |z| = |w|\}$ ,  $B = \{(z, w) \mid z, w \in C \text{ and } z^2 = w^2\}$ . Then  
 (a)  $A = B$  (b)  $A \subset B$   
 (c)  $B \subset A$  (d)  $A \cap B = \phi$
21. Let  $\alpha, \beta$  be the roots of the equation  $x^2 - 6x - 2 = 0$  with  $\alpha > \beta$ . If  $a_n = \alpha^n - \beta^n$  for  $n \geq 1$ , then the value of  $\frac{a_{10} - 2a_8}{2a_6}$  is  
 (a) 1 (b) 2  
 (c) 3 (d) 4
22. For  $x \in R, x \neq -1$ , if  $(1+x)^{2016} + x(1+x)^{2015} + x^2(1+x)^{2014} + \dots + x^{2016} = \sum_{i=0}^{2016} a_i \cdot x^i$ , then  $a_{17}$  is equal to  
 (a)  $\frac{2016!}{17!1999!}$  (b)  $\frac{2016!}{16!}$   
 (c)  $\frac{2017!}{2000!}$  (d)  $\frac{2017!}{17!2000!}$
23. Five letter words, having distinct letters, are to be constructed using the letters of the word 'EQUATION' so that each word contains exactly three vowels and two consonants. How many of them have all the vowels together?  
 (a) 3600 (b) 1800  
 (c) 1080 (d) 900

- 24.** What is the number of ways in which an examiner can assign 10 marks to 4 questions, giving not less than 2 marks to any question?  
 (a) 4 (b) 6  
 (c) 10 (d) 16
- 25.** The digit in the unit's place of the number  $1! + 2! + 3! + \dots + 99!$  is  
 (a) 3 (b) 0  
 (c) 1 (d) 7
- 26.** If  $M$  is a  $3 \times 3$  matrix such that  $(0, 1, 2)$   
 $M = (1 \ 0 \ 0)$ ,  $(3, 4 \ 5)$   $M = (0, 1, 0)$ , then  
 $(6 \ 7 \ 8)$   $M$  is equal to  
 (a)  $(2 \ 1 \ -2)$  (b)  $(0 \ 0 \ 1)$   
 (c)  $(-1 \ 2 \ 0)$  (d)  $(9 \ 10 \ 8)$
- 27.** Let  $A = \begin{pmatrix} 1 & 0 & 0 \\ 0 & \cos t & \sin t \\ 0 & -\sin t & \cos t \end{pmatrix}$   
 Let  $\lambda_1, \lambda_2, \lambda_3$  be the roots of  $\det(A - \lambda I_3) = 0$ , where  $I_3$  denotes the identity matrix. If  $\lambda_1 + \lambda_2 + \lambda_3 = \sqrt{2} + 1$ , then the set of possible values of  $t$ ,  $-\pi \leq t < \pi$  is  
 (a) a void set (b)  $\left\{\frac{\pi}{4}\right\}$   
 (c)  $\left\{-\frac{\pi}{4}, \frac{\pi}{4}\right\}$  (d)  $\left\{-\frac{\pi}{3}, \frac{\pi}{3}\right\}$
- 28.** Let  $A$  and  $B$  two non singular skew symmetric matrices such that  $AB = BA$ , then  $A^2 B^2 (A^T B)^{-1} (AB^{-1})^T$  is equal to  
 (a)  $A^2$  (b)  $-B^2$   
 (c)  $-A^2$  (d)  $AB$
- 29.** If  $a_n (> 0)$  be the  $n^{\text{th}}$  term of a G.P. then  
 $\begin{vmatrix} \log a_n & \log a_{n+1} & \log a_{n+2} \\ \log a_{n+3} & \log a_{n+4} & \log a_{n+5} \\ \log a_{n+6} & \log a_{n+7} & \log a_{n+8} \end{vmatrix}$  is equal to  
 (a) 1 (b) 2 (c) -2 (d) 0
- 30.** Let  $A, B, C$  be three non-void subsets of set  $S$ . Let  $(A \cap C) \cup (B \cap C') = \phi$  where  $C'$  denote the complement of set  $C$  in  $S$ . Then  
 (a)  $A \cap B = \phi$  (b)  $A \cap B \neq \phi$   
 (c)  $A \cap C = A$  (d)  $A \cup C = A$
- 31.** Let  $T$  and  $U$  be the set of all orthogonal matrices of order 3 over  $R$  and the set of all non-singular matrices of order 3 over  $R$  respectively. Let  $A = \{-1, 0, 1\}$ , then  
 (a) there exists bijective mapping between  $A$  and  $T, U$ .  
 (b) there does not exist bijective mapping between  $A$  and  $T, U$ .  
 (c) there exists bijective mapping between  $A$  and  $T$  but not between  $A$  and  $U$ .  
 (d) there exists bijective mapping between  $A$  and  $U$  but not between  $A$  and  $T$ .
- 32.** Four persons  $A, B, C$  and  $D$  throw an unbiased die, turn by turn, in succession till one gets an even number and win the game. What is the probability that  $A$  wins the game if  $A$  begins?  
 (a)  $\frac{1}{4}$  (b)  $\frac{1}{2}$  (c)  $\frac{7}{15}$  (d)  $\frac{8}{15}$
- 33.** The mean and variance of a binomial distribution are 4 and 2 respectively. Then the probability of exactly two successes is  
 (a)  $\frac{7}{64}$  (b)  $\frac{21}{128}$  (c)  $\frac{7}{32}$  (d)  $\frac{9}{32}$
- 34.** Let  $S_n = \cot^{-1} 2 + \cot^{-1} 8 + \cot^{-1} 18 + \cot^{-1} 32 + \dots$  to  $n^{\text{th}}$  term. Then  $\lim_{n \rightarrow \infty} S_n$  is  
 (a)  $\frac{\pi}{3}$  (b)  $\frac{\pi}{4}$  (c)  $\frac{\pi}{6}$  (d)  $\frac{\pi}{8}$
- 35.** If  $a > 0, b > 0$  then the maximum area of the parallelogram whose three vertices are  $O(0, 0)$ ,  $A(a \cos \theta, b \sin \theta)$  and  $B(a \cos \theta, -b \sin \theta)$  is  
 (a)  $ab$  when  $\theta = \frac{\pi}{4}$  (b)  $3ab$  when  $\theta = \frac{\pi}{4}$   
 (c)  $ab$  when  $\theta = -\frac{\pi}{2}$  (d)  $2ab$
- 36.** Let  $A$  be the fixed point  $(0, 4)$  and  $B$  be a moving point on  $X$ -axis. Let  $M$  be the midpoint of  $AB$  and let the perpendicular bisector of  $AB$  meet the  $Y$ -axis at  $R$ . The locus of the midpoint  $P$  of  $MR$  is  
 (a)  $y + x^2 = 2$  (b)  $x^2 + (y - 2)^2 = \frac{1}{4}$   
 (c)  $(y - 2)^2 - x^2 = \frac{1}{4}$  (d)  $x^2 + y^2 = 16$

37. A moving line intersects the lines  $x + y = 0$  and  $x - y = 0$  at the points  $A, B$  respectively such that the area of the triangle with vertices  $(0, 0)$ ,  $A$  and  $B$  has a constant area  $C$ . The locus of the mid-point  $AB$  is given by the equation
- (a)  $(x^2 + y^2)^2 = C^2$  (b)  $(x^2 - y^2)^2 = C^2$   
 (c)  $(x + y)^2 = C^2$  (d)  $(x - y)^2 = C^2$
38. The locus of the vertices of the family of parabolas  $6y = 2a^3x^2 + 3a^2x - 12a$  is
- (a)  $xy = \frac{105}{64}$  (b)  $xy = \frac{64}{105}$   
 (c)  $xy = \frac{35}{16}$  (d)  $xy = \frac{16}{35}$
39. A ray of light along  $x + \sqrt{3}y = \sqrt{3}$  gets reflected upon reaching  $X$ -axis, the equation of the reflected ray is
- (a)  $y = x + \sqrt{3}$  (b)  $\sqrt{3}y = x - \sqrt{3}$   
 (c)  $y = \sqrt{3}x - \sqrt{3}$  (d)  $\sqrt{3}y = x - 1$
40. Two tangents to the circle  $x^2 + y^2 = 4$  at the points  $A$  and  $B$  meet at  $M(-4, 0)$ . The area of the quadrilateral  $MAOB$ , where  $O$  is the origin is
- (a)  $4\sqrt{3}$  sq units (b)  $2\sqrt{3}$  sq units  
 (c)  $\sqrt{3}$  sq units (d)  $3\sqrt{3}$  sq units
41. From a point  $(d, 0)$  three normals are drawn to the parabola  $y^2 = x$ , then
- (a)  $d = \frac{1}{2}$  (b)  $d > \frac{1}{2}$   
 (c)  $d < \frac{1}{2}$  (d)  $d = \frac{1}{3}$
42. If from a point  $P(a, b, c)$ , perpendicular  $PA$  and  $PB$  are drawn to  $YZ$  and  $ZX$ -planes respectively, then the equation of the plane  $OAB$  is
- (a)  $bcx + cay + abz = 0$  (b)  $bcx + cay - abz = 0$   
 (c)  $bcx - cay + abz = 0$  (d)  $bcx - cay - abz = 0$
43. The co-ordinate of a point on the auxiliary circle of the ellipse  $x^2 + 2y^2 = 4$  corresponding to the point on the ellipse whose eccentric angle is  $60^\circ$  will be
- (a)  $(\sqrt{3}, 1)$  (b)  $(1, \sqrt{3})$   
 (c)  $(1, 1)$  (d)  $(1, 2)$
44. The locus of the centre of a variable circle which always touches two given circles externally is
- (a) an ellipse (b) a hyperbola  
 (c) a parabola (d) a circle
45. A line with positive direction cosines passes through the point  $P(2, -1, 2)$  and makes equal angle with co-ordinate axes. The line meets the plane  $2x + y + z = 9$  at point  $Q$ . The length of the line segment  $PQ$  equals.
- (a) 1 unit (b)  $\sqrt{2}$  unit  
 (c)  $\sqrt{3}$  unit (d) 2 unit
46. For  $y = \sin^{-1} \left\{ \frac{5x + 12\sqrt{1-x^2}}{13} \right\}; |x| \leq 1$ , if  $a(1-x^2)y_2 + bxy_1 = 0$  then  $(a, b) =$
- (a)  $(2, 1)$  (b)  $(1, -1)$   
 (c)  $(-1, 1)$  (d)  $(1, 2)$
47.  $f(x)$  is real valued function such that  $2f(x) + 3f(-x) = 15 - 4x$  for all  $x \in R$ . Then  $f(2) =$
- (a)  $-15$  (b)  $22$  (c)  $11$  (d)  $0$
48. Consider the functions  $f_1(x) = x$ ,  $f_2(x) = 2 + \log_e x$ ,  $x > 0$ . The graphs of the functions intersect
- (a) once in  $(0, 1)$  but never in  $(1, \infty)$   
 (b) once in  $(0, 1)$  and once in  $(e^2, \infty)$   
 (c) once in  $(0, 1)$  and once in  $(e, e^2)$   
 (d) more than twice in  $(0, \infty)$
49. The equation  $6^x + 8^x = 10^x$  has
- (a) no real root.  
 (b) infinitely many rational roots  
 (c) exactly one real root  
 (d) two distinct real roots
50. Let  $f : D \rightarrow R$  where  $D = [-0, 1] \cup [2, 4]$  be defined by
- $$f(x) = \begin{cases} x, & \text{if } x \in [0, 1] \\ 4 - x, & \text{if } x \in [2, 4] \end{cases}$$
- Then,
- (a) Rolle's theorem is applicable to  $f$  in  $D$ .  
 (b) Rolle's theorem is not applicable to  $f$  in  $D$ .  
 (c) there exists  $\xi \in D$  for which  $f'(\xi) = 0$  but Rolle's theorem is not applicable.  
 (d)  $f$  is not continuous in  $D$ .

**Category-II** (Q.Nos. 51 to 65)

Carry 2 marks each and only one option is correct. In case of incorrect answer or any combination of more than one answer, 1/2 mark will be deducted.

- 51.** Let  $f(x)$  be continuous periodic function with period  $T$ . Let  $I = \int_a^{a+T} f(x) dx$ . Then
- (a)  $I$  is linear function in 'a'  
 (b)  $I$  does not depend on 'a'  
 (c)  $0 < I < a^2 + 1$  where  $I$  depends on 'a'  
 (d)  $I$  is quadratic function in 'a'
- 52.** If  $b = \int_0^1 \frac{e^t}{t+1} dt$ , then  $\int_{a-1}^a \frac{e^{-t}}{t-a-1} dt$  is
- (a)  $be^a$       (b)  $be^{-a}$       (c)  $-be^{-a}$       (d)  $-be^a$
- 53.** The differential of  $f(x) = \log_e(1 + e^{10x}) - \tan^{-1}(e^{5x})$  at  $x = 0$  and for  $dx = 0.2$  is
- (a) 0.5      (b) 0.3      (c) -0.2      (d) -0.5
- 54.** Given that  $f : S \rightarrow R$  is said to have a fixed point at  $c$  of  $S$  if  $f(c) = c$ .  
 Let  $f : [1, \infty) \rightarrow R$  be defined by  $f(x) = 1 + \sqrt{x}$ .  
 Then
- (a)  $f$  has no fixed point in  $[1, \infty)$   
 (b)  $f$  has unique fixed point in  $[1, \infty)$   
 (c)  $f$  has to fixed points in  $[1, \infty)$   
 (d)  $f$  has infinitely many fixed points in  $[1, \infty)$
- 55.** The  $\lim_{x \rightarrow \infty} \left( \frac{3x-1}{3x+1} \right)^{4x}$  equals
- (a) 1      (b) 0      (c)  $e^{-8/3}$       (d)  $e^{-4/9}$
- 56.** The area bounded by the parabolas  $y = 4x^2$ ,  $y = \frac{x^2}{9}$  and the straight line  $y = 2$  is
- (a)  $\frac{20\sqrt{2}}{3}$  sq. unit      (b)  $10\sqrt{5}$  sq. unit  
 (c)  $\frac{10\sqrt{3}}{7}$  sq. unit      (d)  $10\sqrt{2}$  sq. unit
- 57.** If  $a(\alpha \times \beta) + b\beta \times \gamma + c(\gamma \times \alpha) = 0$ , where  $a, b, c$  are non-zero scalars, then the vectors  $\alpha, \beta, \gamma$  are
- (a) parallel      (b) non-coplanar  
 (c) coplanar      (d) mutually perpendicular
- 58.** If the tangent at the point  $P$  with co-ordinates  $(h, k)$  on the curve  $y^2 = 2x^3$  is perpendicular to the straight line  $4x = 3y$ , then
- (a)  $(h, k) = (0, 0)$  only  
 (b)  $(h, k) = \left(\frac{1}{8}, -\frac{1}{16}\right)$  only  
 (c)  $(h, k) = (0, 0)$  or  $\left(\frac{1}{8}, \frac{1}{16}\right)$   
 (d) no such point  $P$  exists
- 59.** The co-efficient of  $a^3b^4c^5$  in the expansion of  $(bc + ca + ab)^6$  is
- (a)  $\frac{12!}{3!4!5!}$       (b)  $\frac{6!}{3!}$   
 (c) 33      (d)  $3 \left( \frac{6!}{3!3!} \right)$
- 60.** Three unequal positive numbers  $a, b, c$  are such that  $a, b, c$  are in G.P. while  $\log\left(\frac{5c}{2a}\right), \log\left(\frac{7b}{5c}\right), \log\left(\frac{2a}{7b}\right)$  are in A.P. Then  $a, b, c$  are the lengths of the sides of
- (a) an isosceles triangle  
 (b) an equilateral triangle  
 (c) a scalene triangle  
 (d) a right-angled triangle
- 61.** The determinant  $\begin{vmatrix} a^2 + 10 & ab & ac \\ ab & b^2 + 10 & bc \\ ac & bc & c^2 + 10 \end{vmatrix}$  is
- (a) divisible by 10 but not by 100  
 (b) divisible by 100  
 (c) not divisible by 100  
 (d) not divisible by 10
- 62.** Let  $R$  be the real line. Let the relations  $S$  and  $T$  or  $R$  be defined by  $S = \{(x, y) : y = x + 1, 0 < x < 2\}$ ,  $T = \{(x, y) : x - y \text{ is an integer}\}$ . Then
- (a) both  $S$  and  $T$  are equivalence relations on  $R$   
 (b)  $T$  is an equivalence on  $R$  but  $S$  is not  
 (c) neither  $S$  nor  $T$  is an equivalence relation on  $R$   
 (d)  $S$  is an equivalence relation on  $R$  but  $T$  is not
- 63.** The plane  $\ell x + my = 0$  is rotated about its line of intersection with the plane  $z = 0$  through an angle  $\alpha$ . The equation changes to

- (a)  $lx + my \pm \tan \alpha \sqrt{\ell^2 + m^2} = 0$   
 (b)  $lx + my \pm z \tan \alpha \sqrt{\ell^2 + m^2 + 1} = 0$   
 (c)  $lx + my \pm z \tan \alpha \sqrt{\ell^2 + 1} = 0$   
 (d)  $lx + my \pm z \tan \alpha \sqrt{\ell^2 + m^2} = 0$

64. The points of intersection of two ellipses  
 $x^2 + 2y^2 - 6x - 12y + 20 = 0$  and  
 $2x^2 + y^2 - 10x - 6y + 15 = 0$  lie on a circle.

The centre of the circle is

- (a) (8, 3) (b) (8, 1)  
 (c)  $\left(\frac{8}{3}, 3\right)$  (d) (3, 8)

65. Let  $I = \int_{\frac{\pi}{4}}^{\frac{\pi}{3}} \frac{\sin x}{x} dx$ . Then

- (a)  $\frac{\sqrt{3}}{8} \leq I \leq \frac{\sqrt{2}}{6}$  (b)  $\frac{\sqrt{3}}{2\pi} \leq I \leq \frac{2\sqrt{3}}{\pi}$   
 (c)  $\frac{\sqrt{3}}{9} \leq I \leq \frac{\sqrt{2}}{16}$  (d)  $\pi \leq I \leq \frac{4\pi}{3}$

### Category-III (Q. Nos. 66 to 75)

Carry 2 marks each and one or more option(s) is/are correct. If all correct answers are not marked and also no incorrect answer is marked, then score = 2 × number of correct answers marked + actual number of correct answers. If any wrong option is marked or if any combination including a wrong option is marked, the answer will be considered wrong, but there is no negative marking for the same and zero marks will be awarded.

66. If  $|z + i| - |z - 1| = |z| - 2 = 0$  for a complex number  $z$ , then  $z$  is equal to

- (a)  $\sqrt{2}(1 + i)$  (b)  $\sqrt{2}(1 - i)$   
 (c)  $\sqrt{2}(-1 + i)$  (d)  $\sqrt{2}(-1 - i)$

67.  $\begin{vmatrix} x & 3x+2 & 2x-1 \\ 2x-1 & 4x & 3x+1 \\ 7x-2 & 17x+6 & 12x-1 \end{vmatrix} = 0$  is true for

- (a) only one value of  $x$   
 (b) only two value of  $x$   
 (c) only three values of  $x$   
 (d) infinitely many value of  $x$

68. The remainder when  $7^{7^{7^{\dots 7}}}$  (22 time 7) is divided by 48 is

- (a) 21 (b) 7  
 (c) 47 (d) 1

69. Whichever of the following is/are correct?

- (a) To evaluate  $I_1 = \int_{-2}^2 \frac{dx}{4+x^2}$ , it is possible to put  $x = \frac{1}{t}$   
 (b) To evaluate  $I_2 = \int_0^1 \sqrt{x^2+1} dx$ , it is possible to put  $x = \sec t$   
 (c) To evaluate  $I_2 = \int_0^1 \sqrt{x^2+1} dx$ , it is not possible to put  $x = \operatorname{cosec} \theta$   
 (d) To evaluate  $I_1$ , it is not possible to put  $x = \frac{1}{t}$

70. A plane meets the co-ordinate axes at the points  $A, B, C$  respectively such a way that the centroid of  $\Delta ABC$  is  $(1, r, r^2)$  for some real  $r$ . If the plane passes through the point  $(5, 5, -12)$  then  $r =$

- (a)  $\frac{3}{2}$  (b) 4  
 (c) -4 (d)  $-\frac{3}{2}$

71. Let  $P$  be a variable point on a circle  $C$  and  $Q$  be a fixed point outside  $C$ . If  $R$  is the midpoint of the line segment  $PQ$ , then locus of  $R$  is

- (a) a circle  
 (b) a circle and a pair of straight lines  
 (c) a rectangular hyperbola  
 (d) a pair of straight lines

72.  $\lim_{n \rightarrow \infty} \left\{ \frac{\sqrt{n}}{\sqrt{(n^3)}} + \frac{\sqrt{n}}{\sqrt{(n+4)^3}} + \frac{\sqrt{n}}{\sqrt{(n+8)^3}} + \dots + \frac{\sqrt{n}}{\sqrt{[n+4(n-1)]^3}} \right\}$  is

- (a)  $\frac{5-\sqrt{5}}{10}$  (b)  $\frac{5+\sqrt{5}}{10}$   
 (c)  $\frac{2+\sqrt{3}}{2}$  (d)  $\frac{2-\sqrt{3}}{2}$



73. Let  $f(x) = \begin{cases} 0, & \text{if } -1 \leq x < 0 \\ 1, & \text{if } x = 0 \\ 2, & \text{if } 0 < x \leq 1 \end{cases}$  and let

$$F(x) = \int_{-1}^x f(t) dt, \quad -1 \leq x \leq 1, \text{ then}$$

- (a)  $F$  is continuous function in  $[-1, 1]$   
 (b)  $F$  is discontinuous function in  $[-1, 1]$   
 (c)  $F'(x)$  exists at  $x = 0$   
 (d)  $F'(x)$  does not exist at  $x = 0$

74. The greatest and least value of

$$f(x) = \tan^{-1} x - \frac{1}{2} \ln x \text{ on } \left[ \frac{1}{\sqrt{3}}, \sqrt{3} \right] \text{ are}$$

- (a)  $f_{\min} = \sqrt{3} - 1$   
 (b)  $f_{\max} = \frac{\pi}{6} + \frac{1}{4} \ln 3$   
 (c)  $f_{\min} = \frac{\pi}{3} - \frac{1}{4} \ln 3$   
 (d)  $f_{\max} = \frac{\pi}{12} + \ln 5$

75. Let  $f$  and  $g$  be periodic functions with the periods  $T_1$  and  $T_2$  respectively. Then  $f + g$  is

- (a) periodic with period  $T_1 + T_2$   
 (b) non-periodic  
 (c) periodic with the period  $T_1$   
 (d) periodic when  $T_1 = T_2$

## Answers

### Physics

1. (d)	2. (c)	3. (c)	4. (a)	5. (a)	6. (c)	7. (*)	8. (a)	9. (a)	10. (c)
11. (a)	12. (b)	13. (d)	14. (a)	15. (b)	16. (b)	17. (d)	18. (b)	19. (b)	20. (d)
21. (a)	22. (b)	23. (c)	24. (b)	25. (d)	26. (d)	27. (d)	28. (c)	29. (c)	30. (c)
31. (b)	32. (c)	33. (b)	34. (b)	35. (b)	36. (b,c)	37. (a,b)	38. (b,c)	39. (b,c)	40. (a,d)

### Chemistry

41. (b)	42. (d)	43. (a)	44. (b)	45. (c)	46. (d)	47. (d)	48. (d)	49. (c)	50. (b)
51. (d)	52. (d)	53. (a)	54. (a)	55. (a)	56. (d)	57. (b)	58. (d)	59. (d)	60. (c)
61. (d)	62. (c)	63. (b)	64. (d)	65. (a)	66. (b)	67. (b)	68. (a)	69. (a)	70. (d)
71. (a)	72. (c)	73. (a)	74. (a)	75. (d)	76. (b,c)	77. (d)	78. (c, d)	79. (b, c)	80. (b,c,d)

### Mathematics

1. (c)	2. (b)	3. (c)	4. (c)	5. (b)	6. (c)	7. (c)	8. (c)	9. (b)	10. (a)
11. (d)	12. (c)	13. (b)	14. (d)	15. (b)	16. (c)	17. (d)	18. (a)	19. (d)	20. (c)
21. (c)	22. (d)	23. (c)	24. (c)	25. (a)	26. (c)	27. (c)	28. (c)	29. (d)	30. (a)
31. (b)	32. (d)	33. (a)	34. (b)	35. (a)	36. (a)	37. (b)	38. (a)	39. (b)	40. (a)
41. (b)	42. (b)	43. (b)	44. (b)	45. (c)	46. (b)	47. (c)	48. (c)	49. (c)	50. (b)
51. (b)	52. (c)	53. (a)	54. (b)	55. (c)	56. (a)	57. (c)	58. (b)	59. (d)	60. (c)
61. (b)	62. (b)	63. (d)	64. (c)	65. (a)	66. (b, c)	67. (d)	68. (b)	69. (c,d)	70. (a,c)
71. (a)	72. (a)	73. (a, d)	74. (b, c)	75. (d)					

(\*) None of the option is correct.

## Answer with Explanations

### Physics

1. (d) The situation is as shown in the figure below

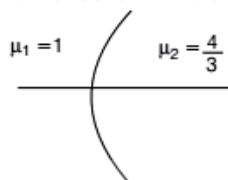

Given,

$$P = 5D$$

$$\therefore f = \frac{1}{P} = \frac{1}{5} \text{m} = 20 \text{ cm}$$

Let  $u = -\infty$  (object distance)

Then,  $v = f$  (by sign convention)

Using formula for refraction at spherical surface,

$$\frac{\mu_2}{v} - \frac{\mu_1}{u} = \frac{\mu_2 - \mu_1}{R}$$

$$\Rightarrow \frac{4}{3 \times (20)} - \frac{1}{(-\infty)} = \frac{4 - 1}{R} \quad [\because v = 20 \text{ cm}]$$

$$\Rightarrow \frac{1}{15} = \frac{1}{3R}$$

$$\Rightarrow R = 5 \text{ cm}$$

2. (c) Given,  $D = 1.2 \text{ m}$ ,  $d = 0.02 \text{ cm} = 0.02 \times 10^{-2} \text{ m}$

According to question,

$$\frac{3D\lambda}{d} - \frac{5D\lambda}{2d} = 0.18 \times 10^{-2}$$

$$\lambda \left[ \frac{3 \times 1.2}{0.02 \times 10^{-2}} - \frac{5 \times 1.2}{2 \times 0.02 \times 10^{-2}} \right] = 0.18 \times 10^{-2}$$

$$\Rightarrow \lambda \left[ 3 - \frac{5}{2} \right] \times 1.2 = 0.18 \times 10^{-2} \times 0.02 \times 10^{-2}$$

$$\Rightarrow \lambda = \frac{0.18 \times 10^{-4} \times 0.02 \times 2}{1.2} \text{ m}$$

$$\Rightarrow \lambda = 0.006 \times 10^{-4} \text{ m}$$

$$\Rightarrow \lambda = 600 \times 10^{-9} \text{ m} \\ = 600 \text{ nm}$$

3. (c) Let initially the electron in hydrogen atom be in ground state, i.e.  $n_1 = 1$  and after bombarding, it jumps to  $n$ th energy level i.e.  $n_2 = n$ , then

$$12.5 \text{ eV} = \left[ \frac{136}{(1)^2} - \frac{136}{n^2} \right] \text{ eV}$$

$$\Rightarrow 1 - \frac{1}{n^2} = \frac{12.5}{136}$$

$$\Rightarrow 1 - \frac{125}{136} = \frac{1}{n^2}$$

$$\Rightarrow \frac{1}{n^2} = 0.080$$

$$\Rightarrow n = 353 \approx 4$$

So,  $n_2 = n = 4$  th excited state.

4. (a) Radius ( $r$ ) of  $n$ th orbit in H-atom =  $\frac{n^2}{Z} \times 0.529 \text{ \AA}$

Speed ( $v$ ) of electron in  $n$ th orbit in H-atom

$$= 2.19 \times 10^6 \left( \frac{Z}{n} \right) \text{ m/s}$$

Energy ( $E$ ) of electron in  $n$ th orbit in H-atom

$$= \frac{-13.6}{n^2} \text{ eV}$$

So, the quantity which is proportional to quantum number  $n$  is  $v$ .

5. (a) The net voltage in the circuit is  $(10 - 9) \text{ V} = 1 \text{ V}$

This leads to reverse bias of diode in the circuit. Hence, current through the diode will equal to  $0 \text{ mA}$ .

6. (c) The given logic circuit is

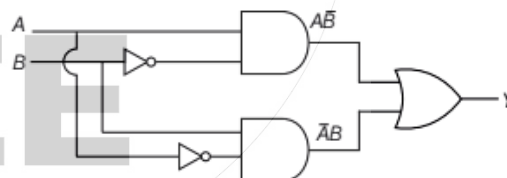

Output is written as

$$Y = A\bar{B} + \bar{A}B$$

When  $A = 0, B = 1$ ,

$$\text{then } Y = 0 \cdot \bar{1} + \bar{0} \cdot 1$$

$$= 0 \cdot 0 + 1 \cdot 1$$

$$= 0 + 1$$

$$= 1$$

When  $A = 0, B = 0$ ,

$$\text{then } Y = 0 \cdot \bar{0} + \bar{0} \cdot 0$$

$$= 0 \cdot 1 + 1 \cdot 0$$

$$= 0 + 0 = 0$$

7. (\*) According to question, from dimensional analysis,

$$R \propto e^a m^b h^c$$

$$\Rightarrow R = ke^a m^b h^c$$

Using dimensional formula of  $R$ ,  $e$ ,  $m$  and  $h$ ,

$$[M^0 L^{-1} T^0] = [M^{1/2} L^{3/2} T^{-1}]^a [M]^b [ML^2 T^{-1}]^c$$

{ Since,  $F = \frac{1}{4\pi\epsilon_0} \cdot \frac{e^2}{r^2} = \frac{e^2}{r^2}$

$$\Rightarrow e^2 = Fr^2$$

$$[e] = [Fr^2]^{1/2} = [MLT^{-2} \cdot L^2]^{1/2} = [M^{1/2} L^{3/2} T^{-1}]$$

$$\Rightarrow [M^0 L^{-1} T^0] = [M^{a/2} L^{3a/2} T^{-a}] [M^b] [M^c L^{2c} T^{-c}]$$

$$\Rightarrow [M^0 L^{-1} T^0] = [M^{a/2+b+c} L^{3a/2+2c} T^{-a-c}]$$

$$\therefore \frac{a}{2} + b + c = 0 \quad \dots(i)$$

$$\frac{3a}{2} + 2c = -1 \quad \dots(ii)$$

$$-a - c = 0 \quad \dots(iii)$$

On solving Eqs. (i), (ii) and (iii), we get

$$a = 2, b = 1, c = -2$$

$$\therefore R \propto e^2 m h^{-2}$$

$$\Rightarrow R \propto \frac{e^2 m}{h^2}$$

Hence, no option is correct.

8. (a) Given,

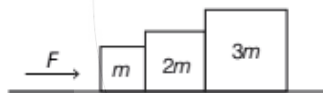

Since, the table is frictionless, hence acceleration of the whole system is given as

$$a = \frac{F}{m + 2m + 3m} = \frac{F}{6m}$$

Free body diagram at 1st block (left most)

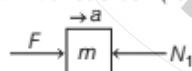

From Newton's equation of motion,

$$F - N_1 = ma = m \times \frac{F}{6m} \quad \left( \because a = \frac{F}{6m} \right)$$

$$\Rightarrow N_1 = \frac{5F}{6}$$

Free body diagram of 3rd block (right most)

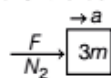

From Newton's equation of motion,

$$N_2 = 3ma = 3m \times \frac{F}{6m} \quad \left( \because a = \frac{F}{6m} \right)$$

$$\Rightarrow N_2 = \frac{F}{2}$$

Hence,  $F > N_1 > N_2$ .

9. (a) At maximum compression of spring, total kinetic energy of first block = potential energy of spring

$$\Rightarrow \frac{1}{2} mv^2 = \frac{1}{2} kx^2$$

$$\Rightarrow x = \sqrt{\frac{m}{k}} \cdot v$$

10. (c) During first half of the motion (i.e. upto  $x = 20$  m) acceleration in increasing linearly is given by

$$a = \frac{5}{20}x + 5 \Rightarrow a = \frac{x}{4} + 5$$

$$\Rightarrow \frac{dv}{dt} = \frac{x}{4} + 5 \quad \left( \because a = \frac{dv}{dt} \right)$$

$$\Rightarrow \frac{v \cdot dv}{dx} = \frac{x}{4} + 5 \quad \left( \because \frac{dx}{dt} = v \Rightarrow dt = \frac{dx}{v} \right)$$

$$\Rightarrow \int_0^v v \cdot dv = \int_0^{20} \left( \frac{x}{4} + 5 \right) \cdot dx$$

$$\Rightarrow \left[ \frac{v^2}{2} \right]_0^v = \left[ \frac{x^2}{8} + 5x \right]_0^{20}$$

$$\Rightarrow \frac{v^2}{2} - \frac{25}{2} = \frac{400}{8} + 100$$

$$\Rightarrow \frac{v^2}{2} = 150 + \frac{25}{2} \Rightarrow v^2 = 325$$

Now, in second half of motion, acceleration is constant, i.e.  $a = 10 \text{ m/s}^2$

$$\Rightarrow v^2 - u^2 = 2as$$

$$\Rightarrow v'^2 - v^2 = 2as \quad (\text{take, } v = v', u = v)$$

$$\Rightarrow v'^2 - 325 = 2 \times 10 \times (35 - 20) \quad (\because v^2 = 325)$$

$$\Rightarrow v' = \sqrt{625} = 25 \text{ m/s}$$

11. (a) The given situation is shown below

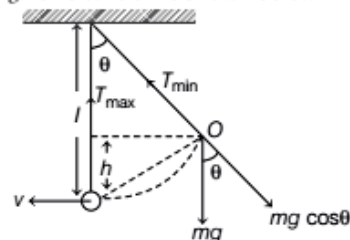

$$T_{\min} = mg \cos \theta \quad \dots (i)$$

$$T_{\max} - mg = \frac{mv^2}{l} \quad \dots (ii)$$

By law of conservation of energy,

$$mgh = \frac{1}{2}mv^2$$

$$\Rightarrow mg(l - l \cos \theta) = \frac{1}{2}mv^2 \quad [\because h = l - l \cos \theta]$$

$$2mg(l - l \cos \theta) = mv^2$$

$$\Rightarrow 2mgl(1 - \cos \theta) = mv^2 \quad \dots (iii)$$

From Eqs. (ii) and (iii), we get

$$T_{\max} - mg = \frac{2mgl(1 - \cos \theta)}{l}$$

$$\Rightarrow T_{\max} - mg = 2mg(1 - \cos \theta)$$

$$\Rightarrow 2T_{\min} - mg = 2mg(1 - \cos \theta) \quad [\because T_{\max} = 2T_{\min}]$$

$$\Rightarrow 2mg \cos \theta - mg = 2mg(1 - \cos \theta) \quad [\text{from Eq. (i)}]$$

$$\Rightarrow 2 \cos \theta - 1 = 2(1 - \cos \theta)$$

$$\Rightarrow 2 \cos \theta - 1 = 2 - 2 \cos \theta$$

$$\Rightarrow 4 \cos \theta = 3$$

$$\Rightarrow \cos \theta = \frac{3}{4}$$

$$\therefore T_{\max} = 2T_{\min} = 2mg \cos \theta = 2mg \times \frac{3}{4} = \frac{3}{2}mg$$

$$\Rightarrow T_{\max} = \frac{3}{2}mg$$

12. (b) In projectile motion, horizontal component at velocity remains constant with time.

Hence, correct representation of graph between  $t$  and  $u_x$  is shown in option (b).



The given impulse acts as both linear and an angular impulse.

Linear impulse =  $P = mv_{\text{CM}}$  (where,  $v_{\text{CM}}$  = velocity of centre at mass of rod)

$$\text{Angular impulse} = P \times \frac{L}{2} = I_{\text{CM}} \omega$$

$$\text{where, } I_{\text{CM}} = \frac{mL^2}{12}$$

and  $\omega$  is angular velocity at rod about centre of mass,

$$\text{i.e. } \omega = \frac{PL}{2I_{\text{CM}}}$$

Kinetic energy

$$= \left[ \frac{1}{2}mv_{\text{CM}}^2 + \frac{1}{2}I_{\text{CM}}\omega^2 \right]$$

$$= \left[ \frac{1}{2} \times m \times \left( \frac{P}{m} \right)^2 + \frac{1}{2} \times \frac{mL^2}{12} \times \frac{P^2 L^2 \times 144}{4 \times m^2 \times L^4} \right]$$

$$= \frac{P^2}{2m} [1 + 3]$$

$$= \frac{2P^2}{m}$$

14. (a) Centre of mass of three particles ( i.e. 1kg, 2kg and 3kg)

$$\frac{1\mathbf{r}_1 + 2\mathbf{r}_2 + 3\mathbf{r}_3}{6} = [1\hat{i} + 2\hat{j} + 3\hat{k}]$$

$$\left[ \because \text{CM} = \frac{m_1\mathbf{r}_1 + m_2\mathbf{r}_2 + m_3\mathbf{r}_3}{m_1 + m_2 + m_3} \right]$$

where,  $\mathbf{r}_1, \mathbf{r}_2$  and  $\mathbf{r}_3$  are position vector of mass 1kg, 2kg and 3kg, respectively.

Now, centre of mass of two particles ( i.e. 3kg and 2kg)

$$\frac{3\mathbf{r}_4 + 2\mathbf{r}_5}{5} = [-\hat{i} + 3\hat{j} - 2\hat{k}]$$

where,  $\mathbf{r}_4$  and  $\mathbf{r}_5$  are position vector of mass 1 kg and 2 kg.

Now, according to question, if 5kg mass is added to whole particle system, then entire mass lies on CM of first system,

$$\frac{1\mathbf{r}_1 + 2\mathbf{r}_2 + 3\mathbf{r}_3 + 3\mathbf{r}_4 + 2\mathbf{r}_5 + 5\mathbf{r}_6}{16} = [1\hat{i} + 2\hat{j} + 3\hat{k}]$$

where,  $\mathbf{r}_6$  is position vector of 5 kg mass.

$$\Rightarrow 6\hat{i} + 12\hat{j} + 18\hat{k} - 5\hat{i} + 15\hat{j} - 10\hat{k} + 5\mathbf{r}_6 = 16\hat{i} + 32\hat{j} + 48\hat{k}$$

$$\Rightarrow 5\mathbf{r}_6 = 15\hat{i} + 5\hat{j} + 40\hat{k}$$

$$\Rightarrow \mathbf{r}_6 = 3\hat{i} + \hat{j} + 8\hat{k}$$

Hence, position of 5 kg mass is (3, 1, 8).

15. (b) Given, density of body =  $1.2 \times 10^3 \text{ kg / m}^3 = \rho_b$

$$\text{Density of liquid} = 2.4 \times 10^3 \text{ kg / m}^3 = \rho_l$$

$$\text{Height of fall} = 1 \text{ m} = H$$

Let the volume of the body be  $V$ .

Then, buoyant force acting on the body when it is totally immersed in liquid =  $(\rho_l V g)$

$$\text{Weight at the body} = (\rho_b V g)$$

$$\text{Net upward force acting on the body} = (\rho_l - \rho_b) V g$$

Net deceleration produced

$$(a) = \frac{\text{Net upward force}}{\text{Mass of body}}$$

$$(a) = \frac{(\rho_l - \rho_b)Vg}{\rho_b V}$$

$$(a) = \frac{(\rho_l - \rho_b)g}{\rho_b}$$

Let initial velocity of the body be  $u$ , then

$$\frac{1}{2}(\rho_b V)u^2 = \rho_b VgH$$

$$\Rightarrow u^2 = 2gH$$

Final velocity of the body will be zero.

$$\Rightarrow v^2 - u^2 = 2as$$

$$\Rightarrow (0)^2 - 2gH = -2 \frac{(\rho_l - \rho_b)g}{\rho_b} \times s$$

$$\Rightarrow s = \frac{\rho_b}{\rho_l - \rho_b} \cdot H = \left( \frac{1.2 \times 10^3}{2.4 \times 10^3 - 1.2 \times 10^3} \right) \cdot 1$$

$$= \frac{1.2}{1.2} = 1 \text{ m}$$

16. (b) Given densities of both spheres are same. Let it be  $\rho$  unit and density of liquid be  $\sigma$  and  $\eta$  be its viscosity.

Let radius of sphere  $S_1$  be  $r_1$  and that of sphere  $S_2$  be  $r_2$  and volumes are  $V_1$  and  $V_2$ , respectively.

Now,

$$\frac{m_1}{V_1} = \frac{m_2}{V_2} \quad (\because \text{density is same})$$

$$\Rightarrow \frac{m_1}{\frac{4}{3}\pi r_1^3} = \frac{m_2}{\frac{4}{3}\pi r_2^3}$$

$$\Rightarrow \left( \frac{r_1}{r_2} \right)^3 = \left( \frac{m_1}{m_2} \right) = \frac{8}{1}$$

$$\Rightarrow \frac{r_1}{r_2} = \frac{2}{1}$$

Now, terminal velocity is given by

$$v = \frac{2r^2(\rho - \sigma)g}{9\eta}$$

$$\Rightarrow \frac{v_1}{v_2} = \frac{\frac{2r_1^2(\rho - \sigma)g}{9\eta}}{\frac{2r_2^2(\rho - \sigma)g}{9\eta}}$$

$$\Rightarrow \frac{v_1}{v_2} = \left( \frac{r_1}{r_2} \right)^2 = 2^2 = 4$$

17. (d) Given figure is

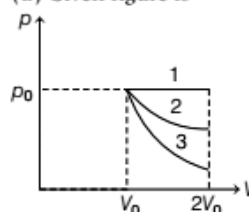

Process 1 is isobaric expansion ( $p = \text{constant}$ ). Hence, temperature of gas will increase, therefore  $\Delta U_1$  will be positive.

Process 2 is an isothermal process,  $\Delta U_2 = 0$

Process 3 is an adiabatic expansion, hence temperature of gas will fall.

$\therefore \Delta U_3 = \text{negative}$

Therefore,  $\Delta U_1 > \Delta U_2 > \Delta U_3$

18. (b) The van der Waals' equation for real gas is as follows

$$p + \frac{an^2}{V^2}(V - nb) = nRT$$

where,  $p$  is the pressure,  $a$  and  $b$  are constants,  $V$  is the volume,  $T$  is the temperature and  $n$  is the number of moles.

van der Waals' equation can be rearranged as

$$p = \frac{nRT}{V - nb} - \frac{an^2}{V^2}$$

Dividing first part with  $n$  and the 2nd part with  $n^2$ , we get

$$p = \frac{\frac{nRT}{n}}{V - nb} - \frac{\frac{an^2}{n^2}}{V^2}$$

$$\Rightarrow p = \frac{RT}{V - b} - \frac{a}{V^2} \quad \dots(i)$$

The equation given in question is as follows

$$p = \frac{RT}{2V - b} - \frac{a}{4b^2} \quad \dots(ii)$$

By comparing Eqs. (i) and (ii), we get

$$\frac{V}{n} = 2V$$

$$\Rightarrow n = \frac{V}{2V} = \frac{1}{2} \quad (\text{i.e. } n = \frac{1}{2} \text{ mole})$$

By using mole formula to determine the amount of  $O_2$  as follows

$$\text{Mole} = \frac{\text{Mass}}{\text{Molar mass}} \quad \dots(iii)$$

The molar mass of O<sub>2</sub> is 32g/mol. Substituting in Eq. (iii), we get

$$\Rightarrow \frac{1}{2} = \frac{\text{Mass}}{32 \text{ g/mol}}$$

$$\Rightarrow \text{Mass of O}_2 = 16 \text{ g}$$

19. (b) We know that, latent heat of fusion at ice is 79.7 cal per gram.

Let final temperature be  $T$ .

Then,

$$m_1 s \Delta T = m_2 L$$

$$\Rightarrow 300 \times 1 \times (25 - T) = 100 \times 75$$

$$\Rightarrow 25 - T = 25$$

$$\Rightarrow T = 0^\circ\text{C}$$

After that total energy left,  $Q = 4.7 \times 100 = 470 \text{ cal}$

Total mass of water = 400 g

Amount of water again converted into ice,

$$m = \frac{Q}{L_{\text{ice}}} = \frac{470}{79.7}$$

$$\Rightarrow m = 5.9 \text{ g}$$

Thus, whole mass is converted into water at 0°C and about 5.9 g water is again converted into ice whose temperature is also 0°C.

After achieving the temperature of 0°C, latent heat of fusion is required firstly for conversion of water into ice, then further lowering of temperature as possible.

So, the final temperature will be 0°C.

20. (d) The electric field along Z-axis due to uniformly charged circular ring of radius  $a$  in XY-plane is given by

$$E = \frac{kqz}{(z^2 + a^2)^{3/2}}$$

where,  $q$  is the net charge on the ring and  $z$  is axial distance on Z - axis from the centre of the ring.

Now, at point M in the graph shown, electric field is maximum.

So,

$$\frac{dE}{dz} = \frac{kq(z^2 + a^2)^{3/2} - \frac{3}{2}(z^2 + a^2)^{1/2} \cdot 2z^2}{(z^2 + a^2)^3}$$

For maxima,  $\frac{dE}{dz} = 0$

$$\Rightarrow (z^2 + a^2)^{3/2} = \frac{3}{2} \times 2z^2(z^2 + a^2)^{1/2}$$

$$\Rightarrow z^2 + a^2 = 3z^2 \Rightarrow 2z^2 = a^2$$

$$\Rightarrow \frac{z}{a} = \frac{1}{\sqrt{2}}$$

21. (a) The given situation is shown below

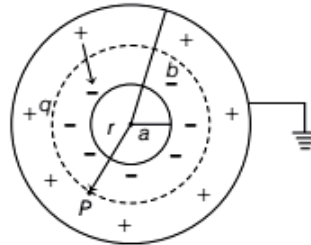

A radial electric field  $E$  exists in the region between the two shells due to charge on inner shell only.

Electric field at point  $P$  is calculated according to Gauss's law,

$$\text{i.e. } \phi_E = E \cdot 4\pi r^2 = \frac{q}{\epsilon_0}$$

$$\Rightarrow E = \frac{q}{4\pi\epsilon_0 r^2} \quad \dots(i)$$

The potential at the centre of sphere,

$$V = -\int_a^b E \cdot dr = \int_a^b E \cdot dr = \int_a^b \frac{q}{4\pi\epsilon_0 r^2} dr$$

[from Eq. (i)]

$$\Rightarrow V = \frac{q}{4\pi\epsilon_0} \left( \frac{1}{a} - \frac{1}{b} \right)$$

22. (b) The given situation is shown in the figure

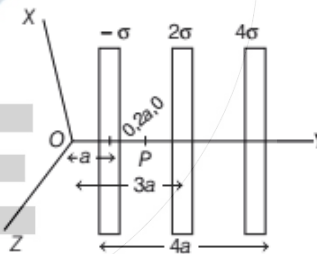

We have to calculate electric field at point  $P(0, 2a, 0)$ .

Net electric field at point  $P$ ,

$$E = \frac{-\sigma}{2\epsilon_0} \hat{j} - \frac{2\sigma}{2\epsilon_0} \hat{j} - \frac{4\sigma}{2\epsilon_0} \hat{j}$$

$$E = \frac{-7\sigma}{2\epsilon_0} \hat{j}$$

23. (c) The given situation is shown below

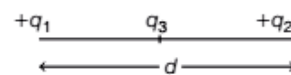

**Case 1** If charge  $q_3$  is taken as positives.

In this situation, force on charge  $q_3$  due to charges  $q_1$  and  $q_2$  will be repulsive and in opposite direction. Hence, at a certain location between  $+q_1$  and  $+q_2$ , charge  $q_3$  will be in equilibrium, when both repulsive forces will be equal in magnitude.

**Case 2** If charge  $q_3$  is taken as negative.

In this situation, force on charge  $q_3$  due to charges  $q_1$  and  $q_2$  will be attractive and in opposite direction. Hence, at a certain location between  $+q_1$  and  $+q_2$ , charge  $q_3$  will be in equilibrium, when both attractive forces will be equal in magnitude.

24. (b) The given situation is shown below

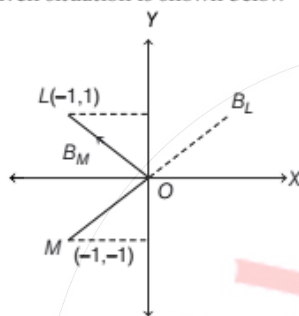

Length,  $OL = \sqrt{1^2 + (-1)^2} = \sqrt{2}$

and  $OM = \sqrt{(-1)^2 + (-1)^2} = \sqrt{2}$

$\therefore$  Magnetic field at point  $O$  due to wire  $L$ ,

$$B_L = \frac{\mu_0}{2\pi} \cdot \frac{I}{\sqrt{2}} \left( \frac{\hat{i} + \hat{j}}{\sqrt{2}} \right) \quad \left[ \because B = \frac{\mu_0}{2\pi} \cdot \frac{I}{r} \right]$$

Magnetic field at point  $O$  due to wire  $M$ ,

$$B_M = \frac{\mu_0}{2\pi} \cdot \frac{I}{\sqrt{2}} \left( \frac{-\hat{i} + \hat{j}}{\sqrt{2}} \right)$$

$\therefore$  Resultant magnetic field at the origin  $O$ ,

$$\begin{aligned} B &= B_L + B_M \\ &= \frac{\mu_0 I}{2\pi\sqrt{2}} \left( \frac{\hat{i} + \hat{j}}{\sqrt{2}} \right) + \frac{\mu_0}{2\pi} \cdot \frac{I}{\sqrt{2}} \left( \frac{-\hat{i} + \hat{j}}{\sqrt{2}} \right) \\ &= \frac{\mu_0 I}{2\sqrt{2}\pi} \left[ \frac{\hat{i} + \hat{j} - \hat{i} + \hat{j}}{\sqrt{2}} \right] \\ &= \frac{\mu_0 I}{2\sqrt{2}} \cdot (\sqrt{2}\hat{j}) = \frac{\mu_0 I}{2\pi} \hat{j} \end{aligned}$$

25. (d) Charge per unit length of the thin rod =  $\lambda$

If  $l$  be the length of the rod, the charge on the rod,

$$q = l\lambda \quad \dots(i)$$

According to given situation,

$$l = 2\pi R$$

$\therefore$  From Eq. (i), we get

$$q = 2\pi R\lambda$$

Current associated,

$$I = \frac{q}{T}$$

$$I = \frac{2\pi R\lambda}{T} \quad \dots(ii)$$

Magnetic field on the axis at a distance  $d$  away from the centre,

$$B = \frac{\mu_0 IR^2}{2(R^2 + d^2)^{3/2}}$$

For  $d \gg R$ ,

$$\begin{aligned} B &= \frac{\mu_0 IR^2}{2(d^2)^{3/2}} \\ &= \frac{\mu_0 IR^2}{2d^3} \\ &= \frac{\mu_0 \left( \frac{2\pi R\lambda}{T} \right) R^2}{2d^3} \\ &= \frac{\mu_0 \pi \lambda}{T} \cdot \frac{R^3}{d^3} \\ B &\propto \frac{R^3}{d^3} \quad \text{[given, } B \propto \frac{R^m}{d^n}] \end{aligned}$$

$$m = 3, n = 3$$

26. (d) Since, susceptibility  $\chi$  of diamagnetic material is independent of temperature.

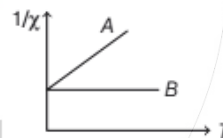

Hence,  $\frac{1}{\chi}$  is also independent of temperature.

Therefore, material  $B$  is diamagnetic. For paramagnetic substance, susceptibility varies inversely as temperature.

i.e.  $\chi \propto \frac{1}{T}$  or  $\frac{1}{\chi} \propto T$

Therefore, material  $A$  is paramagnetic.

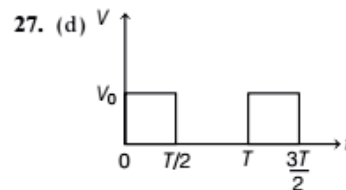

Rms value of potential difference is given as

$$V_{rms} = \sqrt{\frac{V_0^2 + 0^2}{2}}$$

$$= \frac{V_0}{\sqrt{2}}$$

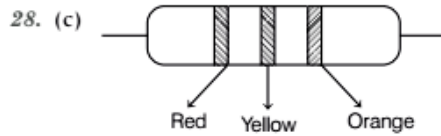

The colours of the four bands of carbon resistors are red, yellow, orange and no fourth band.

∴ Red	Yellow	Orange	No colour
↓	↓	↓	↓
2	4	3	20%
∴ $R = 24 \times 10^3 \Omega \pm 20\%$			
$= 24k\Omega \pm 20\%$			

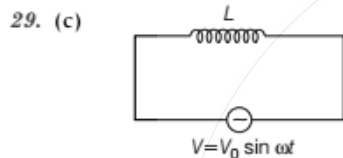

In pure inductive circuit, alternating voltage leads  $\frac{\pi}{2}$  angle from alternating current.

i.e. Phase difference,  $\phi = \frac{\pi}{2}$

Average power consumed,

$$P = V_{rms} \times I_{rms} \times \cos \frac{\pi}{2}$$

$$\Rightarrow P = 0 \quad \left[ \because \cos \frac{\pi}{2} = 0 \right]$$

30. (c) The given situation is shown below

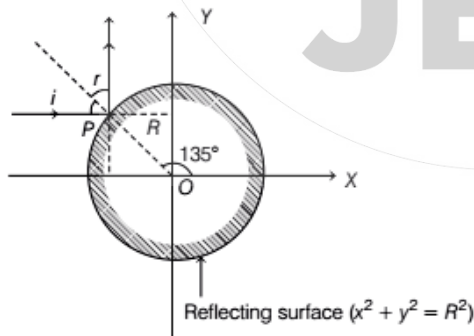

Here,  $i = r$   
 Since,  $i + r = 90^\circ$   
 $\Rightarrow i + i = 90^\circ$   
 $\Rightarrow i = 45^\circ$   
 $i = r = 45^\circ$

Coordinate at point P is  $(R \cos \theta, R \sin \theta) = (R \cos 135^\circ, R \sin 135^\circ)$

$$= \left[ R \left( \frac{-1}{\sqrt{2}} \right), R \left( \frac{1}{\sqrt{2}} \right) \right]$$

$$= \left( \frac{-R}{\sqrt{2}}, \frac{R}{\sqrt{2}} \right)$$

31. (b) For a plane electromagnetic wave, the electric field is given by

$$\mathbf{E} = 90 \sin(0.5 \times 10^3 x + 1.5 \times 10^{11} t) \hat{\mathbf{k}} \text{ V/m}$$

Here,  $E_0 = 90 \text{ V/m}$   
 $\therefore B_0 = \frac{E_0}{c}$   
 $= \frac{90}{3 \times 10^8}$   
 $= 30 \times 10^{-8} \text{ T}$   
 $= 3 \times 10^{-7} \text{ T}$

Since, electric field vector and magnetic field vector, both are perpendicular to each other and also perpendicular to direction of propagation of electromagnetic wave. Hence,

$$B = B_0 \sin(0.5 \times 10^3 x + 1.5 \times 10^{11} t) \hat{\mathbf{j}} \text{ T}$$

$$B = 3 \times 10^{-7} \sin(0.5 \times 10^3 x + 1.5 \times 10^{11} t) \hat{\mathbf{j}} \text{ T}$$

32. (c) Since, both wires are identical, so they have same cross-section  $A$  and same length  $l$ . Also, in series combination of wires, effective resistance,

$$R = R_1 + R_2$$

$$\Rightarrow \frac{(l + l)}{\sigma_{eff} A} = \frac{l}{\sigma_1 A} + \frac{l}{\sigma_2 A}$$

$$\Rightarrow \frac{2}{\sigma_{eff}} = \frac{1}{\sigma_1} + \frac{1}{\sigma_2}$$

$$\Rightarrow \sigma_{eff} = \frac{2\sigma_1 \sigma_2}{\sigma_1 + \sigma_2}$$

33. (b) Initial length of rod =  $L$

Initial angular velocity,  $\omega_i = \omega$   
 When rod pivoted at one end is freely rotated in horizontal plane, then its angular momentum,

$$L_i = I_i \omega_i$$

$$L_i = \left( \frac{ML^2}{3} \right) \cdot \omega$$



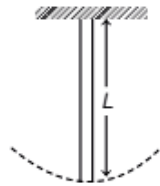

When temperature of the system is increased with temperature  $\Delta T$ , then change in length of rod  $\Delta L$  is given as

$$\Delta L = \alpha L \Delta T$$

Now, new length of the rod,

$$L' = \Delta L + L = \alpha L \Delta T + L = L(\alpha \Delta T + 1)$$

$$\Rightarrow L' = L(1 + \alpha \Delta T) \quad \dots(i)$$

Now, new angular momentum,

$$L_f = I_2 \omega_2 = \frac{ML'^2}{3} \cdot \frac{\omega}{2}$$

By the law of conservation of angular momentum,

$$L_f = L_i$$

$$I_2 \omega_2 = \frac{ML^2}{3} \cdot \omega$$

$$\frac{ML'^2}{3} \cdot \frac{\omega}{2} = \frac{ML^2}{3} \cdot \omega$$

$$\Rightarrow \frac{L'^2}{2} = L^2$$

$$\Rightarrow \frac{L^2(1 + \alpha \Delta T)^2}{2} = L^2 \quad [\text{from Eq. (i)}]$$

$$\Rightarrow (1 + \alpha \Delta T)^2 = 2$$

$$\Rightarrow 1 + \alpha^2 \Delta T^2 + 2\alpha \Delta T = 2$$

Since,  $\alpha$  is very small, hence the term  $\alpha^2 \Delta T^2$  may be neglected.

$$\therefore 1 + 2\alpha \Delta T = 2 \Rightarrow 2\alpha \Delta T = 1$$

$$\Rightarrow \Delta T = \frac{1}{2\alpha}$$

34. (b) As the gravitational field is uniform, therefore centre of gravity and the centre of mass are at same location.

$\therefore$  The location of centre of mass is

$$h = \frac{\int_0^\infty h dm}{\int_0^\infty dm}$$

$$h = \frac{\int_0^\infty h \rho dh}{\int_0^\infty \rho dh} \quad \dots(i)$$

But from barometric formula and gas law,

$$\rho = \rho_0 e^{-Mgh/RT}$$

$\therefore$  Putting the value of  $\rho$  in Eq. (i), we have

$$h = \frac{\int_0^\infty h \rho_0 e^{(-Mgh/RT)} dh}{\int_0^\infty \rho_0 e^{(-Mgh/RT)} dh} = \frac{RT}{Mg}$$

35. (b) Under isothermal conditions,

$$p_1 V_1 + p_2 V_2 = pV$$

$$\Rightarrow \left(p - \frac{4T}{a}\right) \frac{4}{3} \pi a^3 + \left(p - \frac{4T}{b}\right) \frac{4}{3} \pi b^3$$

$$= \left(p - \frac{4T}{c}\right) \frac{4}{3} \pi c^3$$

where,  $T$  is surface tension of soap bubble.

$$\Rightarrow p[c^3 - (a^3 + b^3)] - 4T(a^2 + b^2 - c^2) = 0$$

$$\Rightarrow T = \frac{p(c^3 - a^3 - b^3)}{4(a^2 + b^2 - c^2)}$$

36. (b,c)

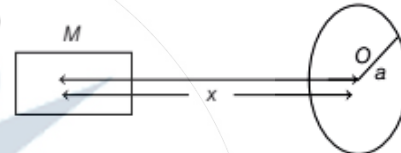

Magnetic field at the centre  $O$  of the circular coil due to bar magnet (axial position)

$$B = \frac{\mu_0}{4\pi} \frac{2M}{x^3}$$

Hence, option (a) is not true.

Induced emf,  $e = -\frac{d\phi}{dt} = -\frac{d}{dt} \cdot BA$

$$= -\frac{d}{dt} \cdot \frac{\mu_0}{4\pi} \cdot \frac{2M}{x^3} \pi a^2$$

$$= -\frac{\mu_0 M a^2}{2} \frac{d}{dt} \cdot \frac{1}{x^3}$$

$$= -\mu_0 M a^2 \cdot \left(\frac{-3}{x^4}\right) \frac{dx}{dt}$$

$$e = \frac{3\mu_0 M a^2}{x^4} \cdot \frac{dx}{dt}$$

$$\Rightarrow e \propto \frac{1}{x^4}$$

Hence, option (b) is true.

$$\text{Induced current, } I = \frac{e}{R} = \frac{3\mu_0 M a^2}{x^4 R} \frac{dx}{dt} \quad \dots(i)$$

$$\therefore \text{Magnetic moment, } \mu = IA = \frac{3\mu_0 M a^2}{x^4 R} \frac{dx}{dt} \pi a^2$$

$$\Rightarrow \mu = \frac{3\pi \mu_0 M}{x^4 R} \frac{dx}{dt} (a^4)$$

$$\mu \propto a^4$$

$\Rightarrow$  Hence, option (c) is true.

Net heat produced,

$$H \propto I^2$$

$$\Rightarrow H \propto \left(\frac{1}{x^4}\right)^2 \quad [\text{from Eq. (i)}]$$

$$\Rightarrow H \propto \frac{1}{x^8}$$

Hence, option (d) is not true.

37. (a,b) Given,  $E = a(\cos\omega_0 t + \sin\omega t + \cos\omega_0 t)$

$$\omega = 10^{15} \text{ s}^{-1}$$

$$\omega_0 = 5 \times 10^{15} \text{ s}^{-1}$$

Since,  $\omega < \omega_0$

$$\Rightarrow 2\pi\nu < 2\pi\nu_0$$

$$\Rightarrow \nu < \nu_0 \quad [\nu_0 = \text{threshold frequency}]$$

Hence, for light of frequency  $\omega$ , photoelectric effect is not possible.

According to Einstein's equation,

$$eV_0 = h\nu - h\nu_0$$

$$eV_0 = h\nu - \phi_0$$

Hence, stopping potential *versus* frequency graph will be straight line.

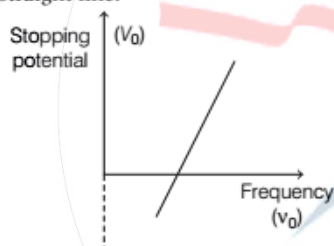

Work-function of metal surface,

$$\phi_0 = h\nu_0 = h\left(\frac{\omega_0}{2\pi}\right)$$

$$= 6.62 \times 10^{-34} \times \frac{5 \times 10^{15}}{2\pi}$$

$$= 5.27 \times 10^{-19} \text{ J}$$

$$= \frac{5.27 \times 10^{-19}}{1.6 \times 10^{-19}} \text{ eV}$$

$$= 3.29 \text{ eV}$$

$\therefore$  Maximum kinetic energy of photoelectron,

$$K_{\max} = -(eV_0) = -[-2] = 2 \text{ eV}$$

38. (b,c) Since, given  $p$ - $V$  diagram is not a cyclic process, hence the change in internal energy for the whole process is not zero.

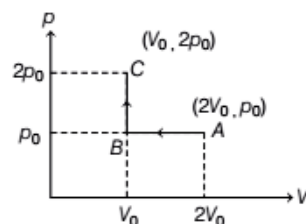

Heat rejected by the gas in path  $AB$  during isobaric compression,

$$dQ_{AB} = nC_p \Delta T$$

$$= 1 \cdot \frac{5}{2} R(T_B - T_A) \quad [\because n = 1]$$

$$= \frac{5R}{2} \left( \frac{p_0 V_0}{1 \times R} - \frac{2p_0 V_0}{1 \times R} \right) = -\frac{5p_0 V_0}{2}$$

Heat absorbed by the gas in path  $BC$  of isobaric process,

$$dQ_{BC} = nC_v \Delta T$$

$$= 1 \times \frac{3R}{2} (T_C - T_B)$$

$$= \frac{3R}{2} \left( \frac{2p_0 V_0}{1 \times R} - \frac{p_0 V_0}{1 \times R} \right) = \frac{3p_0 V_0}{2}$$

$$\text{Net heat} = dQ_{AB} + dQ_{BC}$$

$$= -\frac{5p_0 V_0}{2} + \frac{3p_0 V_0}{2} = -p_0 V_0$$

$\therefore$  Heat is rejected during the process.

Change in internal energy in process  $A \rightarrow B$ ,

$$\Delta U = nC_v \Delta T = 1 \times \frac{3}{2} R(T_B - T_A)$$

$$= \frac{3R}{2} \left( \frac{p_0 V_0}{1 \times R} - \frac{2p_0 V_0}{1 \times R} \right)$$

$$= -\frac{3}{2} p_0 V_0$$

Work done by the gas during entire process is  $W$ , then

$$W = W_{AB} + W_{BC}$$

$$= p_0(V_0 - 2V_0) + 0 = -p_0 V_0$$

39. (b,c) Mass,  $m = 0.02 \text{ kg}$

Potential energy,

$$U = Ax(x - 4) \text{ J}$$

$$\Rightarrow U = Ax^2 - 4Ax$$

$$\text{Force, } F = -\frac{dV}{dx} = -\frac{d}{dx}(Ax^2 - 4Ax)$$

$$\Rightarrow F = -2Ax + 4A \quad \dots(i)$$

This force is dependent on  $x$ , hence particle is not acted upon by a constant force.

From Eq. (i), it is clear that  $f \propto -x$

Hence, particle executes simple harmonic motion. Speed of particle is maximum at equilibrium position, i.e. when  $F = 0$

$$\text{i.e. } -2Ax + 4A = 0 \\ \Rightarrow x = 2m$$

Period of oscillation,

$$T = 2\pi\sqrt{\frac{m}{k}} \quad \dots(i)$$

From Eq. (i),  $F = -2Ax + 4A$

Since, value of  $k$  will be obtained in terms of  $A$ .

Therefore, the value of time period will be also obtained in terms of  $A$ , hence option (d) is not correct.

40. (a,d) The given situation is shown below

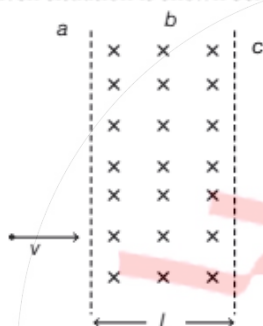

Since, charge particle enters into magnetic field  $B$  perpendicular to it, hence it performs a circular path in magnetic field. Radius of circular path,

$$r = \frac{mv}{Bq}$$

Charge particle will enter in region  $c$ , when  $L < 2r$

$$\Rightarrow L < 2\frac{mv}{Bq}$$

$$\Rightarrow \frac{LBq}{2m} < v \Rightarrow v > \frac{qLB}{2m}$$

$$\Rightarrow v > \left(\frac{1}{2}\right)\frac{qLB}{m}$$

i.e. When  $v > \frac{qLB}{m}$ , then particle surely will enter into region  $c$ , because  $\frac{qLB}{m} > \frac{qLB}{2m}$

Hence, option (a) is correct.

Since, charge particle enters into region  $c$ , hence path of the particle is a circle not in region  $b$ .

Hence, option (c) is not correct.

Time spent in region  $b$  is given as

$$T = \frac{2\pi m}{Bq} \text{ which is independent of } v.$$

Hence, option (d) is correct.

## Chemistry

41. (b) The exact order of the boiling points of the given compound is isopentane  $<$   $n$ -pentane  $<$  butanone  $<$  1-butanol.

The highest boiling will be of butanol because in butanol, molecules are associated due to extensive intermolecular hydrogen bonding.

Now butanone has higher boiling point from  $n$ -pentane and  $iso$ -pentane because butanone has stronger dipole-dipole interaction and  $n$ -pentane has higher boiling point than isopentane because of larger surface area, due to which  $n$ -pentane has greater van der Waals' force of attraction.

42. (d) All the atoms present in  $p$ -nitrobenzonitrile are in one plane as show in the structure

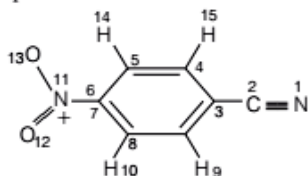

Therefore, the maximum number of atom in one plane in this case are 15.

43. (a) The total number of triple bonds present in cyclo (18) carbon are 9. Its structure is shown below:

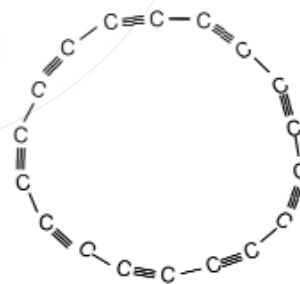

Structure of cyclo (18) carbon

44. (b) Resonating structures II and IV of  $p$ -nitro-N, N-dimethyl aniline are incorrect. In structure II and IV, valencies of N are not satisfied correctly.

All the correct resonating structures of *p*-nitro-N,N-dimethyl aniline are as follows

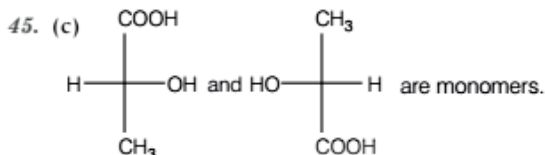
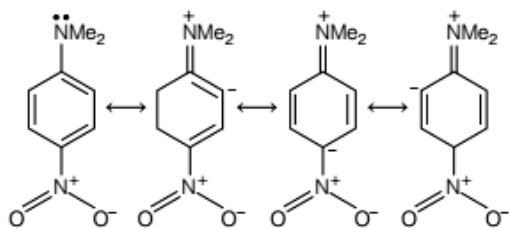

When the same compound is represented in different ways, then all the representations are known as homomers of each other.

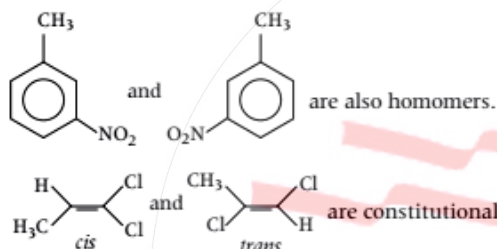

isomers.

Constitutional isomers are the compounds that have the same molecular formula and different connectivity.

46. (d) The correct order of acidity of the given compounds is acetylene < ethanol < *p*-nitrophenol < acetic acid.

Ethanol is stronger acid than acetylene. This is because after the loss of acidic proton ( $H^+$ ) the corresponding anion formed by ethanol is stabilised by the electronegative oxygen atom. Now *p*-nitrophenol is more acidic than ethanol because the phenoxide ion obtained after the deprotonation is stabilised by resonance effect and also by EWG effect (which is caused by  $-NO_2$  group).

Likewise, acetic acid is more acids than all of the given compounds as the formed carboxylate ion is stabilised by resonance which is due to the presence of electronegative oxygen atom.

47. (d) All the given dipeptides can be obtained from the amino acids glycine and alanine.

The general formula of amino acid is  $H_2N-CH(R)-COOH$ ,  $R$  is  $CH_3$  for alanine and  $H$  for glycine. The structure are as follows

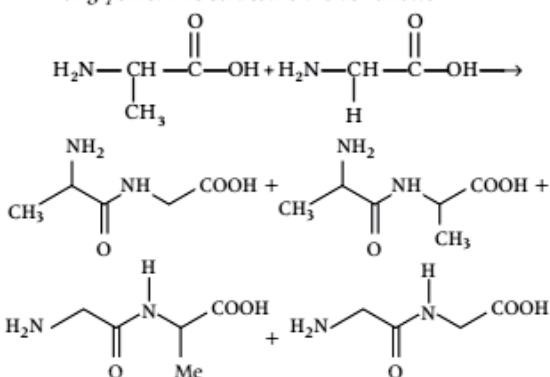

48. (d) Benzaldehyde reacts with 2 moles of methanol in presence of dry HCl to give which on reaction with dil. HCl

gives respective aldehyde and alcohol. Aldehyde on reaction with  $(CH_3CO)_2O$ ,

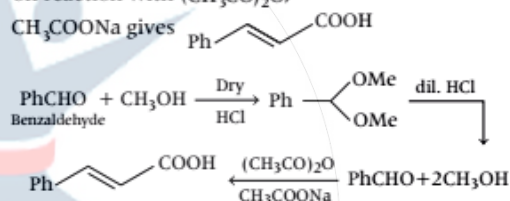

49. (c) The free energy change of a reaction is  $\Delta G^\circ = \Delta H^\circ - T\Delta S^\circ$

Now, a spontaneous reaction is one that releases free energy and therefore, the sign of  $\Delta G$  must be negative.

So, when  $\Delta H$  is negative and  $\Delta S$  is positive, the sign of  $\Delta G$  will be negative and the reaction will be spontaneous at all temperature.

50. (b) In acidic medium,

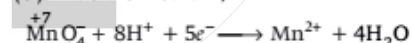

So, number of moles of  $MnO_4^- = \frac{1}{5}$  moles ... (i)

Also, in acidic medium,

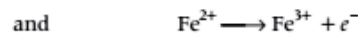
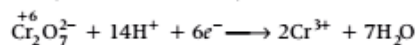

So, number of moles of  $Cr_2O_7^{2-} = \frac{1}{6}$  moles ... (ii)

Now, from Eq. (i)

$$\frac{1}{5} \text{ moles of MnO}_4^- = x \text{ moles of MnO}_4^-$$

$$\therefore \frac{1}{5} = x$$

$$5x = 1 \quad \dots \text{(iii)}$$

Put this value in Eq. (ii).

$$\frac{1}{6} \text{ will be } \frac{5x}{6}$$

So, the number of moles of  $\text{Cr}_2\text{O}_7^{2-}$  required to oxidise the same amount of  $\text{Fe}^{2+}$  in acidic medium is  $\frac{5}{6}x$  or  $0.83x$ .

51. (d) Density of the element ( $d$ ) =  $5.0 \text{ g cm}^{-3}$

$$\begin{aligned} \text{Edge length of unit cell (a)} &= 200 \text{ pm} \\ &= 200 \times 10^{-10} \text{ cm} \end{aligned}$$

$$d = \frac{Z \times M}{a^3 \times N_A}$$

[where  $M$  = mass of element

$N_A$  = Avogadro number

$Z$  = number of atoms per unit cell]

For body centred cubic lattice,  $Z = 2$

$$5 = \frac{2 \times M}{(200 \times 10^{-10})^3 \times 6.022 \times 10^{23}}$$

$$\begin{aligned} \Rightarrow M &= \frac{5 \times (200 \times 10^{-10})^3 \times 6.022 \times 10^{23}}{2} \\ &= \frac{5 \times (200)^3 \times 10^{30} \times 6.022 \times 10^{23}}{2} \end{aligned}$$

$$= 12.044 \text{ g}$$

Now, 12.044 g of element have  $\rightarrow 6.022 \times 10^{23}$  atoms

$$1 \text{ g will have } \rightarrow \frac{6.022 \times 10^{23}}{12.044} \text{ atoms}$$

$$100 \text{ g will have } \rightarrow \frac{6.022 \times 10^{23}}{12.044} \times 100 \text{ atoms}$$

$$= 0.5 \times 10^{25} \text{ atoms or}$$

$$= 5 \times 10^{24} \text{ atoms}$$

52. (d) Let two gases are A and B.

$u_1$  = molecular velocity of gas A

$u_2$  = molecular velocity of gas B

$m_1$  = molecular mass of gas A

$m_2$  = molecular mass of gas B

The root mean square velocity,  $u_{\text{rms}} = \sqrt{\frac{3RT}{M}}$

(where,  $M$  = molecular mass,  $R$  = gas constant)

For gas A,

$$u_1 = \sqrt{\frac{3RT}{m_1}}$$

$$u_1^2 = \frac{3RT}{m_1}$$

$$T = \frac{u_1^2 m_1}{3R} \quad \dots \text{(i)}$$

For gas B,

$$u_2 = \sqrt{\frac{3RT}{m_2}}$$

$$u_2^2 = \frac{3RT}{m_2}$$

$$T = \frac{u_2^2 m_2}{3R} \quad \dots \text{(ii)}$$

From Eq. (i) and (ii),

$$\frac{u_1^2 m_1}{3R} = \frac{u_2^2 m_2}{3R}$$

$$\therefore m_1 u_1^2 = m_2 u_2^2$$

53. (a)  $\Delta T_f = i \times k_f \times m$

$\Delta T_f$  = depression in freezing point of solvent

$i$  = van't Hoff factor

$k_f$  = freezing point depression constant

$m$  = molality

$$\begin{aligned} i &= \frac{\Delta T_f}{m \times k_f} = \frac{2}{\left( \frac{w_{\text{solute}} \times 100}{M_{\text{solute}} \times W_{\text{solvent}}} \right) \times 1.72} \\ &= \frac{2}{\left( \frac{20 \times 1000}{172 \times 50} \right) \times 1.72} \end{aligned}$$

$$\left[ \begin{aligned} M_{\text{solute}} &= M_{(\text{C}_{11}\text{H}_{18}\text{O}_2)} \\ &= 12 \times 11 + 8 \times 1 + 2 \times 16 \\ &= 172 \end{aligned} \right]$$

$$\Rightarrow i = \frac{2}{4} = 0.5$$

54. (a) The presence of catalyst does not change the value of equilibrium constant. It only increases the rate of forward and backward reaction to equal extent. So, the equilibrium constant in presence of catalyst at 2000 K is same as equilibrium constant in the absence of catalyst at 2000 K, i.e.  $4 \times 10^{-4}$ .

$$55. \text{ (a) For 1st order kinetic, } t_{1/2} = \frac{\ln 2}{k_1} = 40 \quad \dots \text{(i)}$$

$$\text{For 2nd order kinetics, } t_{1/2} = \frac{[A_0]}{2k_0} = 20 \quad \dots \text{(ii)}$$

From Eq. (i),

$$40 = \frac{\ln 2}{k_1}$$

$$\Rightarrow k_1 = \frac{\ln 2}{40} \quad \dots(\text{iii})$$

From Eq. (ii),

$$20 = \frac{[A_0]}{2k_0} \quad \dots(\text{iv})$$

$$k_0 = \frac{[A_0]}{40}$$

$$\text{Now, ratio } \left( \frac{k_1}{k_0} \right) = \frac{\ln 2}{40} \times \frac{40}{[A_0]}$$

$$= \frac{\ln 2}{[A_0]} = \frac{0.693}{1.386 \text{ mol dm}^{-3}}$$

$$= 0.5 \text{ mol}^{-1} \text{ dm}^3$$

56. (d) Among the given solutions, NaCl, KNO<sub>3</sub> and HCl are strong electrolytes but conductivity also depends upon size of ions. Smaller the size of ions, greater its conductance, hence greater is the conductivity than larger ions. So, out of NaCl, KNO<sub>3</sub> and HCl ions, H<sup>+</sup> is the smallest and therefore, 0.1 M HCl will have highest conductivity.

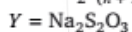
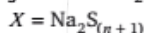
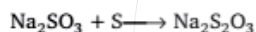
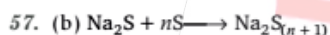

58. (d) Let a weak monoacidic base is BOH. BOH is neutralised as follow



At point of equivalence, all BOH get converted into salt and the concentration of H<sup>+</sup> ions is due to the hydrolysis of resultant salt, BCl.

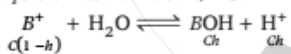

Volume of HCl used

$$V_a = \frac{N_b V_b}{N_a} = \frac{2.5 \times 2 \times 15}{2 \times 5} = 7.5 \text{ mL}$$

Now, the concentration of salt, [BCl]

$$= \frac{\text{Conc. of base}}{\text{Total volume}} = \frac{2 \times 2.5}{5(7.5 + 2.5)} = \frac{1}{10} = 0.1$$

$$\text{So, } K_h = \frac{Ch^2}{1-h} = \frac{K_w}{K_b} = \frac{10^{-14}}{10^{-12}} = 10^{-2}$$

$$\text{or } \frac{Ch^2}{1-h} = 10^{-2}$$

$$\frac{0.1 \times h^2}{1-h} = 10^{-2}$$

On calculating,  $h = 0.27$  which is significant, not negligible.

$$\therefore [\text{H}^+] = Ch = 0.1 \times 0.27 = 2.7 \times 10^{-2} \text{ M}$$

59. (d) For salt MX,  $K_{sp} = [S][S]$

$$K_{sp} = 4 \times 10^{-8} \text{ (given)}$$

$$\therefore 4 \times 10^{-8} = [S]^2$$

$$\therefore S = 2 \times 10^{-4}$$

For salt MX<sub>2</sub>,  $K_{sp} = [S][2S]^2$

$$K_{sp} = 3.2 \times 10^{-14}$$

$$[S] = \left( \frac{3.2 \times 10^{-14}}{4} \right)^{1/3}$$

$$= (8 \times 10^{-15})^{1/3} = 2 \times 10^{-5}$$

For salt MX<sub>3</sub>,  $K_{sp} = [3S]^3[S]$

$$K_{sp} = 2.7 \times 10^{-15}$$

$$[S] = \left( \frac{2.7 \times 10^{-15}}{27} \right)^{1/4}$$

$$= (10^{-16})^{1/4} = 10^{-4}$$

$\therefore$  Solubility of MX order is

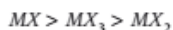

60. (c) Reduction hydrogen half-cell is H<sup>+</sup>|(xM)|Pt(H<sub>2</sub>); Pressure p<sub>H<sub>2</sub></sub>

Half-cell reaction is

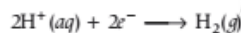

$$n = 2$$

Reaction quotient  $\Rightarrow Q = \frac{p_{\text{H}_2}}{[\text{H}^+]^2}$

$$E_{\text{red}} = E_{\text{red}}^\circ - \frac{0.0591}{n} \log Q$$

$$E_{\text{red}} = - \frac{0.0591}{2} \log Q$$

$$\text{Case (a), } \log Q = \log \frac{1}{1} = 0$$

$$\therefore E_{\text{red}} = 0$$

$$\text{Case (b), } \log Q = \log \frac{1}{4} = -ve$$

$$\therefore E_{\text{red}} = +ve$$

$$\text{Case (c), } \log Q = \log \frac{2}{1} = +ve$$

$$\therefore E_{\text{red}} = -ve$$

$$\text{Case (d), } \log Q = \log \frac{2}{4} = -ve$$

$$\therefore E_{\text{red}} = +ve$$

$\therefore E_{\text{red}}$  is negative for option (c).

61. (d) Solubility of saturated solution = Solubility product

$$\therefore K_{sp} = 4 \times 10^{-5} \text{ (for BaSO}_4\text{)}$$

Let the solubility of BaSO<sub>4</sub> in 0.1 M Na<sub>2</sub>SO<sub>4</sub> be  $x$ .

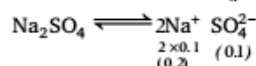
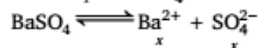

$$\therefore \text{Total } (\text{SO}_4^{2-}) = x + 0.1$$

$$= 0.1 \text{ M}$$

$$\text{Thus, } K_{sp} = [\text{Ba}^{2+}][\text{SO}_4^{2-}]$$

$$4 \times 10^{-5} = [x](0.1)$$

$$\therefore x = 4 \times 10^{-4}$$

$$\therefore \text{Solubility} = 4 \times 10^{-4} \text{ M}$$

62. (c) The given reaction is as follows:

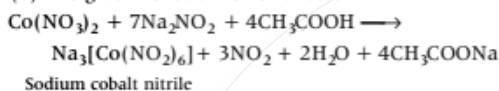

With the salt of potassium, sodium cobalt nitrile forms insoluble double salt  $\text{K}_2\text{Na}[\text{Co}(\text{NO}_2)_6] \cdot \text{H}_2\text{O}$ . This salt is yellow coloured ppt.

63. (b) The metal ( $M$ ) is copper and the reactions are as follows:

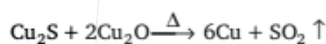
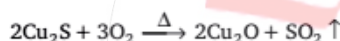

64. (d) When CO<sub>2</sub> is passed through ammoniacal solution of NaCl, sodium bicarbonate (NaHCO<sub>3</sub>) and (NH<sub>4</sub>Cl) are formed.

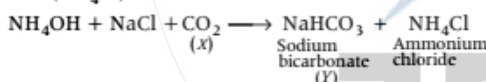

On further heating NaHCO<sub>3</sub>, we get Na<sub>2</sub>CO<sub>3</sub>.

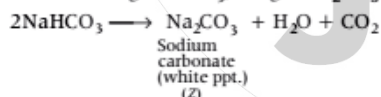

65. (a) Structure of ozone (i.e. O<sub>3</sub>) has delocalised  $\pi$ -electrons. Its resonance structure are as follows:

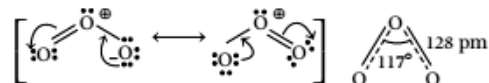

66. (b) The structure of the hydronium ion is pyramidal because it has three bonding pairs of electrons and one lone pair of electrons.

Its structure is as follows:

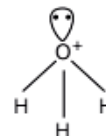

Hybridisation =  $sp^3$  and shape = pyramidal

67. (b) Mass on the reactant side = 18.00567 amu  
Mass of the proton = 1.00782 amu  
Energy absorbed in the reaction = 1.16 MeV  
= 0.00124 amu

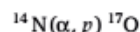

This reaction can be simplified as

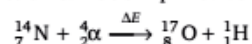

where,  $\Delta E$  is the energy absorbed.

In this reaction, highly energetic alpha particle with kinetic energy 1.16 MeV are absorbed by  ${}^{14}_7\text{N}$  nucleus to form  ${}^{17}_8\text{O}$  isotope and a proton.

Hence,

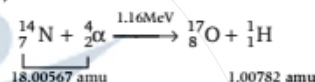

According to conservation of mass-energy.

$$18.00567 \text{ amu} = ({}^{17}_8\text{O} + 1.0078 - 0.00124) \text{ amu}$$

$${}^{17}_8\text{O} = 18.00567 - 1.0078 + 0.00124$$

$$= 16.99914 \text{ amu}$$

68. (a) A solution of NaNO<sub>3</sub>, when treated with a mixture of Zn dust and NaOH (caustic soda) yields ammonia gas.

Complete reaction is as follows

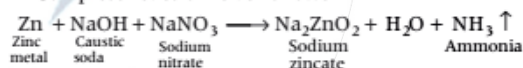

69. (a) In  $\text{K}_3[\text{Fe}(\text{CN})_6]$  Fe present in +3 oxidation state outer electronic configuration of  $\text{Fe}^{3+}$  =



As CN is a strong field ligand. So, it causes the pairing of electrons.

Therefore,  $\text{K}_3[\text{Fe}(\text{CN})_6] =$

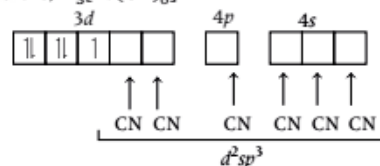

Thus, in this complex, number of unpaired electron is one.

In  $K_4[Fe(CN)_6]Fe$ , present in +2 oxidation state outer electronic configuration of  $Fe^{2+}$

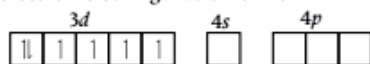

As in this case also the ligand is CN (which is a strong field). So, it again causes the pairing of the electron. This can be shown in following way.

$K_4[Fe(CN)_6] =$



Thus, in this case the number of unpaired electron is zero.

70. (d) When two complexes have same number of unpaired electrons, they have same value of magnetic moment. The number of unpaired electrons present in  $[Cu(H_2O)_6]^{2+}$ ,  $[Mn(H_2O)_6]^{4+}$ ,  $[Mn(H_2O)_6]^{3+}$ ,  $[Fe(H_2O)_6]^{3+}$  and  $[Cr(H_2O)_6]^{3+}$  are 0, 3, 4, 5 and 3 respectively.

Thus, the magnetic moment of  $[Mn(H_2O)_6]^{3+}$  and  $[Cr(H_2O)_6]^{3+}$  are identical as they have same number of unpaired electrons (i.e., 3).

71. (a) Methoxymethyl chloride ( $CH_3OCH_2Cl$ ) hydrolysed most easily and neopentyl chloride  $[(CH_3)_3C-Cl]$  hydrolysed most slowly. Primary halide readily undergoes  $S_N2$  mechanism and forms intermediate whereas tertiary halides due to steric hinderance reacts slowly with water.
72. (c) Phenol on nitration with dil.  $HNO_3$  gives *p*-nitro phenol (*X*) which on heating with  $Zn/HCl$ , form *p*-amino phenol, which on acetylation with  $[CH_3(CO)_2O]$  gives *p*-hydroxy acetanilide. Reaction is as follows :

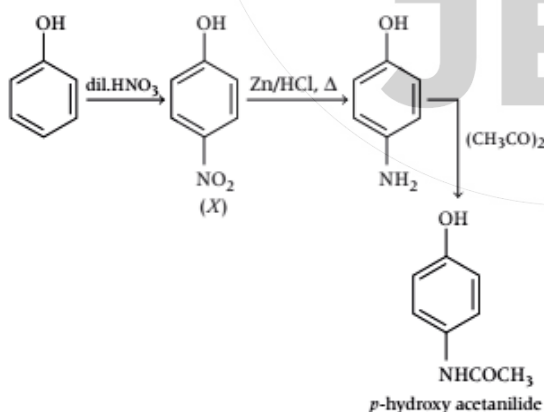

73. (a) de-Broglie wavelength,  $\lambda = \frac{h}{mv}$

$$\therefore \frac{\lambda_{He}}{\lambda_{Ne}} = \frac{M_{Ne}}{M_{He}} = \frac{20}{4}$$

$$\therefore \lambda_{He} = 5\lambda_{Ne}$$

74. (a) Given,

$$x_{\text{solute}} = 0.1$$

$$\text{Molarity} = \text{Molality}$$

$$\text{Density of solution} = 2 \text{ g cm}^{-3}$$

$$= \frac{2 \times 10^{-3}}{10^{-6}} \text{ kg}$$

$$= 2 \times 10^3 \text{ kg/m}^3$$

$$= 2 \text{ kg/L}$$

$$\frac{m_{\text{solute}}}{M_{\text{solute}}} = \frac{m_{\text{solute}}}{M_{\text{solute}}}$$

$$\text{Volume} = \text{Mass of solvent (kg)}$$

$$\text{Volume of solution} = \text{Mass of solvent (kg)}$$

$$\frac{\text{Mass of solution}}{\text{Mass of solvent}} = \text{Mass of solvent}$$

$$\therefore \frac{\text{Mass of solution}}{\text{Mass of solvent}} = 2$$

$$\therefore \frac{\text{Mass of solute} + \text{Mass of solvent}}{\text{Mass of solvent}} = 2$$

$$\therefore \frac{\text{Mass of solute}}{\text{Mass of solvent}} = 1$$

...(i)

$$\frac{\eta_{\text{solute}}}{\eta_{\text{solute}} + \eta_{\text{solvent}}} = 0.1$$

$$\frac{m_{\text{solute}}}{M_{\text{solute}}} = 0.1$$

$$\frac{m_{\text{solute}} + m_{\text{solvent}}}{M_{\text{solute}} + M_{\text{solvent}}}$$

$$\frac{1}{M_{\text{solute}}} = 0.1$$

$$\frac{1}{M_{\text{solute}}} + \frac{1}{M_{\text{solvent}}}$$

$$\therefore \frac{M_{\text{solute}}}{M_{\text{solvent}}} = 9$$

{ $\because M_{\text{solute}} = m_{\text{solvent}}$  using (i)}

75. (d)  $IE_{Na} = 490 \text{ kJ/mol}$

$$\eta_{Na} = \frac{m_{Na}(g)}{M_{Na}}$$

$$= \frac{575 \times 10^{-3}}{23}$$

$$\therefore IE_{Na} = 490 \times 0.25 \times 10^{-3}$$

$$= 0.1225 \text{ kJ}$$



76. (b,c) Butyne ( $\text{Me}-\text{C}\equiv\text{C}-\text{Me}$ ) on reaction with  $\text{Na} / \text{NH}_3(\text{liq.})$  undergoes reduction to give but-2-ene which on reaction with dil. alkaline  $\text{KMnO}_4$  gives diol.

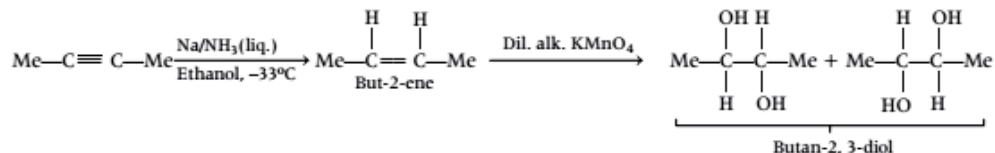

77. (d) Complete reaction is as follows :

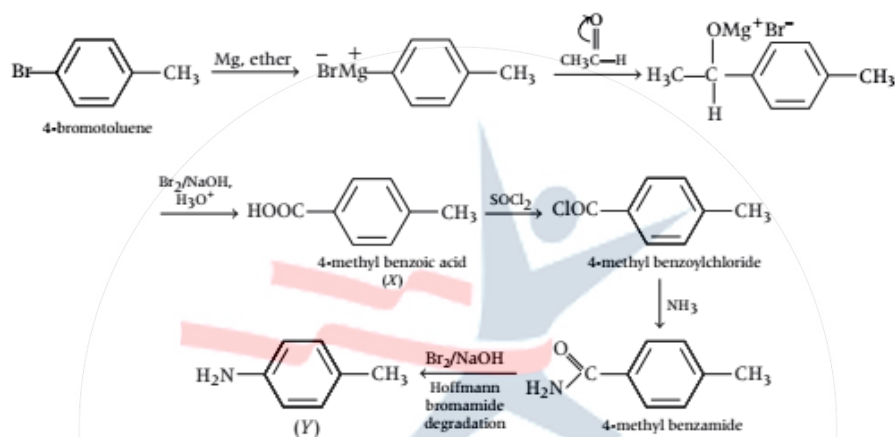

78. (c, d) Buffer solutions are made by mixing weak acid with its salt of strong base or mixing weak base with its salt of strong acid. It is never formed by mixing strong acid and strong base. The pair(s) of solutions which form a buffer upon mixing are (c)  $\text{HNO}_3$  and  $\text{CH}_3\text{COO}^-\text{Na}^+$ , (d) i.e.  $\text{CH}_3\text{COOH}$  and  $\text{CH}_3\text{COO}^-\text{Na}^+$ .
79. (b, c) Reaction of silver nitrate solution with phosphorus acid produces phosphoric acid and metallic silver. Complete reaction is as follows:
- $$\text{H}_3\text{PO}_3 + \text{AgNO}_3 + \text{H}_2\text{O} \longrightarrow \text{H}_3\text{PO}_4 + \text{Ag} \downarrow + 2\text{HNO}_3$$
- Phosphorus acid Phosphoric acid
80. (b, c, d)  $\text{N}_2\text{H}_4$  and  $\text{H}_2\text{O}_2$  show similarity in reducing and oxidising nature. They have same hybridisation of central atoms i.e.  $sp^3$ . The structure of hydrazine and hydrogen peroxide as follows.

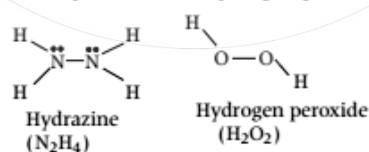

## Mathematics

1. (c) Given,  $I = \lim_{x \rightarrow 0} \left( \frac{e^x - x - 1 - \frac{x^2}{2}}{x^2} \right)$

$$= \lim_{x \rightarrow 0} \frac{\sin \left( \frac{e^x - x - 1 - \frac{x^2}{2}}{x^2} \right)}{\frac{e^x - x - 1 - \frac{x^2}{2}}{x^2}} \times \frac{e^x - x - 1 - \frac{x^2}{2}}{x^2}$$

$$= \lim_{x \rightarrow 0} \frac{e^x - x - 1 - \frac{x^2}{2}}{x^2}$$

$$= \lim_{x \rightarrow 0} \frac{e^x - 1 - 0 - x}{2x}$$

$$= \lim_{x \rightarrow 0} \frac{e^x - 1}{2}$$

$$= \frac{1}{2} \lim_{x \rightarrow 0} \frac{e^x - 1}{x} \times x$$

$$= \frac{1}{2} \lim_{x \rightarrow 0} \frac{e^x - 1}{x} \times \lim_{x \rightarrow 0} x$$

$$= 0$$

2. (b) Given,  $|f'(x)| \leq 5$  for all  $x$

$$\Rightarrow \int_0^1 -5 dx \leq \int_0^1 f'(x) dx \leq \int_0^1 5 dx$$

$$\Rightarrow -5 \leq f(1) - 0 \leq 5$$

$$\Rightarrow -5 \leq f(1) \leq 5$$

$$\Rightarrow f(1) \in [-5, 5]$$

3. (c) Let  $I = \int \frac{\sin 2x}{(a + b \cos x)^2} dx$

$$\Rightarrow I = \int \frac{2 \sin x \cos x}{(a + b \cos x)^2} dx$$

Put  $a + b \cos x = t$

$$\Rightarrow \cos x = \frac{t-a}{b} \Rightarrow -b \sin x dx = dt$$

$$I = -\frac{2}{b} \int \left( \frac{t-a}{b} \right) \frac{1}{t^2} dt$$

$$= -\frac{2}{b^2} \int \frac{t-a}{t^2} dt$$

$$= -\frac{2}{b^2} \left[ \int \frac{1}{t} dt - \int \frac{a}{t^2} dt \right]$$

$$= -\frac{2}{b^2} \left[ \log(t) - a \frac{t^{-2+1}}{-2+1} \right] + C$$

$$= -\frac{2}{b^2} \left[ \log |t| + \frac{a}{t} \right] + C$$

$$\therefore I = -\frac{2}{b^2} \left[ \log |a + b \cos x| + \frac{a}{a + b \cos x} \right] + C$$

$$\Rightarrow \alpha = -\frac{2}{b^2}$$

4. (c) Given,  $g(x) = \int_x^{2x} \frac{f(t)}{t} dt, x > 0$

$$\Rightarrow g'(x) = \frac{f(2x)}{2x} \frac{d}{dx}(2x) - \frac{f(x)}{x} \frac{d}{dx}(x)$$

(Using Leibnitz Rule for Differentiation)

$$= \frac{f(2x)}{2x} (2) - \frac{f(x)}{x}$$

$$= \frac{f(2x) - f(x)}{x}$$

$$= \frac{f(x) - f(x)}{x} \quad (\because f(2x) = f(x))$$

$$\Rightarrow g'(x) = 0$$

$$\Rightarrow g(x) \text{ is constant function}$$

5. (b) We have,

$$= \int_1^3 \frac{|x+1|}{|x-2| + |x-3|} dx$$

$$= \int_1^2 \frac{x-1}{-x+2-x+3} dx + \int_2^3 \frac{x-1}{2x-2-x+3} dx$$

( $\because |x| = x, x \geq 0, -x, x < 0$ )

$$= \int_1^2 \frac{x-1}{-2x+5} dx + \int_2^3 (x-1) dx$$

$$= -\frac{1}{2} \int_1^2 \frac{2-2x+2}{-2x+5} dx + \left( \frac{x^2}{2} - x \right)_2^3$$

$$= -\frac{1}{2} \int_1^2 \frac{2-2x+5-3}{-2x+5} dx + \left( \frac{9}{2} - 3 \right) - (2-2)$$

$$= -\frac{1}{2} \left[ \int_1^2 \frac{2-2x+5}{-2x+5} dx - \int_1^2 \frac{3}{-2x+5} dx + \frac{3}{2} \right]$$

$$= -\frac{1}{2} \left[ \int_1^2 dx + \frac{3}{2} \log[-2x+5]_1^2 \right] + \frac{3}{2}$$

$$= \frac{3}{4} \log 3 + 1$$

$$\begin{aligned}
 6. \text{ (c)} \int_{-\frac{1}{2}}^{\frac{1}{2}} \left\{ \left( \frac{x+1}{x-1} \right)^2 + \left( \frac{x-1}{x+1} \right)^2 - 2 \right\}^{\frac{1}{2}} dx \\
 &= \int_{-\frac{1}{2}}^{\frac{1}{2}} \left[ \left( \frac{x+1}{x-1} - \frac{x-1}{x+1} \right)^2 \right]^{\frac{1}{2}} dx \\
 &= \int_{-\frac{1}{2}}^{\frac{1}{2}} \left[ \frac{4x}{x^2-1} \right] dx \\
 &= \int_{-\frac{1}{2}}^0 \left[ \frac{4x}{x^2-1} \right] dx - \int_0^{\frac{1}{2}} \left[ \frac{4x}{x^2-1} \right] dx \\
 &= -4 \int_{-\frac{1}{2}}^0 \frac{x}{1-x^2} dx + 4 \int_0^{\frac{1}{2}} \frac{x}{1-x^2} dx \\
 &= 2[\log(1-x^2)]_{-\frac{1}{2}}^0 - 2[\log(1-x^2)]_0^{\frac{1}{2}} \\
 &= -2 \log\left(1 - \frac{1}{4}\right) - 2 \log\left(1 - \frac{1}{4}\right) \\
 &= -4 \log \frac{3}{4} = 4 \log \frac{4}{3}
 \end{aligned}$$

$$7. \text{ (c) Let } I = \int_{\log_e 2}^x \frac{1}{e^x - 1} dx$$

$$\begin{aligned}
 \text{Put } e^x - 1 = t \Rightarrow e^x = t + 1 \\
 e^x dx = dt \\
 \Rightarrow dx = \frac{dt}{e^x} = \frac{dt}{t+1}
 \end{aligned}$$

$$\text{When } x = x, t = e^x - 1$$

$$\text{and when } x = \log_e 2, t = e^{\log_e 2} - 1 = 2 - 1 = 1$$

$$I = \int_1^t \frac{1}{t(t+1)} dt$$

$$\frac{1}{t(t+1)} = \frac{A}{t} + \frac{B}{t+1}$$

$$1 = A(t+1) + B(t)$$

$$t = 0, A = 1$$

$$t + 1 = 0 \Rightarrow t = -1, B = -1$$

$$\therefore \frac{1}{t(t+1)} = \frac{1}{t} - \frac{1}{t+1}$$

$$\Rightarrow I = \int_1^t \left( \frac{1}{t} - \frac{1}{t+1} \right) dt$$

$$= [\log_e t - \log_e(t+1)]_1^t$$

$$= \left[ \log_e \frac{t}{t+1} \right]_1^t$$

$$= \left[ \log_e \frac{t}{t+1} - \log_e \frac{1}{2} \right]$$

$$= \log_e \frac{2t}{t+1}$$

$$\therefore \frac{2t}{2t+1} = \frac{3}{2}$$

$$\Rightarrow 4t = 3t + 3$$

$$\Rightarrow t = 3$$

$$\text{Now, } e^x - 1 = t$$

$$\Rightarrow e^x - 1 = 3$$

$$\Rightarrow e^x = 4$$

$$\Rightarrow x = \log_e 4$$

8. (c) Equation of normal

$$Y - y = \frac{-1}{dy/dx} (X - x)$$

When  $y = 0$

$$\text{Then, } G = \left( x + y \frac{dy}{dx}, 0 \right)$$

According to the question,

$$x + y \frac{dy}{dx} = 2x \Rightarrow y \frac{dy}{dx} = x$$

$$\Rightarrow \int y dy = \int x dx$$

$$\Rightarrow \frac{y^2}{2} = \frac{x^2}{2} + C \Rightarrow \frac{y^2 - x^2}{2} = C$$

$\Rightarrow$  which is hyperbola.

9. (b) We know that the equation of an ellipse whose centre is at origin is  $\frac{x^2}{a^2} + \frac{y^2}{b^2} = 1$

Differentiate both sides w.r.t  $x$ , we get

$$\frac{2x}{a^2} + \frac{2y}{b^2} \frac{dy}{dx} = 0$$

$$\Rightarrow \frac{2y}{b^2} \frac{dy}{dx} = -\frac{2x}{a^2}$$

$$\Rightarrow \frac{y}{x} \frac{dy}{dx} = -\frac{b^2}{a^2}$$

Again differentiate both sides w.r.t  $x$ , we get

$$\frac{y}{x} \frac{d}{dx} \left( \frac{dy}{dx} \right) + y' \frac{d}{dx} \left( \frac{y}{x} \right) = 0$$

$$\Rightarrow \frac{y}{x} y'' + y' \left( \frac{xy' - y \times 1}{x^2} \right) = 0$$

$$\Rightarrow \frac{y}{x} y'' + y' \left( \frac{xy' - y}{x^2} \right) = 0$$

$$\Rightarrow xyy'' + x(y')^2 - yy' = 0$$

Which is the required differential equation.

**10.** (a) Given,  $x \frac{dy}{dx} + y = x \frac{f(xy)}{f'(xy)}$

$$\Rightarrow \frac{d}{dx}(xy) = x \frac{f(xy)}{f'(xy)}$$

$$\Rightarrow \frac{f'(xy)}{f(xy)} d(xy) = x dx$$

$$\Rightarrow \int \frac{f'(xy)}{f(xy)} d(xy) = \int x dx$$

$$\Rightarrow \log |f(xy)| = \frac{x^2}{2} + C$$

$$\Rightarrow |f(xy)| = e^{\frac{x^2}{2} + C}$$

$$= ke^{\frac{x^2}{2}}$$

**11.** (d)  $-y = (x-1)^2 - 1$

$$y = 1 - (x-1)^2$$

Hence the required area is

$$\begin{aligned} \int_0^1 [1 - (x-1)^2] dx &= \left[ x - \frac{(x-1)^3}{3} \right]_0^1 \\ &= 1 - \left[ -\frac{(-1)^3}{3} \right] \\ &= 1 - \frac{1}{3} = \frac{2}{3} \end{aligned}$$

Hence,  $y = \frac{2}{3}x$  will divide the entire area in 2 equal parts.

**12.** (c)  $\int_0^5 \max \{x^2, 6x-8\} dx$

$$= \int_0^2 x^2 dx + \int_2^4 (6x-8) dx + \int_4^5 x^2 dx$$

$$= \left[ \frac{x^3}{3} \right]_0^2 + \left[ \frac{6x^2}{2} - 8x \right]_2^4 + \left[ \frac{x^3}{3} \right]_4^5$$

$$= \frac{8}{3} + [3x^2 - 8x]_2^4 + \frac{125}{3} - \frac{64}{3}$$

$$= (48 - 32 - 12 + 16) + \frac{69}{3}$$

$$= 20 + 23$$

$$= 43$$

**13.** (b) Given, radius of circular track is 10 m.

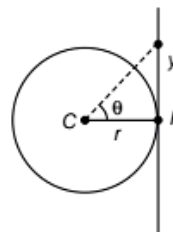

and speed of man = 10 m/sec. i.e.  $v = r \frac{d\theta}{dt} = 10$

Now,  $\tan \theta = \frac{y}{r}$

$$\Rightarrow y = r \tan \theta$$

$$\Rightarrow \frac{dy}{dt} = r \sec^2 \theta \cdot \frac{d\theta}{dt}$$

$$= \sec^2 \theta \cdot r \frac{d\theta}{dt}$$

$$= \sec^2 60^\circ \cdot (10)$$

$$= (2)^2 \times 10$$

$$= 40 \text{ m/sec.}$$

**14.** (c) Let B travels  $x$  units,

$$v = u + at$$

According to the problem,

$$f't = f(t+m)$$

$$\Rightarrow \frac{f' - f}{f} = \frac{m}{t}$$

$$\Rightarrow t^2 = m^2 \left( \frac{f}{f' - f} \right)^2 \quad \dots(i)$$

Again,  $n + x = \frac{1}{2} f(t+m)^2$

$$\Rightarrow n + \frac{1}{2} f't^2 = \frac{1}{2} f(t+m)^2 \quad \dots(ii)$$

Now from Eqs. (i) and (ii), we get

$$\frac{m}{n} = \frac{2(f' - f)}{mff'}$$

$$\Rightarrow (f' - f)n = \frac{1}{2} f' m^2$$

**15.** (b) Given,  $\alpha + 3\beta$  is collinear with  $\gamma$

$$\therefore \alpha + 3\beta = \lambda_1 \gamma$$

$$\Rightarrow \beta = \frac{\lambda_1}{3} \gamma - \frac{\alpha}{3} \quad \dots(i)$$

and  $\beta + 2\gamma$  is collinear with  $\alpha$

$$\therefore \beta + 2\gamma = \lambda_2 \alpha$$

$$\Rightarrow \beta = \lambda_2 \alpha - 2\gamma \quad \dots(ii)$$

From Eqs. (i) and (ii), we get

$$\frac{\lambda_1}{3} \gamma - \frac{\alpha}{3} = \lambda_2 \alpha - 2\gamma$$

$$\Rightarrow \alpha \left( \lambda_2 + \frac{1}{3} \right) = \gamma \left( \frac{\lambda_1}{3} + 2 \right)$$

$$\Rightarrow \lambda_2 + \frac{1}{3} = 0 \text{ and } \frac{\lambda_1}{3} + 2 = 0$$

$$\Rightarrow \lambda_2 = -\frac{1}{3} \text{ and } \frac{\lambda_1}{3} = -2$$

$$\Rightarrow \lambda_1 = -6 \text{ and } \lambda_2 = -\frac{1}{3}$$

From Eqs. (i) and (ii),  $\beta = -2\gamma - \frac{\alpha}{3}$

$$\therefore \alpha + 3\beta + 6\gamma = \alpha + 3 \left( -2\gamma - \frac{\alpha}{3} \right) + 6\gamma$$

$$= 0$$

16. (c) Given,  $f(x) = |x^2 - 1|$ ,  $x \in R$ .  
The graph of  $f(x)$  is clearly, from graph.

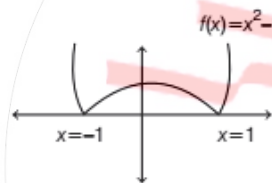

$f(x)$  has a local minima at  $x = \pm 1$  and has local maxima at  $x = 0$

17. (d) Given,

$$\frac{2}{3} \log_b a + \frac{3}{5} \log_c b + \frac{5}{2} \log_a c = 3$$

$$\Rightarrow \frac{2 \log a}{3 \log b} + \frac{3 \log b}{5 \log c} + \frac{5 \log c}{2 \log a} = 3$$

Since, A.M =  $\frac{\frac{2}{3} \log_b a + \frac{3}{5} \log_c b + \frac{5}{2} \log_a c}{3}$

$$= \frac{3}{3} = 1$$

and G.M =  $\left( \frac{2}{3} \log_b a \cdot \frac{3}{5} \log_c b \cdot \frac{5}{2} \log_a c \right)^{\frac{1}{3}}$

$$= \frac{2 \log a}{3 \log b} \times \frac{3 \log b}{5 \log c} \times \frac{5 \log c}{2 \log a} = 1$$

$\therefore$  A.M. = G.M

$$\therefore \frac{2 \log a}{3 \log b} = 1 \Rightarrow a^2 = b^3$$

$$\Rightarrow a = (3^6)^{\frac{1}{2}} = 3^3 = 27$$

18. (a) Given,  $h(p) = \frac{1}{2} \{h(p+1) + h(p-1)\}$   
for every  $p = 1, 2, \dots, 99$

$$2h(p) = h(p+1) + h(p-1)$$

$\Rightarrow h(p-1), h(p), h(p+1)$  are in AP.

Now,  $h(100) = 20$

$$\Rightarrow h(0) + 99d = 20$$

$$\Rightarrow 5 + 99d = 20 \quad (\because h(0) = 5)$$

$$\Rightarrow d = \frac{15}{99} = \frac{5}{33}$$

$\therefore h(1) = h(0) + d$

$$= 5 + \frac{5}{33} = 5 + 0.15$$

$$= 5.15$$

19. (d) Let  $z = e^{i\theta}$

Also, let  $w = \frac{e^{i\theta}}{1 - e^{2i\theta}} = \frac{1}{e^{-i\theta} - e^{i\theta}}$

$$= \frac{1}{-2 \cdot i \sin \theta} = \frac{i}{2 \sin \theta}$$

$\Rightarrow w$  is purely imaginary  
 $\Rightarrow$  Locus of point is Y-axis.

20. (c) We have,  $z^2 = w^2$

$$\Rightarrow z^2 - w^2 = 0$$

$$\Rightarrow (z - w)(z + w) = 0$$

$$\Rightarrow z = w, z = -w$$

$$\Rightarrow |z| = |w|$$

$\therefore B \subset A$

21. (c) Given,  $x^2 - 6x - 2 = 0$

$$\Rightarrow x^{n-2}(x^2 - 6x - 2) = 0$$

$$\Rightarrow x^n - 6x^{n-1} - 2x^{n-2} = 0$$

When,  $n = 10$ ,

$$\text{Then, } x^{10} - 6x^9 - 2x^8 = 0$$

$$\Rightarrow x^{10} - 2x^8 = 6x^9$$

Since,  $\alpha$  and  $\beta$  are roots of (i).

$\therefore \alpha^{10} - 2\alpha^8 = 6\alpha^9$

and  $\beta^{10} - 2\beta^8 = 6\beta^9$

$\therefore (\alpha^{10} - \beta^{10}) - 2(\alpha^8 - \beta^8) = 6(\alpha^9 - \beta^9)$

$$\Rightarrow a_{10} - 2a_8 = 6a_9 \quad (\because a_n = \alpha^n - \beta^n) \quad \text{27. (c) Given,}$$

$$\Rightarrow \frac{a_{10} - 2a_8}{2a_9} = 3$$

22. (d) For  $x \in \mathbb{R}, x \neq -1$

$$(1+x)^{2016} + x(1+x)^{2015} + x^2(1+x)^{2014} + \dots + x^{2016} = \sum_{i=0}^{2016} a_i \cdot x^i$$

Here, coefficient of  $x^{17}$

$$= {}^{2016}C_{17} + {}^{2015}C_{16} + {}^{2014}C_{15} + \dots + {}^{1999}C_0$$

$$= {}^{2016}C_{1999} + {}^{2015}C_{1999} + {}^{2014}C_{1999} + \dots + {}^{1999}C_{1999}$$

$$(\because {}^nC_r + {}^nC_{r-1} = {}^{n+1}C_r)$$

$$= {}^{2017}C_{2000} = \frac{(2017)!}{(2000)!(2017-2000)!}$$

$$= \frac{2017!}{(2000)!(17)!}$$

23. (c) Given, word "EQUATION"

Here, consonants—Q, T, N  
and Vowel—E, U, A, I, O

$$\therefore \text{Number of word} = {}^3C_3 \times 3! \times {}^3C_2 \times 3!$$

$$= 10 \times 6 \times 3 \times 6$$

$$= 1080$$

24. (c) According to the question,

Consider,  $x_1 + x_2 + x_3 + x_4 = 10$ , where  $x_i \geq 2$

$$\Rightarrow (x_1 - 2) + (x_2 - 2) + (x_3 - 2) + (x_4 - 2) = 2$$

$$\Rightarrow y_1 + y_2 + y_3 + y_4 = 2 \text{ where } y_i \geq 2,$$

(where,  $x_1 - 2 = y_1, x_2 - 2 = y_2, x_3 - 2 = y_3$  and  $x_4 - 2 = y_4$ )

$$\therefore \text{Number of ways} = {}^{2+4-1}C_{4-1} = {}^5C_3 = 10$$

25. (a) We have,

$$1! + 2! + 3! + 4! + 5! + \dots + 99!$$

Since unit digit of  $5!, 6!, 7!, \dots, 99!$  are zero.

$$\therefore 1! + 2! + 3! + 4! + 5! + \dots + 99!$$

$$= 1 + 2 + 6 + 24 = 33$$

$\therefore$  Unit digit = 3

26. (c) Given,

$$(012)M = (100) \quad \dots(i)$$

and

$$(345)M = (010) \quad \dots(ii)$$

$$\Rightarrow (6810)M = (020)$$

On subtracting Eq. (i) from Eq. (ii), we get

$$(6810)m - (012)M = (020) - (100)$$

$$\Rightarrow (678)M = (-120)$$

$$A = \begin{bmatrix} 1 & 0 & 0 \\ 0 & \cos t & \sin t \\ 0 & -\sin t & \cos t \end{bmatrix}$$

Since,  $\det(A - \lambda I_3) = 0$

$$\Rightarrow \begin{vmatrix} 1-\lambda & 0 & 0 \\ 0 & \cos t - \lambda & \sin t \\ 0 & -\sin t & \cos t - \lambda \end{vmatrix} = 0$$

$$\Rightarrow (1-\lambda) \{(\cos t - \lambda)^2 + (\sin t)^2\} = 0$$

$$\Rightarrow (1-\lambda) (\cos^2 t + \lambda^2 - 2\lambda \cos t + \sin^2 t) = 0$$

$$\Rightarrow (1-\lambda) (\lambda^2 - 2\lambda \cos t + 1) = 0$$

$$\Rightarrow \lambda^2 - 2\lambda \cos t + 1 - \lambda^3 + 2\lambda^2 \cos t - \lambda = 0$$

$$\Rightarrow -\lambda^3 + \lambda^2(1 + 2\cos t) - \lambda(1 + 2\cos t) + 1 = 0$$

$$\Rightarrow \lambda^3 - \lambda^2(1 + 2\cos t) + \lambda(1 + 2\cos t) - 1 = 0$$

$$\therefore \lambda_1 + \lambda_2 + \lambda_3 = (1 + 2\cos t)$$

$$\Rightarrow 1 + 2\cos t = \sqrt{2} + 1 \text{ (Given)}$$

$$\Rightarrow \cos t = \frac{1}{\sqrt{2}} \Rightarrow t = -\frac{\pi}{4}, \frac{\pi}{4}$$

28. (c) Given A and B be two non-singular skew symmetric matrices.

Such that  $AB = BA$

$$\Rightarrow A^T = -A \text{ and } B^T = -B \quad \dots(i)$$

Since matrices are non-singular  
 $\therefore$  order of these matrices are even.

Now,  $A^2 B^2 (A^T B)^{-1} (AB^{-1})^T$

$$= A^2 B^2 (-AB)^{-1} (AB^{-1})^T$$

$$= -A^2 B^2 (B^{-1} A^{-1}) (B^T)^{-1} A^T$$

$$= -A^2 (B^2 B^{-1}) A^{-1} (-B)^{-1} (-A)$$

$$= -A^2 B \cdot A^{-1} B^{-1} A$$

$$= -A^2 B(BA)^{-1} A$$

$$= -A^2 B(AB)^{-1} A \quad (\because AB = BA)$$

$$= -A^2 B B^{-1} A^{-1} A$$

$$= -A^2 (B B^{-1}) (A^{-1} A)$$

$$= -A^2$$

29. (d) We have,  $a_n = ar^{n-1}$

$$\Rightarrow \log a_n = \log(ar^{n-1})$$

$$\Rightarrow \log a_n = \log a + (n-1) \log r$$

Now,  $\begin{vmatrix} \log a_n & \log a_{n+1} & \log a_{n+2} \\ \log a_{n+3} & \log a_{n+4} & \log a_{n+5} \\ \log a_{n+6} & \log a_{n+7} & \log a_{n+8} \end{vmatrix}$

$$= \begin{vmatrix} \log a + (n-1) \log r & \log a + n \log r \\ \log a + (n+2) \log r & \log a + (n+3) \log r \\ \log a + (n+5) \log r & \log a + (n+6) \log r \\ \log a + (n+1) \log r \\ \log a + (n+4) \log r \\ \log a + (n+7) \log r \end{vmatrix}$$

On applying  $R_2 \rightarrow R_2 - R_1, R_3 \rightarrow R_3 - R_1$

$$\begin{vmatrix} \log a + (n-1) \log r & \log a + n \log r & \log a + (n+1) \log r \\ 3 \log r & 3 \log r & 3 \log r \\ 6 \log r & 6 \log r & 6 \log r \end{vmatrix}$$

= 0 (Since  $R_2$  and  $R_3$  are proportional)

**30.** (a) Given,  $(A \cap C) \cup (B \cap C') = \phi$   
 $\Rightarrow A \cap C = \phi$  ... (i)  
 and  $B \cap C' = \phi$  ... (ii)  
 From Eqs. (i) and (ii), we get  
 $A \cap B = \phi$

**31.** (b) Since,  $n(A) \neq n(T)$   
 and  $n(A) \neq n(U)$   
 $\therefore$  There does not exist bijective mapping between  $A$  and  $T, U$ .

**32.** (d) Even numbers on die are 2, 4, 6.  
 and odd numbers on die are 1, 3, 5.

$$\therefore P(\text{even}) = \frac{3}{6} = \frac{1}{2}$$

$$\text{and } P(\text{odd}) = \frac{3}{6} = \frac{1}{2}$$

According to the question,

$$P(A_{\text{wins}}) = \frac{1}{2} + \left(\frac{1}{2}\right)^4 \times \frac{1}{2} + \left(\frac{1}{2}\right)^8 \times \frac{1}{2} + \left(\frac{1}{2}\right)^{12} \times \frac{1}{2} + \dots \infty$$

$$= \frac{1}{2} + \left(\frac{1}{2}\right)^5 + \left(\frac{1}{2}\right)^9 + \left(\frac{1}{2}\right)^{13} + \dots \infty$$

$$= \frac{\frac{1}{2}}{1 - \left(\frac{1}{2}\right)^4} = \frac{\frac{1}{2}}{\frac{15}{16}} = \frac{1}{2} \times \frac{16}{15} = \frac{8}{15}$$

**33.** (a) We have,  
 Mean,  $np = 4$   
 and variance,  $npq = 2$   
 $\therefore \frac{npq}{np} = \frac{2}{4} = \frac{1}{2}$   
 $\Rightarrow q = \frac{1}{2} \therefore p = \frac{1}{2}$  and  $n = 8$

$$\therefore P(x=2) = {}^8C_2 \left(\frac{1}{2}\right)^2 \left(\frac{1}{2}\right)^6$$

$$= {}^8C_2 \left(\frac{1}{2}\right)^8$$

$$= \frac{8 \times 7}{2 \times 1} \times \frac{1}{256} = \frac{7}{64}$$

**34.** (b) Given,  
 $S_n = \cot^{-1} 2 + \cot^{-1} 8 + \cot^{-1} 18$   
 $+ \cot^{-1} 32 + \dots$  to  $n^{\text{th}}$  term.  
 $= \cot^{-1} 2 \times 1^2 + \cot^{-1} 2 \times 2^2 + \cot^{-1} 2 \times 3^2$   
 $+ \cot^{-1} 2 \times 4^2 + \dots$

$$\therefore n^{\text{th}} \text{ term} = \cot^{-1} 2n^2$$

$$\Rightarrow t_n = \tan^{-1} \left(\frac{1}{2n^2}\right)$$

$$= \tan^{-1} \left(\frac{(2n+1) - (2n-1)}{1 + (2n+1)(2n-1)}\right)$$

$$= \tan^{-1}(2n+1) - \tan^{-1}(2n-1)$$

$$\therefore S_n = \tan^{-1}(2n+1) - \tan^{-1}(1)$$

$$\therefore \lim_{n \rightarrow \infty} S_n = \tan^{-1}(\infty) - \tan^{-1}(1)$$

$$= \frac{\pi}{2} - \frac{\pi}{4} = \frac{\pi}{4}$$

**35.** (a) We have vertices of parallelogram  $O(0, 0)$ ,  
 $A(a \cos \theta, b \sin \theta)$  and  $B(a \cos \theta, -b \sin \theta)$

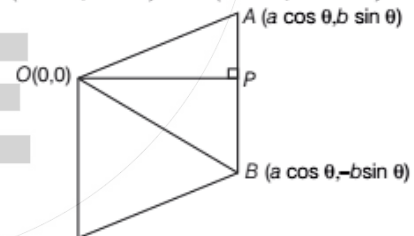

Here,  $OA = OB$   
 $\therefore$  Area of parallelogram =  $2 \times$  area of  $\Delta OAB$   
 $= 2 \times \left(\frac{1}{2} \times OP \times AB\right)$   
 $= 2 \times \frac{1}{2} \times a \cos \theta \times 2b \sin \theta$   
 $= 2 \times ab (\sin \theta \cos \theta)$   
 $= ab \sin 2\theta$   
 $\therefore$  Area will be maximum when  $\theta = \frac{\pi}{4}$   
 $\Rightarrow$  Maximum Area =  $ab$  when  $\theta = \frac{\pi}{4}$

36. (a) Let point  $B = (2p, 0)$

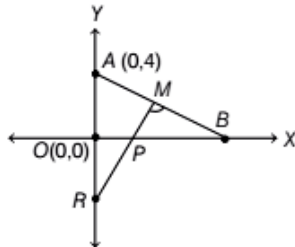

∴ Coordinates of  $M$  are  $(p, 2)$

Now, Slope of  $AB = \frac{4-0}{0-2p} = -\frac{2}{p}$

∴ Slope  $MR = \frac{p}{2}$

∴ Equations of  $MR = y - 2 = \frac{p}{2}(x - p)$

On putting  $x = 0$ , we get

$y - 2 = -\frac{p^2}{2} \Rightarrow y = 2 - \frac{p^2}{2}$

∴ Coordinates of  $R$  is  $(0, 2 - \frac{p^2}{2})$

∴ Coordinates of  $P$  is  $(\frac{p}{2}, \frac{2 - \frac{p^2}{2} + 2}{2})$

i.e.  $(\frac{p}{2}, 2 - \frac{p^2}{4})$

∴  $y = 2 - x^2 \Rightarrow y + x^2 = 2$

37. (b)

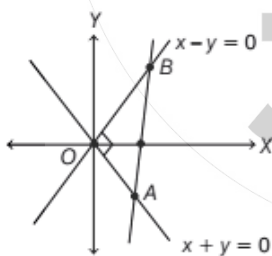

Let coordinates of  $A$  are  $(\alpha, -\alpha)$  and coordinates of  $B$  are  $(\beta, \beta)$

∴  $\beta + \alpha = 2h$  and  $\beta - \alpha = 2k$

Now, Area of  $\Delta AOB = \frac{1}{2} \times OA \times OB$

$= \frac{1}{2} \sqrt{2\alpha^2} \sqrt{2\beta^2} = |\alpha\beta| = c$

$\Rightarrow \alpha^2\beta^2 = c^2$

$\Rightarrow 16\alpha^2\beta^2 = 16c^2$

$\Rightarrow \{(\beta + \alpha)^2 - (\beta - \alpha)^2\} = 16c^2$

$\Rightarrow (4h^2 - 4k^2) = 16c^2$

$\Rightarrow h^2 - k^2 = c^2$

∴ Locus of the mid point  $P$  of  $MR$  is  $(x^2 - y^2) = c^2$

38. (a) Given equation of parabola

$6y = 2a^3x^2 + 3a^2x - 12a$

$\Rightarrow 6y + 12a = 2a\left(a^2x^2 + \frac{3}{2}ax\right)$

$= 2a\left(a^2x^2 + 2 \cdot \frac{3}{4}ax + \frac{9}{16}\right) - \frac{9}{8}a$

$\Rightarrow 6y + \frac{105}{8}a = 2a\left(ax + \frac{3}{4}\right)^2$

Let vertices are  $(h, k)$

∴  $h = \frac{-3}{4a}$  and  $k = \frac{-35a}{16}$

$hk = \frac{105}{64}$

∴ locus of the vertices is

$xy = \frac{105}{64}$

39. (b) Given, equation of ray of light  $x + \sqrt{3}y = \sqrt{3}$

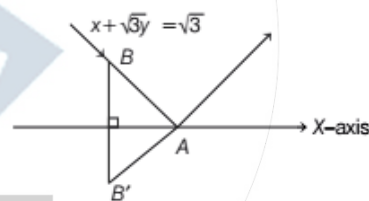

On putting  $y = 0$ , we get  $x = \sqrt{3}$

∴ Coordinates of  $A$  are  $(\sqrt{3}, 0)$

Now, let  $B(0, 1)$  then  $B' = (0, -1)$

∴ Equation of  $AB'$  is  $\frac{y-0}{0+1} = \frac{x-\sqrt{3}}{\sqrt{3}-0}$

$\Rightarrow \sqrt{3}y = x - \sqrt{3}$

40. (a)

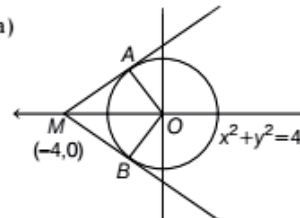

Given, equation of circle  $x^2 + y^2 = 4$

Centre =  $(0, 0)$  and radius = 2



$$\therefore MA = \sqrt{(4)^2 - (2)^2} = \sqrt{12} = 2\sqrt{3}$$

$$\begin{aligned} \therefore \text{Area of quadrilateral } MAOB &= 2 \times \text{area of } \Delta MAO \\ &= 2 \times \frac{1}{2} \times MA \times OA \\ &= 2\sqrt{3} \times 2 \\ &= 4\sqrt{3} \text{ sq. units.} \end{aligned}$$

41. (b) Given, equation of parabola  $y^2 = x$

We know that for  $y^2 = 4ax$

if we draw a normal from  $(h, 0)$  on it then condition for three normal is  $h > 2a$

$$\therefore d > \frac{1}{2}$$

42. (b)

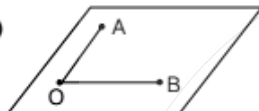

According to question the coordinates of A and B are  $(0, b, c)$  and  $(a, 0, c)$  respectively.

Now, perpendicular vector  $OA \times OB$

$$\begin{aligned} &= \begin{vmatrix} \hat{i} & \hat{j} & \hat{k} \\ 0 & b & c \\ a & 0 & c \end{vmatrix} \\ &= \hat{i}(bc - 0) - \hat{j}(0 - ac) + \hat{k}(0 - ab) \\ &= bc\hat{i} + ac\hat{j} - ab\hat{k} \end{aligned}$$

$\therefore$  Required equation of plane is  $bcx + acy - abz = 0$

43. (b) Given, equation of ellipse  $x^2 + 2y^2 = 4$

$$\Rightarrow \frac{x^2}{4} + \frac{y^2}{2} = 1 \quad \dots (i)$$

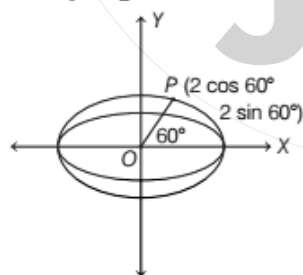

Now, equation of auxiliary circle is  $x^2 + y^2 = 4$

$\therefore$  Point on the auxiliary circle with eccentric angle  $60^\circ$  is  $P(2\cos 60^\circ, 2\sin 60^\circ)$

i.e.,  $P(1, \sqrt{3})$

44. (b) According to the question, we have.

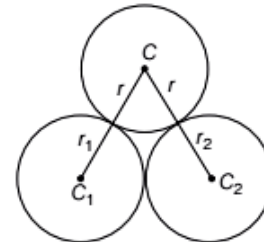

$$CC_1 = r + r_1$$

and

$$CC_2 = r + r_2$$

$$\therefore CC_2 - CC_1 = (r + r_2) - (r + r_1) = r_2 - r_1$$

$\Rightarrow$  Locus of centre is Hyperbola.

45. (c) Let direction cosines of line is  $(l, l, l)$ .

$$\therefore l^2 + l^2 + l^2 = 1$$

$$\Rightarrow 3l^2 = 1 \Rightarrow l = \frac{1}{\sqrt{3}}$$

$\therefore$  Direction cosines of line is  $\left(\frac{1}{\sqrt{3}}, \frac{1}{\sqrt{3}}, \frac{1}{\sqrt{3}}\right)$

Now, equation of a line passing through  $P(2, -1, 2)$

$$\frac{x-2}{1/\sqrt{3}} = \frac{y+1}{1/\sqrt{3}} = \frac{z-2}{1/\sqrt{3}} = k \quad \dots (i)$$

$$\Rightarrow x = k + 2, y = k - 1 \text{ and } z = k + 2$$

Since line (i) meets the plane

$$2x + y + z = 9 \text{ at } Q$$

$$\therefore 2(k+2) + (k-1) + (k+2) = 9$$

$$\Rightarrow 2k + 4 + k - 1 + k + 2 = 9$$

$$\Rightarrow 4k + 5 = 9$$

$$\Rightarrow 4k = 4 \Rightarrow k = 1$$

$\therefore$  Coordinates of Q are  $(3, 0, 3)$

$$\begin{aligned} \therefore PQ &= \sqrt{(3-2)^2 + (0+1)^2 + (3-2)^2} \\ &= \sqrt{1+1+1} = \sqrt{3} \text{ units.} \end{aligned}$$

46. (b) Given,  $y = \sin^{-1} \left\{ \frac{5x + 12\sqrt{1-x^2}}{13} \right\}$

$$= \sin^{-1} \left\{ \frac{5x}{13} + \frac{12\sqrt{1-x^2}}{13} \right\}$$

Let  $\sin\theta_1 = \frac{5}{13}$  and  $\cos\theta_2 = x$

$$\therefore y = \sin^{-1}(\sin\theta_1 \cdot \cos\theta_2 + \cos\theta_1 \cdot \sin\theta_2)$$

$$= \sin^{-1}\{\sin(\theta_1 + \theta_2)\}$$

$$= \theta_1 + \theta_2 = \sin^{-1} \frac{5}{13} + \cos^{-1} x$$

$$\Rightarrow y_1 = -\frac{1}{\sqrt{1-x^2}}$$

and

$$y_2 = \frac{-x}{(1-x^2)\sqrt{1-x^2}}$$

$$\Rightarrow y_2(1-x^2) = xy_1$$

$$\Rightarrow y_2(1-x^2) - xy_1 = 0$$

$\therefore a = 1, b = -1$   
 $\therefore (a, b) = (1, -1)$

**47.** (c) Given,  $2f(x) + 3f(-x) = 15 - 4x$  ... (i)

On replacing  $x$  by  $-x$  in Eq. (i), we get

$$2f(-x) + 3f(x) = 15 + 4x$$
 ... (ii)

On solving Eqs. (i) and (ii), we get

$$f(x) = 4x + 3$$

$$\therefore f(2) = 4 \times 2 + 3 = 11$$

**48.** (c) Given,  $f_1(x) = x, f_2(x) = 2 + \log_e x$

Now, Let  $h(x) = f_2(x) - f_1(x)$

$$= (2 + \log_e x) - x$$

$$= 2 + \log_e x - x$$

Here,  $h(0^+) < 0, h(1) > 0, h(e) > 0$  and  $h(e^2) < 0$  and value of  $h(x)$  for all  $x \geq e^2$  is negative.

$\therefore h(x) = 0$  has two roots is  $(0, 1)$  and  $(e, e^2)$

**49.** (c) Given equation,  $6^x + 8^x = 10^x$

$$\Rightarrow \left(\frac{6}{10}\right)^x + \left(\frac{8}{10}\right)^x = 1$$

$$\Rightarrow \left(\frac{3}{5}\right)^x + \left(\frac{4}{5}\right)^x = 1$$

Let  $\frac{3}{5} = \sin\theta \Rightarrow \frac{4}{5} = \cos\theta$

$$\therefore (\sin\theta)^x + (\cos\theta)^x = 1$$

it is possible only  $x = 2$

$\therefore$  given equation has exactly one real root.

**50.** (b) We have,  $f : D \rightarrow R$  where  $D = [0, 1] \cup [2, 4]$

$$f(x) = \begin{cases} x, & \text{if } x \in [0, 1] \\ 4-x, & \text{if } x \in [2, 4] \end{cases}$$

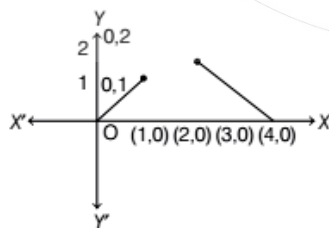

Clearly  $f(x)$  is increasing in  $[0, 1]$  and decreasing in  $[2, 4]$

$\therefore f(x)$  is neither continuous and nor differentiable in  $D$ .

$\therefore$  Rolles theorem is not applicable to  $f$  in  $D$

**51.** (b)  $f(x)$  be a continuous periodic function with period  $T$

Given,  $I = \int_a^{a+T} f(x) dx$

$$I = \int_0^T f(x) dx$$

Hence,  $I$  does not depend on ' $a$ '.

**52.** (c) We have,  $b = \int_0^1 \frac{e^t}{t+1} dt$

Let  $I = \int_{a-1}^a \frac{e^{-t}}{t-a-1} dt$

$$I = \int_{a-1}^a \frac{e^{-(a+a-1-t)}}{a+a-1-t-a-1} dt$$

$$\left[ \because \int_a^b f(x) dx = \int_a^b f(a+b-x) dx \right]$$

$$I = \int_{a-1}^a \frac{e^{t-2a+1}}{a-2-t} dt$$

put  $t - (a - 1) = x \Rightarrow dt = dx$   
 when  $t = a, x = 1$  and  $t = a - 1 \Rightarrow x = 0$

$$\therefore I = \int_0^1 \frac{e^{x+a-1-2a+1}}{a-2-x-a+1} dx$$

$$\Rightarrow I = \int_0^1 \frac{e^x \cdot e^{-a}}{-(x+1)} dx$$

$$\Rightarrow I = -e^{-a} \int_0^1 \frac{e^x}{x+1} dx$$

$$\Rightarrow I = -e^{-a}(b) \quad \left[ \because \int_0^1 \frac{e^t}{t+1} dt = b \right]$$

$$\Rightarrow I = -be^{-a}$$

**53.** (a) We have,

$$f(x) = \log_e(1 + e^{10x}) - \tan^{-1}(e^{5x})$$

$$\Rightarrow f'(x) = \frac{10e^{10x}}{1 + e^{10x}} - \frac{5e^{5x}}{1 + e^{10x}}$$

$$\Rightarrow f'(x) = \frac{10e^{10x} - 5e^{5x}}{1 + e^{10x}}$$

$$\Rightarrow f'(0) = \frac{10-5}{1+1} = \frac{5}{2}$$

We know that,

$$f(x + \Delta x) - f(x) = f'(x) dx$$

$$\Rightarrow f(x + \Delta x) - f(x) = \frac{5}{2} \times 0.2 \quad [\because dx = 0.2]$$

$$\Rightarrow \Delta f(x) = 0.5$$

$$= 5 \times \frac{2}{3} [y^{3/2}]_0^2$$

$$= \frac{10}{3} [2^{3/2} - 0]$$

$$= \frac{10}{3} \times 2\sqrt{2}$$

$$= \frac{20}{3} \sqrt{2} \text{sq unit.}$$

54. (b) We have,

$$f(x) = 1 + \sqrt{x}$$

$$f(c) = 1 + \sqrt{c}$$

$$\Rightarrow c = 1 + \sqrt{c} \quad [\because f(c) = c]$$

$$\Rightarrow (c-1)^2 = (\sqrt{c})^2$$

$$\Rightarrow c^2 - 2c + 1 = c$$

$$\Rightarrow c^2 - 3c + 1 = 0$$

$$\Rightarrow c = \frac{3 \pm \sqrt{5}}{2}$$

\(\therefore f\) has unique fixed point in \([1, \infty)\)

55. (c) Let  $L = \lim_{x \rightarrow \infty} \left( \frac{3x-1}{3x+1} \right)^{4x}$

$$L = e^{\lim_{x \rightarrow \infty} \left( \frac{3x-1}{3x+1} - 1 \right) 4x}$$

$$L = e^{\lim_{x \rightarrow \infty} \left( \frac{3x-1-3x-1}{3x+1} \right) 4x}$$

$$L = e^{\lim_{x \rightarrow \infty} \frac{-2 \times 4}{3 + \frac{1}{x}}}$$

$$L = e^{-8/3}$$

56. (a) Given curve,  $y = 4x^2$ ,  $y = \frac{x^2}{9}$  and  $y = 2$

Graph of given curve

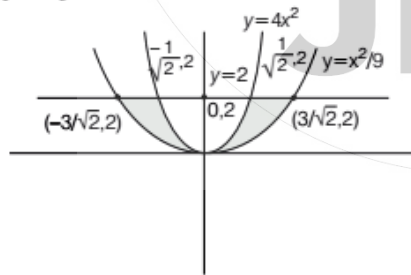

Area of shaded region

$$= 2 \int_0^2 \left( 3\sqrt{y} - \frac{\sqrt{y}}{2} \right) dy$$

$$= 2 \int_2^0 \frac{5\sqrt{y}}{2} dy$$

57. (c) We have,

$$a(\alpha \times \beta) + b(\beta \times \gamma) + c(\gamma \times \alpha) = 0$$

Clearly  $a(\alpha \times \beta)$ ,  $(\beta \times \gamma)$  and  $(\gamma \times \alpha)$  are coplanar vector. \(\therefore \alpha, \beta\) and  $\gamma\) are also coplanar$

58. (b) Given equation

$$y^2 = 2x^3$$

$$\Rightarrow 2y \frac{dy}{dx} = 6x^2$$

$$\Rightarrow \frac{dy}{dx} = \frac{3x^2}{y}$$

$$\Rightarrow \left( \frac{dy}{dx} \right)_{(h,k)} = \frac{3h^2}{k}$$

Slope of tangent is perpendicular to line  $4x = 3y$

$$\therefore \left( \frac{3h^2}{k} \right) \left( \frac{4}{3} \right) = -1$$

$$\Rightarrow 4h^2 = -k \quad \dots (i)$$

$$\text{and } k^2 = 2h^3 \quad \dots (ii)$$

From Eqs. (i) and (ii)

$$(4h^2)^2 = 2h^3$$

$$\Rightarrow 16h^4 = 2h^3$$

$$\Rightarrow h = \frac{1}{8}$$

$$\therefore k = -4 \left( \frac{1}{8} \right)^2$$

$$\Rightarrow k = -4 \times \frac{1}{64} = \frac{-1}{16}$$

$$\therefore (h, k) = \left( \frac{1}{8}, \frac{-1}{16} \right) \text{ only}$$

59. (d) Given,  $(bc + ca + ab)^6$

$$\text{General term} = \frac{6!}{p!q!r!} (bc)^p (ca)^q (ab)^r$$

$$= \frac{6!}{p!q!r!} (a)^{q+r} (b)^{p+r} (c)^{p+q}$$

Coefficient of  $a^3b^4c^5$  in the expansion  $(bc + ca + ab)^6$

$$\therefore q + r = 3, p + r = 4, p + q = 5$$

$$= 2p + q + r = 12$$

$$= p + q + r = 6$$

$$\therefore p = 3, q = 2, r = 1$$

$$\therefore \text{Coefficient of } a^3 b^4 c^5 \text{ is } \frac{6!}{3!2!1!} = 3 \left( \frac{6!}{3!3!} \right)$$

60. (c) Given  $a, b, c$  are in G.P and  $\log\left(\frac{5c}{2a}\right), \log\left(\frac{7b}{5c}\right)$ .

$$\log\left(\frac{2a}{7b}\right) \text{ and A.P}$$

$$\therefore b^2 = ac$$

$$\text{and } 2\log\left(\frac{7b}{5c}\right) = \log\left(\frac{5c}{2a}\right) + \log\left(\frac{2a}{7b}\right)$$

$$\Rightarrow \frac{49b^2}{25c^2} = \frac{5c}{7b}$$

$$\Rightarrow (7b)^3 = (5c)^3$$

$$\Rightarrow 7b = 5c \Rightarrow c = \frac{7}{5}b$$

$$\text{and } b^2 = ac$$

$$\Rightarrow b^2 = a\left(\frac{7}{5}b\right)$$

$$\Rightarrow b = \frac{7}{5}a$$

$$\text{Sides are } \frac{5b}{7}, b, \frac{7b}{5}$$

$\therefore a, b, c$  are the length of the sides of scalene triangle.

61. (b) We have,

$$\begin{vmatrix} a^2 + 10 & ab & ac \\ ab & b^2 + 10 & bc \\ ac & bc & c^2 + 10 \end{vmatrix}$$

$$= \frac{1}{abc} \begin{vmatrix} a(a^2 + 10) & ab^2 & ac^2 \\ a^2b & b(b^2 + 10) & bc^2 \\ a^2c & b^2c & c(c^2 + 10) \end{vmatrix}$$

Taking common  $a, b, c$  from  $R_1, R_2$  and  $R_3$  respectively

$$= \frac{abc}{abc} \begin{vmatrix} a^2 + 10 & b^2 & c^2 \\ a^2 & b^2 + 10 & c^2 \\ a^2 & b^2 & c^2 + 10 \end{vmatrix}$$

Applying  $C_1 \rightarrow C_1 + C_2 + C_3$ , we get

$$= \begin{vmatrix} a^2 + b^2 + c^2 + 10 & b^2 & c^2 \\ a^2 + b^2 + c^2 + 10 & b^2 + 10 & c^2 \\ a^2 + b^2 + c^2 + 10 & b^2 & c^2 + 10 \end{vmatrix}$$

$$= (a^2 + b^2 + c^2 + 10) \begin{vmatrix} 1 & b^2 & c^2 \\ 1 & b^2 + 10 & c^2 \\ 1 & b^2 & c^2 + 10 \end{vmatrix}$$

$$R_2 \rightarrow R_2 - R_1 \text{ and } R_3 \rightarrow R_3 - R_1$$

$$= (a^2 + b^2 + c^2 + 10) \begin{vmatrix} 1 & b^2 & c^2 \\ 0 & 10 & 0 \\ 0 & 0 & 10 \end{vmatrix}$$

$$= (a^2 + b^2 + c^2 + 10) (100)$$

$\therefore$  If is divisible by 100.

62. (b) We have,

$$S = \{(x, y) : y = x + 1, 0 < x < 2\}$$

For reflexive  $(x, x) \in S$

$$x = x + 1 \notin S$$

$\therefore S$  is not reflexive

$\therefore S$  is not equivalence relation

$$T = \{(x, y) : x - y \text{ is an integer}\}$$

For reflexive  $(x, x) \in T$

$$x = x - x = 0 \in R$$

$T$  is reflexive

For symmetric

$$(x, y) = x - y \text{ is an integer}$$

$$(y, x) = y - x \text{ is also integer}$$

$\therefore T$  is symmetric

For Transitive

$$(x, y) \in T, (y, z) \in T \Rightarrow (x, z) \in T$$

$$(x, y) = x - y \text{ is an integer}$$

$$(y, z) = y - z \text{ is also integer}$$

$$\therefore (x - y) + (y - z) = x - z \text{ is an integer}$$

$$\therefore (x, z) \in T$$

Hence,  $T$  is an equivalence relation.

63. (d) Given plane,

$$P_1 = lx + my = 0 \text{ and } P_2 = z = 0$$

Plane through common line of  $P_1$  and  $P_2$

$$\therefore P_3 = lx + my + nz = 0$$

angle between  $P_1$  and  $P_3 = \alpha$

$$\therefore \cos \alpha = \frac{l^2 + m^2}{\sqrt{l^2 + m^2 + n^2} \sqrt{l^2 + m^2}}$$

$$\Rightarrow \cos \alpha = \frac{\sqrt{l^2 + m^2}}{\sqrt{l^2 + m^2 + n^2}}$$

$$\Rightarrow \cos^2 \alpha = \frac{l^2 + m^2}{l^2 + m^2 + n^2}$$

$$\Rightarrow \sec^2 \alpha = \frac{l^2 + m^2 + n^2}{l^2 + m^2} = 1 + \frac{n^2}{l^2 + m^2}$$

$$\Rightarrow (\sec^2 \alpha - 1)(l^2 + m^2) = n^2$$

$$\Rightarrow n^2 = \tan^2 \alpha (l^2 + m^2)$$

$$= n = \pm \sqrt{l^2 + m^2} \tan \alpha$$

∴ Equation becomes

$$lx + my \pm z \tan \alpha \sqrt{l^2 + m^2} = 0$$

**64.** (c) Given ellipse

$$x^2 + 2y^2 - 6x - 12y + 20 = 0$$

and

$$2x^2 + y^2 - 10x - 6y + 15 = 0$$

The point of intersection of the given ellipse is

$$(x^2 + 2y^2 - 6x - 12y + 20) +$$

$$\lambda(2x^2 + y^2 - 10x - 6y + 15) = 0$$

$$(1 + 2\lambda)x^2 + (2 + \lambda)y^2 - (6 + 10\lambda)x - (12 + 6\lambda)y + 20 + 5\lambda = 0$$

The points lie on circle

∴ Equation becomes circle

$$\therefore 1 + 2\lambda = 2 + \lambda \Rightarrow \lambda = 1$$

∴ Equation of circle is

$$3x^2 + 3y^2 - 16x - 18y + 35 = 0$$

∴ Centre of circle is  $(\frac{8}{3}, 3)$

**65.** (a) We have,  $I = \int_{\pi/4}^{\pi/3} \frac{\sin x}{x} dx$

Let  $f(x) = \frac{\sin x}{x}$

$f(x)$  is decreasing functions

$$\Rightarrow f(\pi/3) < f(x) < f(\pi/4)$$

$$\Rightarrow \frac{3\sqrt{3}}{2\pi} < f(x) < \frac{2\sqrt{2}}{\pi}$$

$$\Rightarrow \frac{3\sqrt{3}}{2\pi} \int_{\pi/4}^{\pi/3} dx < I < \frac{2\sqrt{2}}{\pi} \int_{\pi/4}^{\pi/3} dx$$

$$\Rightarrow \frac{3\sqrt{3}}{2\pi} \left(\frac{\pi}{3} - \frac{\pi}{4}\right) < I < \frac{2\sqrt{2}}{\pi} (\pi/3 - \pi/4)$$

$$\Rightarrow \frac{\sqrt{3}}{8} < I < \frac{\sqrt{2}}{6}$$

**66.** (b, c) have  $|z + i| - |z - 1| = |z| - 2$

$|z| - 2 \Rightarrow |z| = 2$  represent a circle.

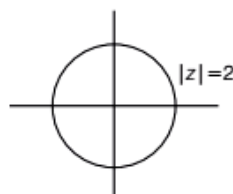

$$|z + i| - |z - 1| = 0$$

$$\Rightarrow |z + i| = |z - 1|$$

$$x^2 + (y + 1)^2 = (x - 1)^2 + y^2$$

$$\Rightarrow x^2 + y^2 + 2y + 1 = x^2 - 2x + 1 + y^2$$

$$= y = -x \quad \dots(i)$$

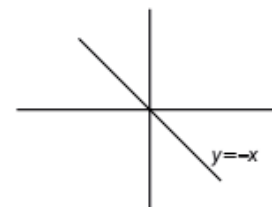

∴  $|z| = 2 \Rightarrow x^2 + y^2 = 4$  ∴(ii)

From Eqs. (i) and (ii)

$$x^2 + x^2 = 4$$

$$\Rightarrow 2x^2 = 4 \Rightarrow x = \pm \sqrt{2}$$

and

$$y = \mp \sqrt{2}$$

∴

$$z = x + iy$$

$$z = \pm \sqrt{2} \mp \sqrt{2}i$$

$$z = \pm \sqrt{2}(1 \mp i)$$

$$z = \sqrt{2}(1 - i)$$

$$z = \sqrt{2}(-1 + i)$$

**67.** (d) We have,

$$\begin{vmatrix} x & 3x + 2 & 2x - 1 \\ 2x - 1 & 4x & 3x + 1 \\ 7x - 2 & 17x + 6 & 12x - 1 \end{vmatrix} = 0$$

$R_3 \rightarrow R_3 - 3R_1 - 2R_2$ , we get

$$\begin{vmatrix} x & 3x + 2 & 2x - 1 \\ 2x - 1 & 4x & 3x + 1 \\ 0 & 0 & 0 \end{vmatrix} = 0$$

∴ infinite value of  $x$  is possible.

**68.** (b) We have

$$7^{7^{7^{\dots}}} \text{ (22 time 7)}$$

$$\Rightarrow 7^{7^7} \text{ is an odd number}$$

$$\therefore 7^{(2m+1)} = 7^{2m} \times 7$$

$$= (7^2)^m \times 7$$

$$= (49)^m \times 7$$

$$= (48 + 1)^m \times 7$$

$$= 7(1 + 48k)$$

$$= 7 + (48 \times 7) k$$

∴ remainder = 7

69. (c, d) (a)  $I_1 = \int_{-2}^2 \frac{dx}{4+x^2}$

It is possible to put  $x = \tan t$

Option (a) is incorrect.

(b)  $I_2 = \int_0^1 \sqrt{x^2+1} dx$

It is possible to put  $x = \tan t$

∴ Option (b) is also incorrect

Hence, option (c) and (d) are correct.

70. (a, c) Let equation of plane be

$$\frac{x}{a} + \frac{y}{b} + \frac{z}{c} = 1$$

$$\text{Centroid} = \left( \frac{a}{3}, \frac{b}{3}, \frac{c}{3} \right)$$

$$\therefore \frac{a}{3} = 1, \frac{b}{3} = r, \frac{c}{3} = r^2$$

$$\Rightarrow a = 3, b = 3r, c = 3r^2$$

Equation of plane be

$$\frac{x}{3} + \frac{y}{3r} + \frac{z}{3r^2} = 1$$

Now plane is passes through (5, 5, -12)

$$\therefore \frac{5}{3} + \frac{5}{3r} - \frac{12}{3r^2} = 1$$

$$\Rightarrow 5r^2 + 5r - 12 = 3r^2$$

$$\Rightarrow 2r^2 + 5r - 12 = 0$$

$$\Rightarrow 2r^2 + 8r - 3r - 12 = 0$$

$$= (2r - 3)(r + 4) = 0$$

$$\Rightarrow r = 3/2, -4$$

71. (a) Let the equation of circle is

$$(x - \alpha)^2 + (y - \beta)^2 = r^2$$

$$\therefore x = \alpha + r \cos \theta$$

$$y = \beta + r \sin \theta$$

$$\therefore P \equiv (\alpha + r \cos \theta, \beta + r \sin \theta)$$

$$\theta = (a, b)$$

Let  $R = (h, k)$

$$\therefore h = \frac{\alpha + r \cos \theta}{2}, k = \frac{\beta + r \sin \theta}{2}$$

$$r \cos \theta = 2h - \alpha \text{ and } r \sin \theta = 2k - \beta$$

$$\therefore r^2(\cos^2 \theta + \sin^2 \theta) = (2h - \alpha)^2 + (2k - \beta)^2$$

$$= \left( h - \frac{\alpha}{2} \right)^2 + \left( k - \frac{\beta}{2} \right)^2 = \left( \frac{r}{2} \right)^2$$

$$\Rightarrow \text{Locus of } R \text{ is } \left( x - \frac{\alpha}{2} \right)^2 + \left( y - \frac{\beta}{2} \right)^2 = \frac{r^2}{4}$$

Which represents a circle the locus of  $R$  is circle.

72. (a) Let  $I = \lim_{n \rightarrow \infty} \left\{ \frac{\sqrt{n}}{\sqrt{n^3}} + \frac{\sqrt{n}}{\sqrt{(n+4)^3}} + \frac{\sqrt{n}}{\sqrt{(n+8)^3}} \right.$

$$\left. + \dots + \frac{\sqrt{n}}{\sqrt{[n+4(n-1)]^3}} \right\}$$

$$\Rightarrow I = \lim_{n \rightarrow \infty} \sum_{r=0}^{n-1} \frac{\sqrt{n}}{\sqrt{(n+4r)^3}}$$

$$\Rightarrow I = \lim_{n \rightarrow \infty} \frac{1}{n} \sum_{r=0}^{n-1} \frac{n\sqrt{n}}{\sqrt{(n+4r)^3}}$$

$$\Rightarrow I = \lim_{n \rightarrow \infty} \frac{1}{n} \sum_{r=0}^{n-1} \frac{1}{\sqrt{\left(1 + \frac{4r}{n}\right)^{3/2}}}$$

$$\Rightarrow I = \int_0^1 \frac{dx}{(1+4x)^{3/2}}$$

$$\Rightarrow I = \left[ \frac{(1+4x)^{-3/2+1}}{4(-3/2+1)} \right]_0^1$$

$$\Rightarrow I = \frac{-1}{2} [(1+4x)^{-1/2}]_0^1$$

$$\Rightarrow I = \frac{-1}{2} [5^{-1/2} - 1]$$

$$\Rightarrow I = \frac{-1}{2} \left[ \frac{1}{\sqrt{5}} - 1 \right]$$

$$\Rightarrow I = \frac{-1}{2} \left[ \frac{1 - \sqrt{5}}{\sqrt{5}} \right]$$

$$\Rightarrow I = \frac{\sqrt{5}-1}{2\sqrt{5}} = \frac{\sqrt{5}(\sqrt{5}-1)}{10} = \frac{5-\sqrt{5}}{10}$$

73. (a, d) We have,  $f(x) = \begin{cases} 0, & \text{if } -1 \leq x < 0 \\ 1, & \text{if } x = 0 \\ 2, & \text{if } 0 < x \leq 1 \end{cases}$

$$F(x) = \int_{-1}^x f(t) dt$$

$$F(x) = \int_{-1}^0 0 dt + \int_0^1 2 dt$$

$$F(x) = \begin{cases} 0, & -1 \leq x \leq 0 \\ 2x, & 0 < x \leq 1 \end{cases}$$

Graph of  $i(x)$  is

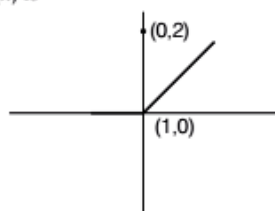

Clearly  $F(x)$  is continuous in  $[-1, 1]$

$F'(x)$  does not exist at  $x = 0$

**74.** (b, c) We have,

$$f(x) = \tan^{-1} x - \frac{1}{2} \log x \text{ on } \left[ \frac{1}{\sqrt{3}}, \sqrt{3} \right]$$

$$f'(x) = \frac{1}{1+x^2} - \frac{1}{2x}$$

$$f'(x) = \frac{2x-1-x^2}{2x(1+x^2)}$$

$$f'(x) = \frac{-(x^2-2x+1)}{2x(1+x^2)}$$

$$f'(x) = \frac{-(x-1)^2}{2x(1+x^2)}$$

$f'(x)$  is decreasing function  $\forall x > 0$

$$f_{\max} \text{ at } x = \frac{1}{\sqrt{3}} \text{ and } f_{\min} \text{ at } x = \sqrt{3}$$

$$\therefore f\left(\frac{1}{\sqrt{3}}\right) = \tan^{-1} \frac{1}{\sqrt{3}} - \frac{1}{2} \log \frac{1}{\sqrt{3}}$$

$$= \frac{\pi}{6} + \frac{1}{4} \log 3$$

$$f(\sqrt{3}) = \tan^{-1} \sqrt{3} - \frac{1}{2} \log \sqrt{3}$$

$$= \frac{\pi}{3} - \frac{1}{4} \log 3$$

$$\therefore f_{\max} = \frac{\pi}{6} + \frac{1}{4} \log 3$$

$$f_{\min} = \frac{\pi}{3} - \frac{1}{4} \log 3$$

**75.** (d) We have,  $f$  and  $g$  be periodic function with periods  $T_1$  and  $T_2$  respectively  
 $f + g$  is periodic if  $T_1 = T_2$

JEE