

CONTENTS**FUNCTIONS**

THEORY & ILLUSTRATION	Page – 01
EXERCISE (O-1)	Page – 33
EXERCISE (O-2)	Page – 38
EXERCISE (S-1)	Page – 43
EXERCISE (S-2)	Page – 46
EXERCISE (JM)	Page – 48
EXERCISE (JA)	Page – 49

INVERSE TRIGONOMETRIC FUNCTIONS

THEORY & ILLUSTRATION	Page – 50
EXERCISE (O-1)	Page – 70
EXERCISE (O-2)	Page – 72
EXERCISE (S-1)	Page – 73
EXERCISE (S-2)	Page – 75
EXERCISE (JM)	Page – 76
EXERCISE (JA)	Page – 77
ANSWER KEY	Page – 79

JEE (Advanced) Syllabus :

Real valued functions of a real variable, into, onto and one-to-one functions, sum, difference, product and quotient of two functions, composite functions, absolute value, polynomial, rational, trigonometric, exponential and logarithmic functions. Inverse trigonometric functions (principal value only).

JEE (Main) Syllabus :

Real valued functions, algebra of functions, polynomials, rational, trigonometric, logarithmic and exponential functions, inverse functions. Graphs of simple functions. Oneone, into and onto functions, composition of functions.

Inverse trigonometrical functions and their properties.

FUNCTION

1. CARTESIAN PRODUCT OF TWO SETS :

Given two non-empty sets A and B. The cartesian product $A \times B$ is the set of all ordered pairs of the form (a, b) where the first entry comes from set A & second comes from set B.

$$A \times B = \{(a, b) \mid a \in A, b \in B\}$$

e.g. $A = \{1, 2, 3\}$ $B = \{p, q\}$

$$A \times B = \{(1, p), (1, q), (2, p), (2, q), (3, p), (3, q)\}$$

Note :

- (i) If either A or B is the null set, then $A \times B$ will also be empty set, i.e. $A \times B = \phi$
- (ii) If $n(A) = p, n(B) = q$, then $n(A \times B) = pq$, where $n(X)$ denotes the number of elements in set X.
- (iii) A **Relation** R from set A to B is any subset of $A \times B$. If $A R B$ & $(a, b) \in R$ then b is image of a under R and a is preimage of b under R.

Note : If $n(A) = m, n(B) = n$, then number of relations defined from set A to B are $2^{mn} - 1$.

2. FUNCTION :

A relation R from set A to set B is called a function if each element of A is uniquely associated with some element of B. It is denoted by the symbol :

$$f : A \rightarrow B \text{ or } A \xrightarrow{f} B$$

which reads 'f' is a function from A to B 'or' f maps A to B,

If an element $a \in A$ is associated with an element $b \in B$, then b is called 'the f image of a' or 'image of a under f' or 'the value of the function f at a'. Also a is called the 'pre-image of b' or 'argument of b under the function f'. We write it as

$$b = f(a) \text{ or } f : a \rightarrow b \text{ or } f : (a, b)$$

Thus a function 'f' from set A to set B is subset of $A \times B$ in which each a belonging to A appears in one and only one ordered pair belonging to f.

Representation of Funtion :

(a) **Ordered pair** : Every function from $A \rightarrow B$ satisfies the following conditions :

$$(i) f \subset A \times B \quad (ii) \forall a \in A \text{ there exist } b \in B \text{ and } (iii) (a, b) \in f \ \& \ (a, c) \in f \Rightarrow b = c$$

(b) **Formula based (uniformly/nonuniformly) :**

(i) $f : \mathbb{R} \rightarrow \mathbb{R}, y = f(x) = 4x, f(x) = x^2$ (uniformly defined)

(ii) $f(x) = \begin{cases} x+1 & -1 \leq x < 4 \\ -x & 4 \leq x < 7 \end{cases}$ (non-uniformly defined)

(iii) $f(x) = \begin{cases} x^2 & x \geq 0 \\ -x-1 & x < 0 \end{cases}$ (non-uniformly defined)

(c) **Graphical representation :**

If a vertical line cuts a given graph at more than one point then it can not be the graph of a function.

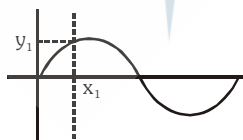

Graph (1)

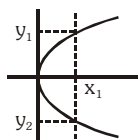

Graph (2)

Graph(1) represent a function but graph(2) does not represent a function.

Every function is a relation but every relation is not necessarily a function.

3. DOMAIN, CO-DOMAIN & RANGE OF A FUNCTION :

Let $f : A \rightarrow B$, then the set A is known as the domain of f & the set B is known as co-domain of f . The set of f images of all the elements of A is known as the range of f .

Domain of $f = \{a \mid a \in A, (a, f(a)) \in f\}$

Range of $f = \{f(a) \mid a \in A, f(a) \in B\}$

- (a) If only the rule of function is given then the domain of the function is the set of those real numbers, where function is defined.
- (b) For a continuous function, the interval from minimum to maximum value of a function gives the range
- (c) It should be noted that range is a subset of co-domain.

Note :

- (i) The complete set of all positive real numbers is denoted by R^+ .
- (ii) The complete set of all negative real numbers is denoted by R^- .
- (iii) The complete set of all real numbers other than zero is denoted by R_0 .
- (iv) The complete set of all integers is denoted by Z .

Illustration 1 : Find the domain of following functions :

(i) $y = \sqrt{5-2x}$ (ii) $y = \frac{1}{\sqrt{x-|x|}}$

Solution : (i) $5 - 2x \geq 0 \Rightarrow x \leq \frac{5}{2} \therefore$ Domain is $(-\infty, 5/2]$

(ii) $x - |x| > 0 \Rightarrow |x| < x \Rightarrow x$ cannot take any real values \therefore Domain is ϕ

Illustration 2 : Find the range of following functions :

(i) $f(x) = \log_{\sqrt{2}}((x-1)^2 + 4)$ (ii) $f(x) = 3 - \cos x$

Solution : (i) $f(x) = \log_{\sqrt{2}}((x-1)^2 + 4)$
 $4 \leq (x-1)^2 + 4 < \infty$
 $\Rightarrow \log_{\sqrt{2}} 4 \leq \log_{\sqrt{2}}((x-1)^2 + 4) < \infty$
 $\Rightarrow 4 \leq \log_{\sqrt{2}}((x-1)^2 + 4) < \infty$
 \therefore Range of $f(x) = [4, \infty)$

(ii) $f(x) = 3 - \cos x$
 $-1 \leq \cos x \leq 1$
 $2 \leq 3 - \cos x \leq 4$
 \therefore Range of $f(x) = [2, 4]$

Do yourself - 1 :

(i) Find the domain of following functions :

(a) $y = 1 - \log_{10} x$ (b) $y = \frac{1}{\sqrt{x^2 - 4x}}$

(ii) Find the range of the following function :

(a) $\log_4 \left| x + \frac{1}{x} \right|$ (b) $f(x) = \sin(3x^2 + 1)$

(c) $f(x) = 2 \sin \left(2x + \frac{\pi}{4} \right)$ (d) $f(x) = \cos \left(2x + \frac{\pi}{4} \right)$

4. IMPORTANT TYPES OF FUNCTIONS :

(a) Polynomial Function :

If a function f is defined by $f(x) = a_0x^n + a_1x^{n-1} + a_2x^{n-2} + \dots + a_{n-1}x + a_n$ where n is a non negative integer and $a_0, a_1, a_2, \dots, a_n$ are real numbers and $a_0 \neq 0$, then f is called a polynomial function of degree n . If n is odd, then polynomial is of odd degree, if n is even, then polynomial is of even degree.

Note :

- (i) Range of odd degree polynomial is always R .
- (ii) Range of even degree polynomial is never R .
- (iii) A polynomial of degree one with no constant term is called an odd linear function.
i.e. $f(x) = ax, a \neq 0$
- (iv) $f(x) = ax + b, a \neq 0$ is a linear polynomial
- (v) $f(x) = c$ is non linear polynomial (its degree is zero)
- (vi) $f(x) = 0$ is a polynomial but its degree is **not** defined
- (vii) There are two polynomial functions, satisfying the relation ;
 $f(x) \cdot f(1/x) = f(x) + f(1/x)$. They are :
(a) $f(x) = x^n + 1$ & (b) $f(x) = 1 - x^n$, where n is a positive integer.

(b) Algebraic Function :

A function 'f' is called an algebraic function if it can be constructed using algebraic operations (such as addition, subtraction, multiplication, division, and taking radicals) within polynomials.

Example : $f(x) = \sqrt{x^2 + 1}$; $g(x) = \frac{x^4 - 16x^2}{x + \sqrt{x}} + (x - 2) \sqrt[3]{x + 1}$

y is an algebraic function of x , if it is a function that satisfies an algebraic equation of the form $P_0(x)y^n + P_1(x)y^{n-1} + \dots + P_{n-1}(x)y + P_n(x) = 0$. Where n is a positive integer and $P_0(x), P_1(x), \dots$ are Polynomials in x . e.g. $x^3 + y^3 - 3xy = 0$.

Note :

- (i) All polynomial functions are Algebraic but not the converse.
- (ii) A function that is not algebraic is called **Transcendental Function**.

Basic algebraic function :

(i) $y = x^2$

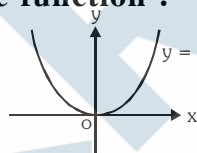

Domain : R

Range : $R^+ \cup \{0\}$ or $[0, \infty)$

(ii) $y = \frac{1}{x}$

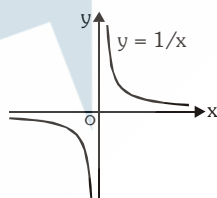

Domain : $R - \{0\}$ or R_0

Range : $R - \{0\}$

(iii) $y = \frac{1}{x^2}$

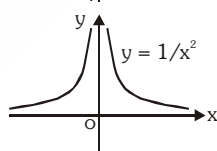

Domain : R_0

Range : R^+ or $(0, \infty)$

(iv) $y = x^3$

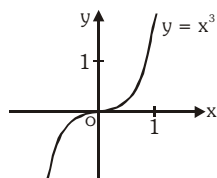

Domain : R

Range : R

(c) **Rational function :**

A rational function is a function of the form $y = f(x) = \frac{g(x)}{h(x)}$, where $g(x)$ & $h(x)$ are polynomials

&

$h(x) \neq 0$, **Domain :** $\mathbb{R} - \{x \mid h(x)=0\}$

Any rational function is automatically an algebraic function.

(d) **Trigonometric functions :**

(i) **Sine function**

$$f(x) = \sin x$$

Domain : \mathbb{R}

Range : $[-1, 1]$, period 2π

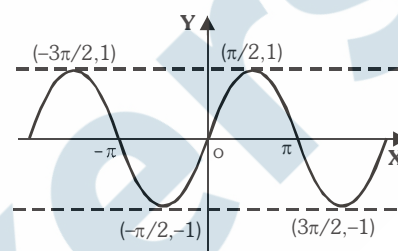

(ii) **Cosine function**

$$f(x) = \cos x$$

Domain : \mathbb{R}

Range : $[-1, 1]$, period 2π

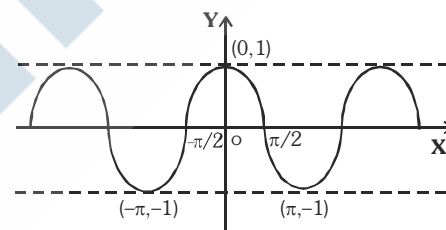

(iii) **Tangent function**

$$f(x) = \tan x$$

Domain : $\mathbb{R} - \left\{ x \mid x = \frac{(2n+1)\pi}{2}, n \in \mathbb{I} \right\}$

Range : \mathbb{R} , period π

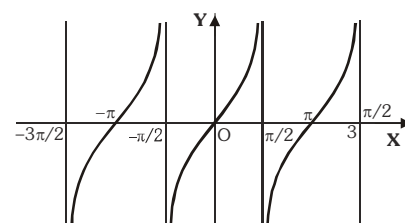

(iv) **Cosecant function**

$$f(x) = \operatorname{cosec} x$$

Domain : $\mathbb{R} - \{x \mid x = n\pi, n \in \mathbb{I}\}$

Range : $\mathbb{R} - (-1, 1)$, period 2π

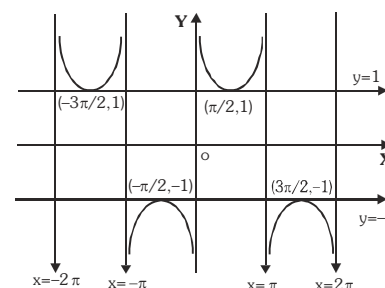

(v) **Secant function**

$$f(x) = \sec x$$

Domain : $\mathbb{R} - \{x|x = (2n + 1) \pi/2 : n \in \mathbb{I}\}$

Range : $\mathbb{R} - (-1, 1)$, period 2π

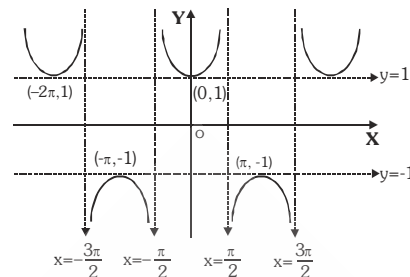

(vi) **Cotangent function**

$$f(x) = \cot x$$

Domain : $\mathbb{R} - \{x|x = n\pi, n \in \mathbb{I}\}$

Range : \mathbb{R} , period π

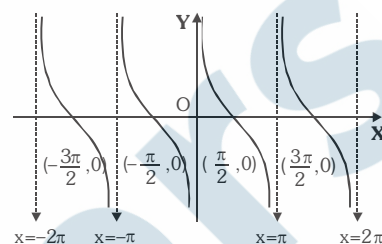

(e) **Exponential and Logarithmic Function :**

A function $f(x) = a^x (a > 0, a \neq 1, x \in \mathbb{R})$ is called an exponential function. The inverse of the exponential function is called the logarithmic function, i.e. $g(x) = \log_a x$.

Note that $f(x)$ & $g(x)$ are inverse of each other & their graphs are as shown. (If functions are mirror image of each other about the line $y = x$)

Domain of a^x is \mathbb{R}

Range \mathbb{R}^+

Domain of $\log_a x$ is \mathbb{R}^+

Range \mathbb{R}

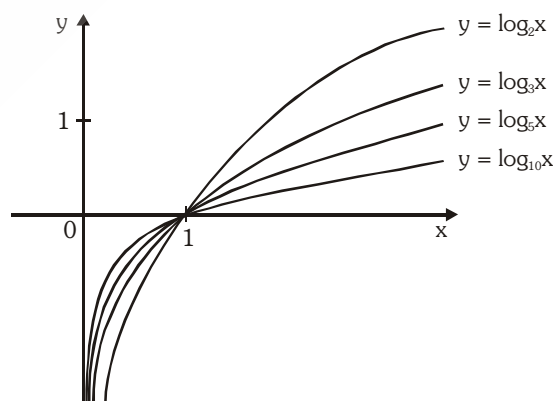
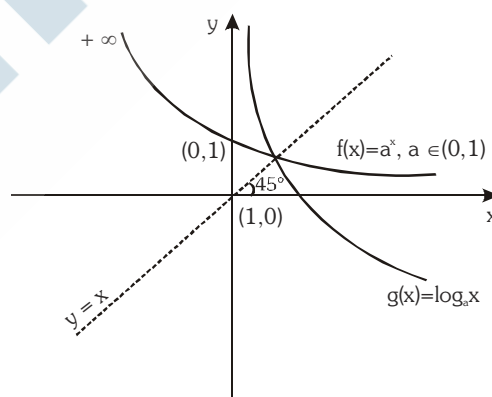
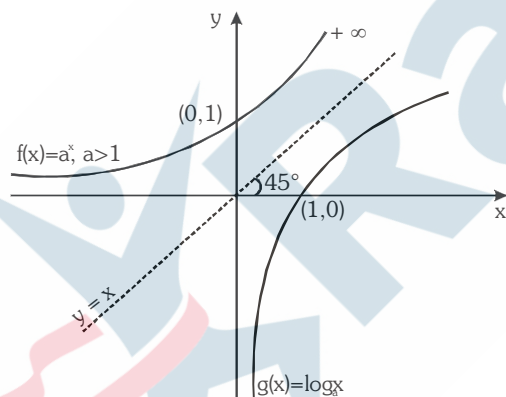

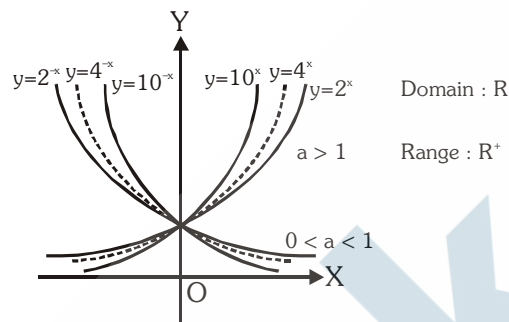
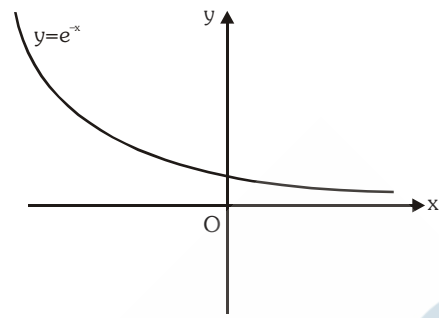
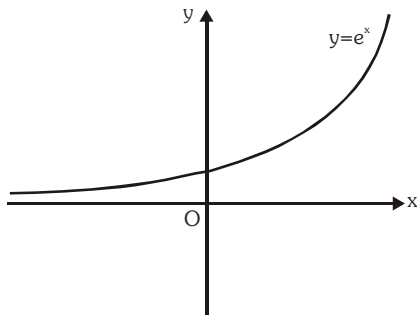

Note-1 : $f(x) = a^{1/x}$, $a > 0$ **Domain :** $\mathbb{R} - \{0\}$ **Range :** $\mathbb{R}^+ - \{1\}$

Note-2 : $f(x) = \log_x a = \frac{1}{\log_a x}$ **Domain :** $\mathbb{R}^+ - \{1\}$ **Range :** $\mathbb{R} - \{0\}$
 $(a > 0) (a \neq 1)$

(f) Absolute Value Function :

A function $y = f(x) = |x|$ is called the absolute value function or Modulus function. It is defined as :

$$y = |x| = \begin{cases} x & \text{if } x \geq 0 \\ -x & \text{if } x < 0 \end{cases}$$

For $f(x) = |x|$, domain is \mathbb{R} and range is $[0, \infty)$

For $f(x) = \frac{1}{|x|}$, domain is $\mathbb{R} - \{0\}$ and range is \mathbb{R}^+ .

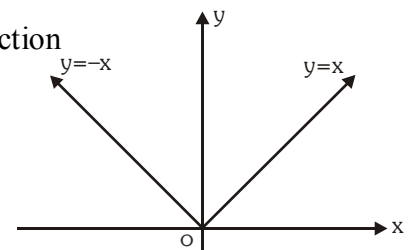

(g) Signum Function :

A function $y = f(x) = \text{Sgn}(x)$ is defined as follows :

$$y = f(x) = \begin{cases} 1 & \text{for } x > 0 \\ 0 & \text{for } x = 0 \\ -1 & \text{for } x < 0 \end{cases}$$

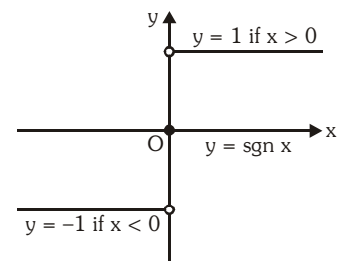

It is also written as $\text{Sgn } x = |x|/x$; $x \neq 0$;
 $= 0$; $x = 0$

Note : $f(x) = (\text{sgn}(x))x \Rightarrow f(x) = |x|$

Domain : \mathbb{R}

Range : $\{-1, 0, 1\}$

(h) Greatest integer or step up function :

The function $y = f(x) = [x]$ is called the greatest integer function where $[x]$ denotes the greatest integer less than or equal to x . Note that for :

x	$[x]$
$[-2, -1)$	-2
$[-1, 0)$	-1
$[0, 1)$	0
$[1, 2)$	1

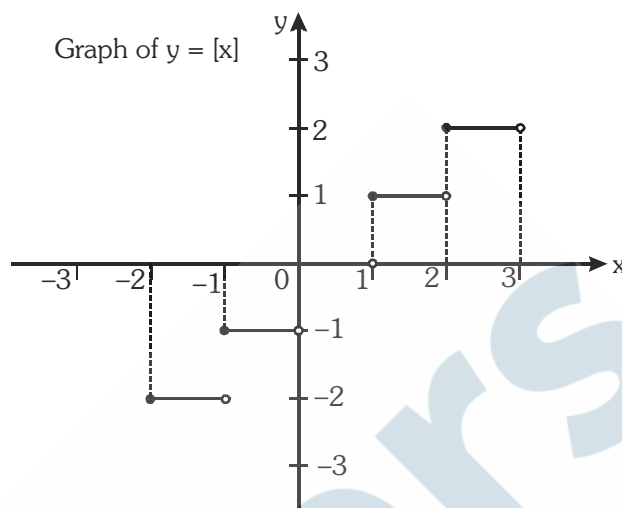

Domain : \mathbb{R}

Range : \mathbb{I}

Properties of greatest integer function :

(i) $[x] \leq x < [x] + 1$ and $x - 1 < [x] \leq x, 0 \leq x - [x] < 1$

(ii) $[x + m] = [x] + m$, if m is an integer.

(iii) $[x] + [-x] = \begin{cases} 0, & x \in \mathbb{I} \\ -1, & x \notin \mathbb{I} \end{cases}$

Illustration 3 : If $y = 2[x] + 3$ & $y = 3[x - 2] + 5$, then find $[x + y]$ where $[\cdot]$ denotes greatest integer function.

Solution : $y = 3[x - 2] + 5 = 3[x] - 1$

so $3[x] - 1 = 2[x] + 3$

$[x] = 4 \Rightarrow 4 \leq x < 5$

then $y = 11$

so $x + y$ will lie in the interval $[15, 16)$

so $[x + y] = 15$

Illustration 4 : Find the value of $\left[\frac{1}{2}\right] + \left[\frac{1}{2} + \frac{1}{1000}\right] + \dots + \left[\frac{1}{2} + \frac{2946}{1000}\right]$ where $[\cdot]$ denotes greatest integer function ?

Solution : $\left[\frac{1}{2}\right] + \left[\frac{1}{2} + \frac{1}{1000}\right] + \dots + \left[\frac{1}{2} + \frac{499}{1000}\right] + \left[\frac{1}{2} + \frac{500}{1000}\right] + \dots + \left[\frac{1}{2} + \frac{1499}{1000}\right] + \left[\frac{1}{2} + \frac{1500}{1000}\right] + \dots$

$+ \left[\frac{1}{2} + \frac{2499}{1000}\right] + \left[\frac{1}{2} + \frac{2500}{1000}\right] + \dots + \left[\frac{1}{2} + \frac{2946}{1000}\right]$

$= 0 + 1 \times 1000 + 2 \times 1000 + 3 \times 447 = 3000 + 1341 = 4341$

Ans.

(i) Fractional part function :

It is defined as : $g(x) = \{x\} = x - [x]$ e.g. the fractional part of the number 2.1 is $2.1 - 2 = 0.1$ and the fractional part of -3.7 is 0.3 . The period of this function is 1 and graph of this function is as shown.

x	{x}
$[-2, -1)$	$x+2$
$[-1, 0)$	$x+1$
$[0, 1)$	x
$[1, 2)$	$x-1$

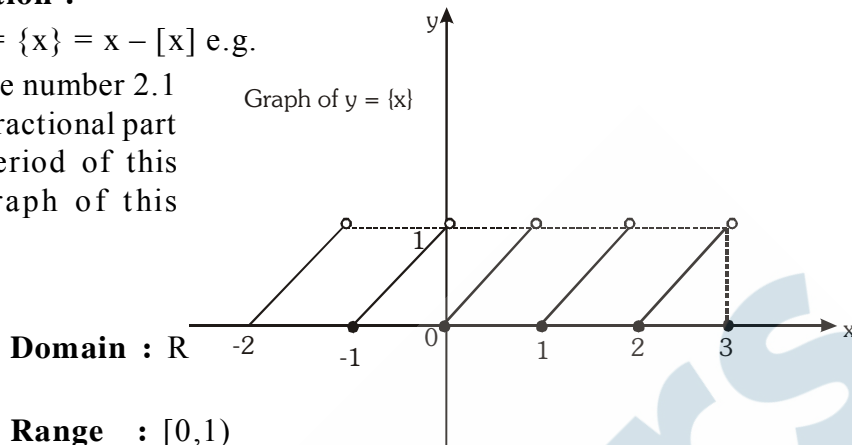

Properties of fractional part function :

- (i) $0 \leq \{x\} < 1$ (ii) $\{[x]\} = [\{x\}] = 0$ (iii) $\{\{x\}\} = \{x\}$
- (iv) $\{x+m\} = \{x\}$, $m \in \mathbb{I}$ (v) $\{x\} + \{-x\} = \begin{cases} 1, & x \notin \mathbb{I} \\ 0, & x \in \mathbb{I} \end{cases}$

Illustration 5 : Solve the equation $|2x - 1| = 3[x] + 2\{x\}$ where $[.]$ denotes greatest integer and $\{.\}$ denotes fractional part function.

Solution : We are given that, $|2x - 1| = 3[x] + 2\{x\}$

Let, $2x - 1 \leq 0$ i.e. $x \leq \frac{1}{2}$. The given equation yields.

$$1 - 2x = 3[x] + 2\{x\}$$

$$\Rightarrow 1 - 2[x] - 2\{x\} = 3[x] + 2\{x\} \Rightarrow 1 - 5[x] = 4\{x\} \Rightarrow \{x\} = \frac{1 - 5[x]}{4}$$

$$\Rightarrow 0 \leq \frac{1 - 5[x]}{4} < 1 \Rightarrow 0 \leq 1 - 5[x] < 4 \Rightarrow -\frac{3}{5} < [x] \leq \frac{1}{5}$$

Now, $[x] = 0$ as zero is the only integer lying between $-\frac{3}{5}$ and $\frac{1}{5}$

$$\Rightarrow \{x\} = \frac{1}{4} \Rightarrow x = \frac{1}{4} \text{ which is less than } \frac{1}{2}, \text{ Hence } \frac{1}{4} \text{ is one solution.}$$

Now, let $2x - 1 > 0$ i.e. $x > \frac{1}{2}$

$$\Rightarrow 2x - 1 = 3[x] + 2\{x\} \Rightarrow 2[x] + 2\{x\} - 1 = 3[x] + 2\{x\}$$

$$\Rightarrow [x] = -1 \Rightarrow -1 \leq x < 0 \text{ which is not a solution as } x > \frac{1}{2}$$

$$\Rightarrow x = \frac{1}{4} \text{ is the only solution.}$$

(j) Identity function :

The function $f : A \rightarrow A$ defined by $f(x) = x \quad \forall x \in A$ is called the identity of A and is denoted by I_A . It is easy to observe that identity function defined on R is a bijection.

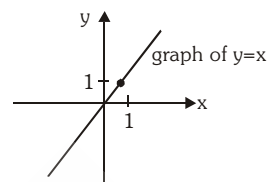

(k) Constant function :

A function $f : A \rightarrow B$ is said to be a constant function if every element of A has the same f image in B . Thus $f : A \rightarrow B ; f(x) = c, \quad \forall x \in A, c \in B$ is a constant function. Note that the range of a constant function is a singleton.

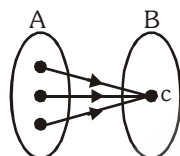
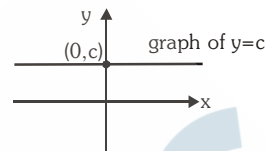

Do yourself - 2 :

(i) Let $\{x\}$ & $[x]$ denotes the fraction and integral part of a real number x respectively, then match the column.

Column-I

- (A) $[x^2] \geq 4$
- (B) $[x]^2 - 5[x] + 6 = 0$
- (C) $x = \{x\}$
- (D) $[x] < -5$

Column-II

- (p) $x \in [2, 4]$
- (q) $x \in (-\infty, -2] \cup [2, \infty)$
- (r) $x \in (-\infty, -5)$
- (s) $x \in \{-2\}$
- (t) $x \in [0, 1]$

5. ALGEBRAIC OPERATIONS ON FUNCTIONS :

If f & g are real valued functions of x with domain set A, B respectively, $f + g, f - g, (f \cdot g)$ & (f/g) as follows :

(a) $(f \pm g)(x) = f(x) \pm g(x)$ domain in each case is $A \cap B$

(b) $(f \cdot g)(x) = f(x) \cdot g(x)$ domain is $A \cap B$

(c) $\left(\frac{f}{g}\right)(x) = \frac{f(x)}{g(x)}$ domain $A \cap B - \{x | g(x) = 0\}$

Illustration 6 : Find the domain of the following function :

(i) $y = \log_{(x-4)}(x^2 - 11x + 24)$ (ii) $f(x) = \log_2 \left(-\log_{1/2} \left(1 + \frac{1}{\sqrt[4]{x}} \right) - 1 \right)$

Solution :

(i) $y = \log_{(x-4)}(x^2 - 11x + 24)$

Here 'y' would assume real value if,

$x - 4 > 0$ and $\neq 1, x^2 - 11x + 24 > 0 \Rightarrow x > 4$ and $\neq 5, (x - 3)(x - 8) > 0$

$\Rightarrow x > 4$ and $\neq 5, x < 3$ or $x > 8 \Rightarrow x > 8 \Rightarrow \text{Domain } (y) = (8, \infty)$

(ii) We have $f(x) = \log_2 \left(-\log_{1/2} \left(1 + \frac{1}{\sqrt[4]{x}} \right) - 1 \right)$

$f(x)$ is defined if $-\log_{1/2} \left(1 + \frac{1}{\sqrt[4]{x}} \right) - 1 > 0$

or if $\log_{1/2} \left(1 + \frac{1}{\sqrt[4]{x}} \right) < -1$ or if $\left(1 + \frac{1}{\sqrt[4]{x}} \right) > (1/2)^{-1}$

or if $1 + \frac{1}{\sqrt[4]{x}} > 2$ or if $\frac{1}{\sqrt[4]{x}} > 1$ or if $x^{1/4} < 1$ or if $0 < x < 1$

$\therefore D(f) = (0, 1)$

Illustration 7 : Find the domain $f(x) = \frac{1}{\sqrt{[|x| - 5] - 11}}$ where $[.]$ denotes greatest integer function.

Solution : $[|x| - 5] > 11$

so $[|x| - 5] > 11$ or $[|x| - 5] < -11$

$[|x|] > 16$ $[|x|] < -6$

$|x| \geq 17$ or $|x| < -6$ (Not Possible)

$\Rightarrow x \leq -17$ or $x \geq 17$

so $x \in (-\infty, -17] \cup [17, \infty)$

Illustration 8 : Find the range of following functions :

(i) $f(x) = \frac{1}{8 - 3 \sin x}$ (ii) $f(x) = \log_{\sqrt{2}} (2 - \log_2 (16 \sin^2 x + 1))$

Solution : (i) $f(x) = \frac{1}{8 - 3 \sin x}$

$-1 \leq \sin x \leq 1$

\therefore Range of $f = \left[\frac{1}{11}, \frac{1}{5} \right]$

(ii) $f(x) = \log_{\sqrt{2}} (2 - \log_2 (16 \sin^2 x + 1))$

$1 \leq 16 \sin^2 x + 1 \leq 17$

$\therefore 0 \leq \log_2 (16 \sin^2 x + 1) \leq \log_2 17$

$\therefore 2 - \log_2 17 \leq 2 - \log_2 (16 \sin^2 x + 1) \leq 2$

Now consider $0 < 2 - \log_2 (16 \sin^2 x + 1) \leq 2$

$\therefore -\infty < \log_{\sqrt{2}} [2 - \log_2 (16 \sin^2 x + 1)] \leq \log_{\sqrt{2}} 2 = 2$

\therefore the range is $(-\infty, 2]$

Illustration 9 : Find the range of $f(x) = \frac{x - [x]}{1 + x - [x]}$, where $[.]$ denotes greatest integer function.

Solution :

$$y = \frac{x - [x]}{1 + x - [x]} = \frac{\{x\}}{1 + \{x\}}$$

$$\therefore \frac{1}{y} = \frac{1}{\{x\}} + 1 \Rightarrow \frac{1}{\{x\}} = \frac{1-y}{y} \Rightarrow \{x\} = \frac{y}{1-y}$$

$$0 \leq \{x\} < 1 \Rightarrow 0 \leq \frac{y}{1-y} < 1$$

Range = $[0, 1/2)$

Do yourself - 3 :

(i) Find domain of following functions :

(a) $f(x) = \sin(\sqrt{1-x^2}) + \sqrt{x+2} + \frac{1}{\log_{10}^{(x+1)}}$

(b) $f(x) = \sqrt{\frac{(2x+1)}{x^3 - 3x^2 + 2x}}$

(ii) Find range of following functions :

(a) $f(x) = \log_2(\log_{1/2}(x^2 + 4x + 4))$

(b) $f(x) = \frac{1}{2 - \cos 3x}$

6. EQUAL OR IDENTICAL FUNCTION :

Two function f & g are said to be equal if :

- (a) The domain of f = the domain of g
- (b) The co-domain of f = co-domain of g and
- (c) $f(x) = g(x)$, for every x belonging to their common domain (i.e. should have the same graph)

Illustration 10 : The functions $f(x) = \log(x-1) - \log(x-2)$ and $g(x) = \log\left(\frac{x-1}{x-2}\right)$ are identical when x lies in the interval

- (A) $[1, 2]$ (B) $[2, \infty)$ (C) $(2, \infty)$ (D) $(-\infty, \infty)$

Solution : Since $f(x) = \log(x-1) - \log(x-2)$.
 Domain of $f(x)$ is $x > 2$ or $x \in (2, \infty)$ (i)

$g(x) = \log\left(\frac{x-1}{x-2}\right)$ is defined if $\frac{x-1}{x-2} > 0 \Rightarrow x \in (-\infty, 1) \cup (2, \infty)$ (ii)

From (i) and (ii), $x \in (2, \infty)$. **Ans. (C)**

Do yourself - 4 :

(i) Are the following functions identical ?

(a) $f(x) = \frac{x}{x^2}$ & $\phi(x) = \frac{x^2}{x}$ (b) $f(x) = x$ & $\phi(x) = \sqrt{x^2}$ (c) $f(x) = \log_{10} x^2$ & $\phi(x) = 2 \log_{10} |x|$

7. HOMOGENEOUS FUNCTIONS :

A function is said to be homogeneous with respect to any set of variables when each of its terms is of the same degree with respect to those variables.

For examples $5x^2 + 3y^2 - xy$ is homogenous in x & y . Symbolically if, $f(tx, ty) = t^n f(x, y)$ then $f(x, y)$ is homogeneous function of degree n .

Illustration 11 : Which of the following function is not homogeneous ?

(A) $x^3 + 8x^2y + 7y^3$ (B) $y^2 + x^2 + 5xy$ (C) $\frac{xy}{x^2 + y^2}$ (D) $\frac{2x - y + 1}{2y - x + 1}$

Solution : It is clear that (D) does not have the same degree in each term. **Ans. (D)**

8. BOUNDED FUNCTION :

A function is said to be bounded if there exists a finite M such that $|f(x)| \leq M, \forall x \in D_f$.

9. IMPLICIT & EXPLICIT FUNCTION :

A function defined by an equation not solved for the dependent variable is called an **implicit function**. e.g. the equations $x^3 + y^3 = 1$ & $x^y = y^x$, defines y as an implicit function. If y has been expressed in terms of x alone then it is called an **Explicit function**.

Illustration 12 : Which of the following function is implicit function ?

(A) $y = \frac{x^2 + e^x + 5}{\sqrt{1 - \cos^{-1} x}}$ (B) $y = x^2$ (C) $xy - \sin(x + y) = 0$ (D) $y = \frac{x^2 \log x}{\sin x}$

Solution : It is clear that in (C) y is not clearly expressed in x . **Ans. (C)**

Do yourself - 5 :

(i) Find the boundness of the function $f(x) = \frac{x^2}{x^4 + 1}$

(ii) Which of the following function is implicit function ?

(A) $xy - \cos(x + y) = 0$ (B) $y = x^3$

(C) $y = \log(x^2 + x + 1)$ (D) $y = |x|$

(iii) Convert the implicit form into the explicit function :

(a) $xy = 1$ (b) $x^2y = 1$.

10. APPLICATIONS OF FUNCTIONAL RULE :

Illustration 13 : Determine all functions f satisfying the functional relation.

$$f(x) + f\left(\frac{1}{1-x}\right) = \frac{2(1-2x)}{x(1-x)} \text{ where } x \in \mathbb{R} - \{0, 1\}$$

Solution : Given $f(x) + f\left(\frac{1}{1-x}\right) = \frac{2(1-2x)}{x(1-x)} = \frac{2}{x} - \frac{2}{1-x}$... (i)

Replacing x by $\frac{1}{1-x}$ we obtain

$$f\left(\frac{1}{1-x}\right) + f\left(\frac{1}{1-\frac{1}{1-x}}\right) = 2(1-x) - \frac{2}{1-\frac{1}{1-x}}$$

$$\Rightarrow f\left(\frac{1}{1-x}\right) + f\left(1 - \frac{1}{x}\right) = -2x + \frac{2}{x}$$
 ... (ii)

Again replacing x by $\left(1 - \frac{1}{x}\right)$ in (i) we obtain

$$\Rightarrow f\left(1 - \frac{1}{x}\right) + f\left(\frac{1}{1-\left(1-\frac{1}{x}\right)}\right) = \frac{2}{1-\frac{1}{x}} - \frac{2}{1-\left(1-\frac{1}{x}\right)}$$

$$\Rightarrow f\left(1 - \frac{1}{x}\right) + f(x) = \frac{2x}{x-1} - 2x$$
 ... (iii)

subtracting (ii) from (i) then

$$f(x) - f\left(1 - \frac{1}{x}\right) = 2x - \frac{2}{1-x}$$

Now adding (iii) and (iv) we get

$$2f(x) = \frac{2x}{x-1} - \frac{2}{1-x}$$

$$\Rightarrow f(x) = \frac{x+1}{x-1}$$

11. BASIC TRANSFORMATIONS ON GRAPHS :

(i) Drawing the graph of $y = f(x) + b$, $b \in \mathbf{R}$, from the known graph of $y = f(x)$

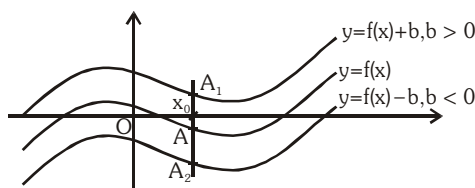

It is obvious that domain of $f(x)$ and $f(x) + b$ are the same. Let us take any point x_0 in the domain of $f(x)$. $y|_{x=x_0} = f(x_0)$.

The corresponding point on $f(x) + b$ would be $f(x_0) + b$.

For $b > 0 \Rightarrow f(x_0) + b > f(x_0)$ it means that the corresponding point on $f(x) + b$ would be lying at a distance 'b' units above the point on $f(x)$.

For $b < 0 \Rightarrow f(x_0) + b < f(x_0)$ it means that the corresponding point on $f(x) + b$ would be lying at a distance 'b' units below the point on $f(x)$.

Accordingly the graph of $f(x) + b$ can be obtained by translating the graph of $f(x)$ either in the positive y-axis direction (if $b > 0$) or in the negative y-axis direction (if $b < 0$), through a distance $|b|$ units.

(ii) Drawing the graph of $y = -f(x)$ from the known graph of $y = f(x)$

To draw $y = -f(x)$, take the image of the curve $y = f(x)$ in the x-axis as plane mirror.

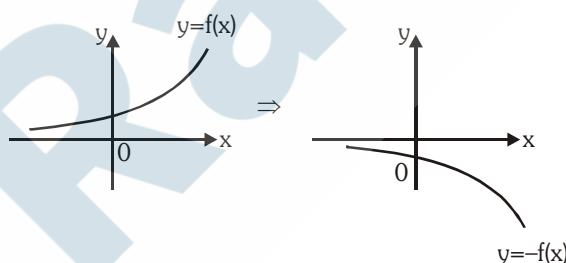

(iii) Drawing the graph of $y = f(-x)$ from the known graph of $y = f(x)$

To draw $y = f(-x)$, take the image of the curve $y = f(x)$ in the y-axis as plane mirror.

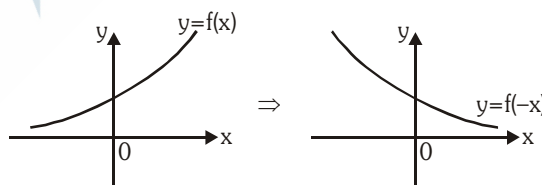

(iv) Drawing the graph of $y = |f(x)|$ from the known graph of $y = f(x)$

$|f(x)| = f(x)$ if $f(x) \geq 0$ and $|f(x)| = -f(x)$ if $f(x) < 0$. It means that the graph of $f(x)$ and $|f(x)|$ would coincide if $f(x) \geq 0$ and for the portions where $f(x) < 0$ graph of $|f(x)|$ would be image of $y = f(x)$ in x-axis.

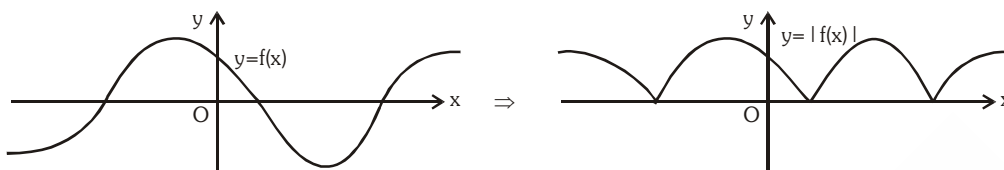

(v) Drawing the graph of $y = f(|x|)$ from the known graph of $y = f(x)$

It is clear that, $f(|x|) = \begin{cases} f(x), & x \geq 0 \\ f(-x), & x < 0 \end{cases}$. Thus $f(|x|)$ would be an even function, graph of $f(|x|)$ and $f(x)$

would be identical in the first and the fourth quadrants (as $x \geq 0$) and as such the graph of $f(|x|)$ would be symmetric about the y-axis (as $(|x|)$ is even).

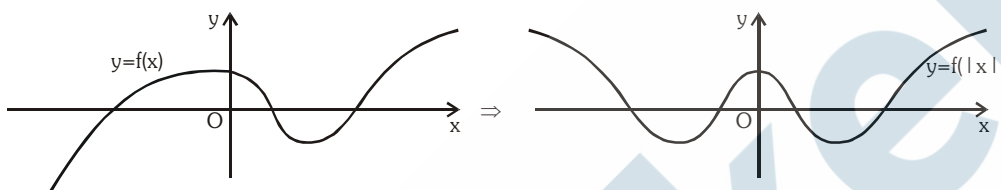

(vi) Drawing the graph of $|y| = f(x)$ from the known graph of $y = f(x)$

Clearly $|y| \geq 0$. If $f(x) < 0$, graph of $|y| = f(x)$ would not exist. And if $f(x) \geq 0$, $|y| = f(x)$ would give $y = \pm f(x)$. Hence graph of $|y| = f(x)$ would exist only in the regions where $f(x)$ is non-negative and will be reflected about the x-axis only in those regions.

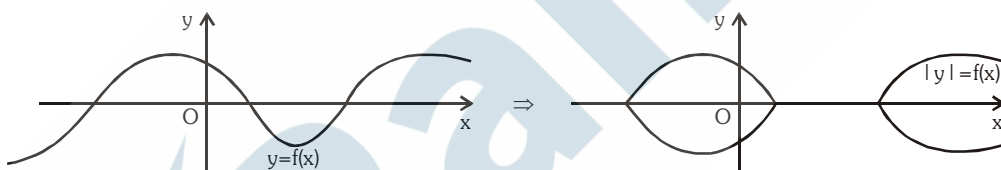

(vii) Drawing the graph of $y = f(x + a)$, $a \in \mathbb{R}$ from the known graph of $y = f(x)$

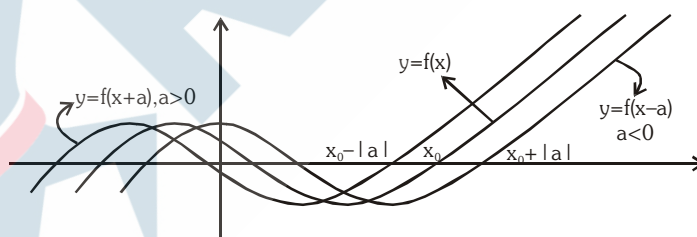

(i) If $a > 0$, shift the graph of $f(x)$ through 'a' units towards left of $f(x)$.

(ii) If $a < 0$, shift the graph of $f(x)$ through 'a' units towards right of $f(x)$.

(viii) Drawing the graph of $y = af(x)$ from the known graph of $y = f(x)$

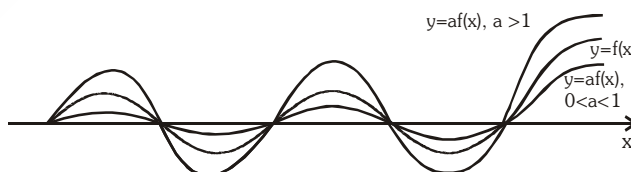

It is clear that the corresponding points (points with same x co-ordinates) would have their ordinates in the ratio of $1 : a$.

(ix) Drawing the graph of $y = f(ax)$ from the known graph of $y = f(x)$.

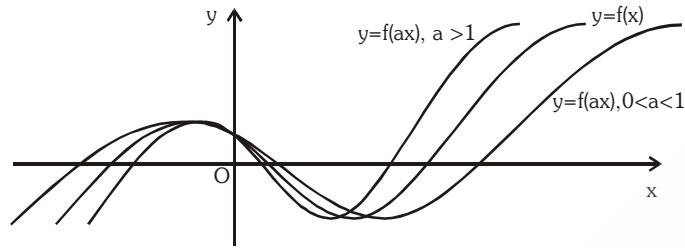

Let us take any point $x_0 \in \text{domain of } f(x)$. Let $ax = x_0$ or $x = \frac{x_0}{a}$.

Clearly if $0 < a < 1$, then $x > x_0$ and $f(x)$ will stretch by $\frac{1}{a}$ units along the x-axis and if $a > 1$, $x < x_0$, then $f(x)$ will compress by 'a' units along the x-axis.

Note :

(i) A function $h(x)$ is defined as $h(x) = \max. \{f(x), g(x)\}$ then

$$h(x) = \begin{cases} f(x) & f(x) \geq g(x) \\ g(x) & g(x) > f(x) \end{cases}$$

(ii) A function $h(x)$ is defined as

$h(x) = \min. \{f(x), g(x)\}$ then

$$h(x) = \begin{cases} f(x) & f(x) \leq g(x) \\ g(x) & g(x) < f(x) \end{cases}$$

Illustration 14: Find $f(x) = \max \{1 + x, 1 - x, 2\}$.

Solution : From the graph it is clear that

$$f(x) = \begin{cases} 1 - x; & x < -1 \\ 2 & -1 \leq x \leq 1 \\ 1 + x; & x > 1 \end{cases}$$

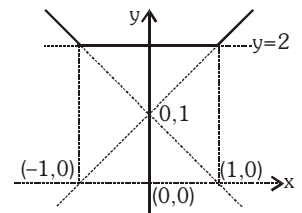
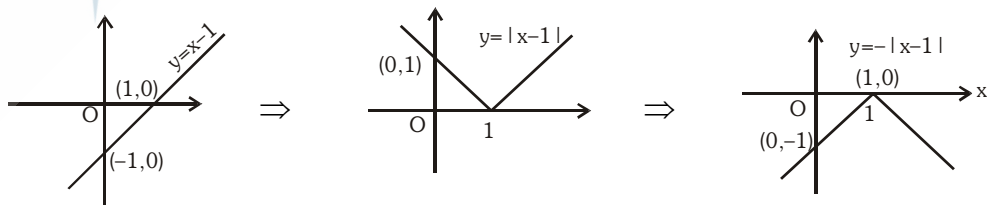

Illustration 15: Draw the graph of $y = |2 - |x - 1||$.

Solution :



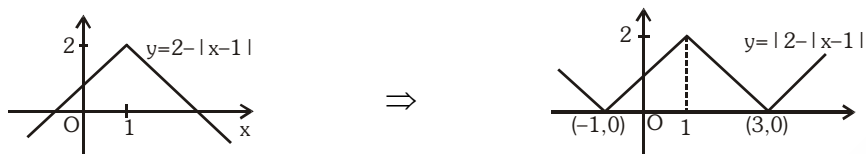

Illustration 16: Draw the graph of $y = 2 - \frac{4}{|x-1|}$

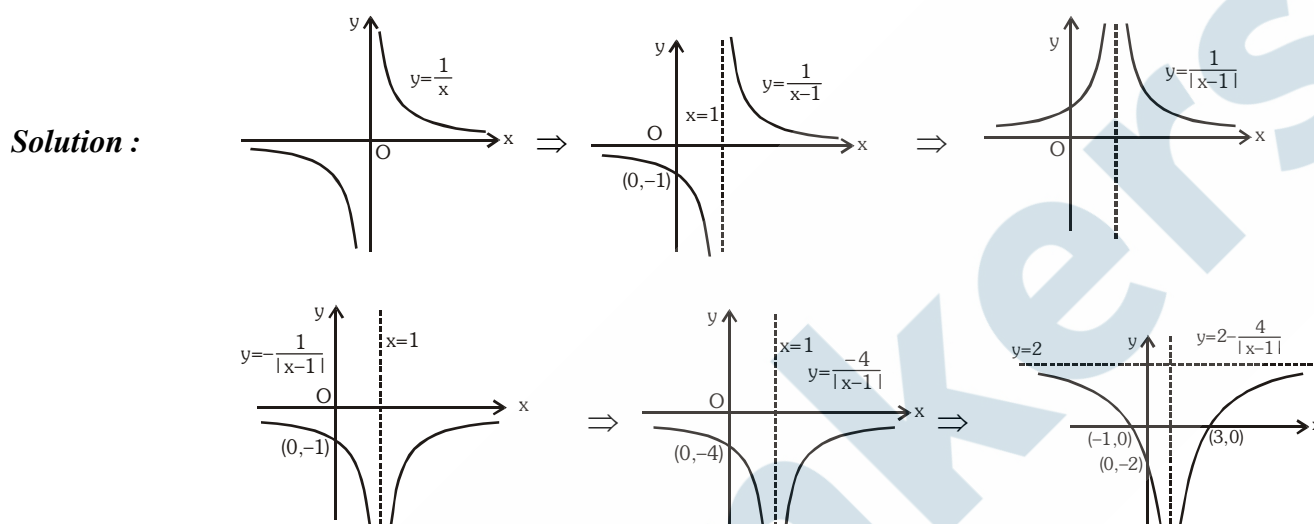

Illustration 17: Draw the graph of $y = |e^{|x|} - 2|$

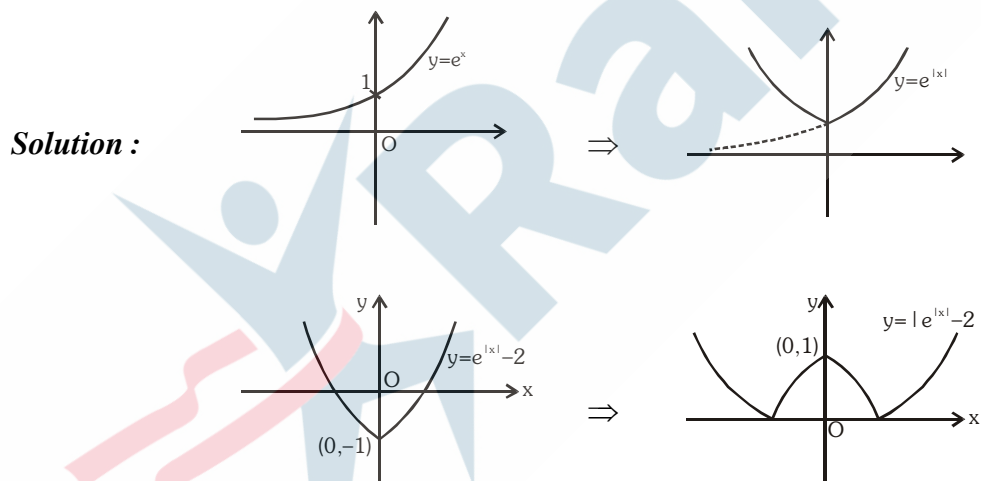

Illustration 18: Draw the graph of $f(x) = \cos x \cos(x + 2) - \cos^2(x + 1)$.

Solution :

$$f(x) = \cos x \cos(x + 2) - \cos^2(x + 1)$$

$$= \frac{1}{2} [\cos(2x + 2) + \cos 2] - \frac{1}{2} [\cos(2x + 2) + 1]$$

$$= \frac{1}{2} \cos 2 - \frac{1}{2} < 0.$$

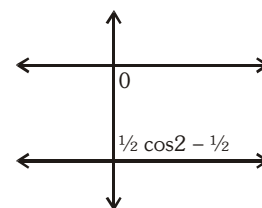

Do yourself - 6 :

(i) Draw graph of following functions :

(a) $y = |\ln|x|| + 1$

(b) $y = \min. \{x^2 + 1, 3-x\}$

12. CLASSIFICATION OF FUNCTIONS :

One-One Function (Injective mapping) :

A function $f : A \rightarrow B$ is said to be a one-one function or injective mapping if different elements of A have different f images in B.

Thus there exist $x_1, x_2 \in A$ & $f(x_1), f(x_2) \in B$, $f(x_1) = f(x_2) \Leftrightarrow x_1 = x_2$ or $x_1 \neq x_2 \Leftrightarrow f(x_1) \neq f(x_2)$.

Diagrammatically an injective mapping can be shown as

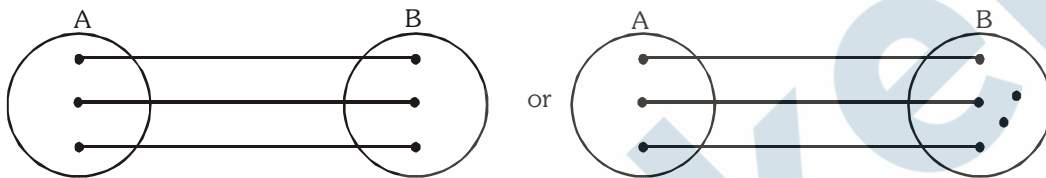

Many-one function (not injective) :

A function $f : A \rightarrow B$ is said to be a many one function if two or more elements of A have the same f image in B.

Thus $f : A \rightarrow B$ is many one there exist $x_1, x_2 \in A$, $f(x_1) = f(x_2)$ but $x_1 \neq x_2$.

Diagrammatically a many one mapping can be shown as

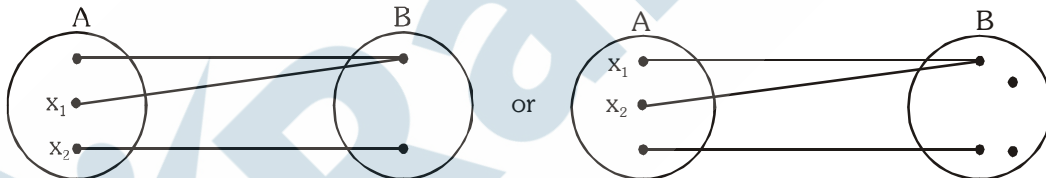

Note :

- (i) If a line parallel to x-axis cuts the graph of the function at most at one point, then the function is one-one.
- (ii) If any line parallel to x-axis cuts the graph of the function at least at two points, then f is many-one.
- (iii) If continuous function $f(x)$ is always increasing or decreasing in whole domain, then $f(x)$ is one-one.
- (iv) All linear functions are one-one.
- (v) All trigonometric functions in their domain are many one
- (vi) All even degree polynomials are many one
- (vii) Linear by Linear is one-one
- (viii) Quadratic by quadratic with no common factor is many one.

Onto function (Surjective mapping) :

If the function $f : A \rightarrow B$ is such that each element in B (co-domain) is the f image of atleast one element in A, then we say that f is a function from A 'onto' B. Thus $f : A \rightarrow B$ is surjective iff $\forall b \in B, \exists$ some $a \in A$ such that $f(a) = b$.

Diagrammatically surjective mapping can be shown as

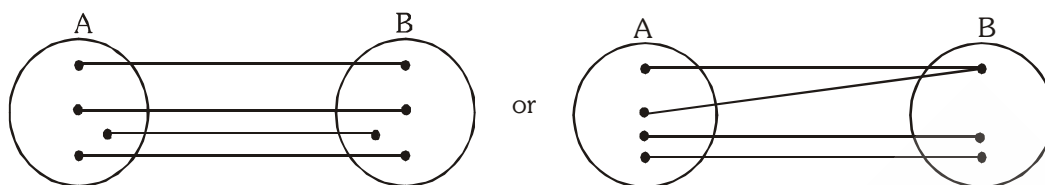

Note that : if range is same as co-domain, then $f(x)$ is onto.

Into function :

If $f : A \rightarrow B$ is such that there exists atleast one element in co-domain which is not the image of any element in domain, then $f(x)$ is into.

Diagrammatically into function can be shown as

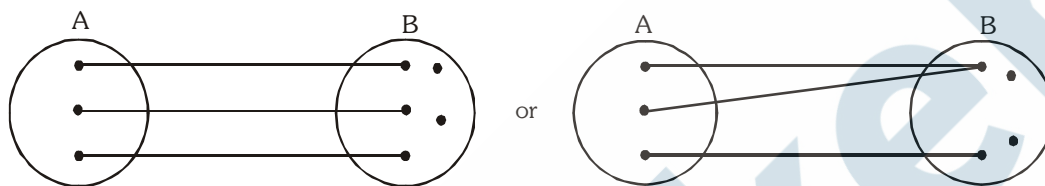

Note :

- (i) A polynomial function of degree even define from $\mathbb{R} \rightarrow \mathbb{R}$ will always be into.
- (ii) A polynomial function of degree odd defined from $\mathbb{R} \rightarrow \mathbb{R}$ will always be onto.
- (iii) Quadratic by quadratic without any common factor define from $\mathbb{R} \rightarrow \mathbb{R}$ is always an into function.

Thus a function can be one of these four types :

- (i) one-one onto (injective & surjective)
(also known as **Bijective** mapping)
- (ii) one-one into (injective but not surjective)
- (iii) many-one onto (surjective but not injective)
- (iv) many-one into (neither surjective nor injective)

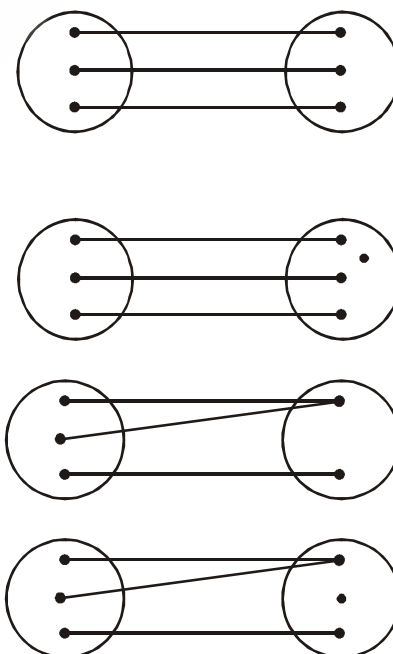

Illustration 19 : Let $A = \{x : -1 \leq x \leq 1\} = B$ be a mapping $f : A \rightarrow B$. For each of the following functions from A to B, find whether it is bijective or non-bijective.

- (a) $f(x) = x|x|$
- (b) $f(x) = x^3$
- (c) $f(x) = \sin \frac{\pi x}{2}$

Solution :

$$(a) f(x) = x|x| = \begin{cases} -x^2, & -1 < x < 0 \\ x^2, & 0 \leq x < 1 \end{cases}$$

Graphically,

The graph shows $f(x)$ is one-one, as the straight line parallel to x-axis cuts only at one point.

Here, range

$$f(x) \in [-1, 1]$$

Thus, range = co-domain

Hence, onto.

Therefore, $f(x)$ is one-one onto or (Bijective).

$$(b) f(x) = x^3,$$

Graphically;

Graph shows $f(x)$ is one-one onto

(i.e. Bijective)

[as explained in above example]

$$(c) f(x) = \sin \frac{\pi x}{2}$$

Graphically;

Which shows $f(x)$ is one-one and onto as range

= co-domain.

Therefore, $f(x)$ is bijective.

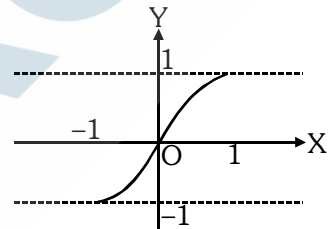
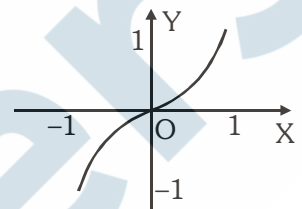
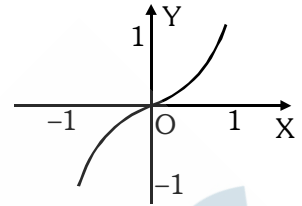

Illustration 20 :

Let $f : \mathbb{N} \rightarrow \mathbb{I}$ be a function defined as $f(x) = x - 1000$. Show that $f(x)$ is an into function.

Solution :

$$\text{Let } f(x) = y = x - 1000 \Rightarrow x = y + 1000 = g(y) \text{ (say)}$$

here $g(y)$ is defined for each $y \in \mathbb{I}$, but $g(y) \notin \mathbb{N}$ for $y \leq -1000$.

Hence $f(x)$ is into.

Illustration 21 :

Let $f : \mathbb{R} \rightarrow \mathbb{R}$ be a function defined by $f(x) = x + \sqrt{x^2}$, then f is

- (A) injective (B) surjective (C) bijective (D) None of these

Solution :

$$\text{We have, } f(x) = x + \sqrt{x^2} = x + |x|$$

Clearly, f is not one-one as $f(-1) = f(-2) = 0$ and $-1 \neq -2$

Also, f is not onto as $f(x) \geq 0 \forall x \in \mathbb{R}$

\therefore range of $f = (0, \infty) \subset \mathbb{R}$

Ans.(D)

Illustration 22 :

Let $f : \mathbb{R} \rightarrow \mathbb{R}$ be a function defined as $f(x) = 2x^3 + 6x^2 + 12x + 3 \cos x - 4 \sin x$; then f is -

- (A) Injective (B) Surjective (C) Bijective (D) Not Surjective

Solution :

$$\text{We have } f(x) = 2x^3 + 6x^2 + 12x + 3 \cos x - 4 \sin x$$

$$\Rightarrow f'(x) = 6x^2 - 12x + 12 - 3 \sin x - 4 \cos x$$

$$f'(x) = \underbrace{6(x-1)^2 + 6}_{g(x)} - \underbrace{(3 \sin x + 4 \cos x)}_{h(x)}$$

$$\text{range of } g(x) = [6, \infty)$$

$$\text{range of } h(x) = [-5, 5]$$

hence $f'(x)$ always lies in the interval $[1, \infty)$

$$\Rightarrow f'(x) > 0$$

Hence $f(x)$ is increasing i.e. one-one function

Now $x \rightarrow \infty \Rightarrow f \rightarrow \infty$ & $x \rightarrow -\infty \Rightarrow f \rightarrow -\infty$ & $f(x)$ is continuous

hence its range is $\mathbb{R} \Rightarrow f$ is onto so f is bijective.

Ans. (C)

Illustration 23 : Let $f(x) = \frac{x^2 + 3x + a}{x^2 + x + 1}$, where $f: \mathbb{R} \rightarrow \mathbb{R}$. Find the value of parameter 'a' so that the given function is one-one.

Solution : $f(x) = \frac{x^2 + 3x + a}{x^2 + x + 1}$

$$f'(x) = \frac{(x^2 + x + 1)(2x + 3) - (x^2 + 3x + a)(2x + 1)}{(x^2 + x + 1)^2} = \frac{-2x^2 + 2x(1 - a) + (3 - a)}{(x^2 + x + 1)^2}$$

Let, $g(x) = -2x^2 + 2x(1 - a) + (3 - a)$

$g(x)$ will be negative if $4(1 - a)^2 + 8(3 - a) < 0$

$$\Rightarrow 1 + a^2 - 2a + 6 - 2a < 0 \Rightarrow (a - 2)^2 + 3 < 0$$

which is not possible. Therefore function is not monotonic.

Hence, no value of a is possible.

Do yourself - 7 :

- (i) Is the function $f: \mathbb{N} \rightarrow \mathbb{N}$ (the set of natural numbers) defined by $f(x) = 2x + 3$ surjective ?
- (ii) Let $A = \mathbb{R} - \{3\}$, $B = \mathbb{R} - \{1\}$ and let $f: A \rightarrow B$ defined by $f(x) = \frac{x-2}{x-3}$. Check whether the function $f(x)$ is bijective or not.
- (iii) A mapping $f: A \rightarrow [-1, 1]$ defined by $f(x) = \sin x$, $\forall x \in \mathbb{R}$, where A is a subset of \mathbb{R} (the set of all real numbers) is one-one and onto if A is the interval, then A belongs to

- (A) $[0, 2\pi]$ (B) $\left[-\frac{\pi}{2}, \frac{\pi}{2}\right]$ (C) $[-\pi, \pi]$ (D) $[0, \pi]$

13. COMPOSITE OF UNIFORMLY & NON-UNIFORMLY DEFINED FUNCTION:

Let $f: A \rightarrow B$ & $g: B \rightarrow C$ be two functions. Then the function $g \circ f: A \rightarrow C$ defined by $(g \circ f)(x) = g(f(x))$ $\forall x \in A$ is called the composite of the two functions f & g .

Diagrammatically $x \rightarrow \boxed{f} \xrightarrow{f(x)} \boxed{g} \rightarrow g(f(x))$

Thus the image of every $x \in A$ under the function $g \circ f$ is the g -image of f -image of x .

Note that $g \circ f$ is defined only if $\forall x \in A$, $f(x)$ is an element of the domain of ' g ' so that we can take its g -image.

Properties of composite functions:

- (a) In general composite of functions is not commutative i.e. $g \circ f \neq f \circ g$.

- (b) The composition of functions is associative i.e. if f, g, h are three functions such that $fo(goh)$ & $(fog)oh$ are defined, then $fo(goh) = (fog)oh$.
- (c) The composition of two bijections is a bijection i.e. if f & g are two bijections such that gof is defined, then gof is also a bijection.

Illustration 24: If $f(x) = x^2 + 1$, $g(x) = \frac{1}{x-1}$, then find $(fog)(x)$ and $(gof)(x)$.

Solution : Given, $f(x) = x^2 + 1$ (1) $g(x) = \frac{1}{x-1}$... (2)

Now $(fog)(x) = f(g(x)) = f\left(\frac{1}{x-1}\right) = f(z)$, where $z = \frac{1}{x-1}$

$= z^2 + 1$ [$\because f(x) = x^2 + 1$]

$$= \left(\frac{1}{x-1}\right)^2 + 1 = \frac{1}{(x-1)^2} + 1$$

Note : Domain of $(fog)(x)$ is $x \in \mathbb{R} - \{1\}$

$(gof)(x) = g(f(x)) = g(x^2 + 1) = g(u)$, where $u = x^2 + 1$

$$= \frac{1}{u-1} = \frac{1}{x^2 + 1 - 1} = \frac{1}{x^2}$$

Note : Domain of $(gof)(x)$ is $x \in \mathbb{R} - \{0\}$

Illustration 25: If f be the greatest integer function and g be the modulus function, then

$$(gof)\left(-\frac{5}{3}\right) - (fog)\left(-\frac{5}{3}\right) =$$

- (A) 1 (B) -1 (C) 2 (D) 4

Solution : Given $(gof)\left(-\frac{5}{3}\right) - (fog)\left(-\frac{5}{3}\right) = g\left\{f\left(-\frac{5}{3}\right)\right\} - f\left\{g\left(-\frac{5}{3}\right)\right\} = g(-2) - f\left(\frac{5}{3}\right) = 2 - 1 = 1$

Ans.(A)

Illustration 26: Let $f(x) = \begin{cases} x+1, & x \leq 1 \\ 2x+1, & 1 < x \leq 2 \end{cases}$ and $g(x) = \begin{cases} x^2, & -1 \leq x < 2 \\ x+2, & 2 \leq x \leq 3 \end{cases}$, find (fog)

Solution : $f(g(x)) = \begin{cases} g(x)+1, & g(x) \leq 1 \\ 2g(x)+1, & 1 < g(x) \leq 2 \end{cases}$

Here, $g(x)$ becomes the variable that means we should draw the graph.

It is clear that $g(x) \leq 1$; $\forall x \in [-1, 1]$

and $1 < g(x) \leq 2$; $\forall x \in (1, \sqrt{2}]$

$$\Rightarrow f(g(x)) = \begin{cases} x^2 + 1, & -1 \leq x \leq 1 \\ 2x^2 + 1, & 1 < x \leq \sqrt{2} \end{cases}$$

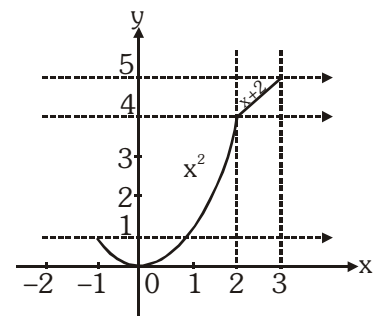

Illustration 27: Find the domain and range of $h(x) = g(f(x))$, where

$$f(x) = \begin{cases} [x], & -2 \leq x \leq -1 \\ |x|+1, & -1 < x \leq 2 \end{cases} \text{ and } g(x) = \begin{cases} [x], & -\pi \leq x \leq 0 \\ \sin x, & 0 \leq x \leq \pi \end{cases}, [.] \text{ denotes the greatest integer function.}$$

Solution :
$$h(x) = g(f(x)) = \begin{cases} [f(x)], & -\pi \leq f(x) < 0 \\ \sin(f(x)), & 0 \leq f(x) \leq \pi \end{cases}$$

From graph of $f(x)$, we get

$$h(x) = \begin{cases} [[x]], & -2 \leq x \leq -1 \\ \sin(|x|+1), & -1 < x \leq 2 \end{cases}$$

\Rightarrow Domain of $h(x)$ is $[-2, 2]$
and Range of $h(x)$ is $\{-2, -1\} \cup [\sin 3, 1]$

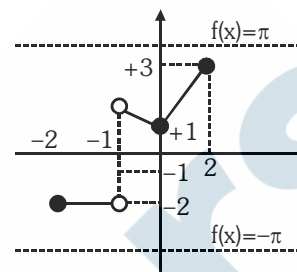

Do yourself - 8 :

(i) $f(x) = x^3 - x$ & $g(x) = \sin 2x$, find

- | | | |
|---|----------------|---|
| (a) $f(f(1))$ | (b) $f(f(-1))$ | (c) $f\left(g\left(\frac{\pi}{2}\right)\right)$ |
| (d) $f\left(g\left(\frac{\pi}{4}\right)\right)$ | (e) $g(f(1))$ | (f) $g\left(g\left(\frac{\pi}{2}\right)\right)$ |

(ii) If $f(x) = \begin{cases} x+1; & 0 \leq x < 2 \\ |x|; & 2 \leq x < 3 \end{cases}$, then find $f \circ f(x)$.

14. INVERSE OF A FUNCTION :

Let $f : A \rightarrow B$ be a one-one & onto function, then there exists a unique function $g : B \rightarrow A$ such that $f(x) = y \Leftrightarrow g(y) = x, \forall x \in A \text{ \& } y \in B$. Then g is said to be inverse of f .

Thus $g = f^{-1} : B \rightarrow A = \{(f(x), x) | (x, f(x)) \in f\}$.

Properties of inverse function :

- (a) The inverse of a bijection is unique.
- (b) If $f : A \rightarrow B$ is a bijection & $g : B \rightarrow A$ is the inverse of f , then $f \circ g = I_B$ and $g \circ f = I_A$, where I_A & I_B are identity functions on the sets A & B respectively. If $f \circ f = I$, then f is inverse of itself.
- (c) The inverse of a bijection is also a bijection.
- (d) If f & g are two bijections $f : A \rightarrow B, g : B \rightarrow C$ then the inverse of $g \circ f$ exists and $(g \circ f)^{-1} = f^{-1} \circ g^{-1}$.

- (e) Since $f(a) = b$ if and only if $f^{-1}(b) = a$, the point (a, b) is on the graph of f if and only if the point (b, a) is on the graph of f^{-1} . But we get the point (b, a) from (a, b) by reflecting about the line $y = x$.

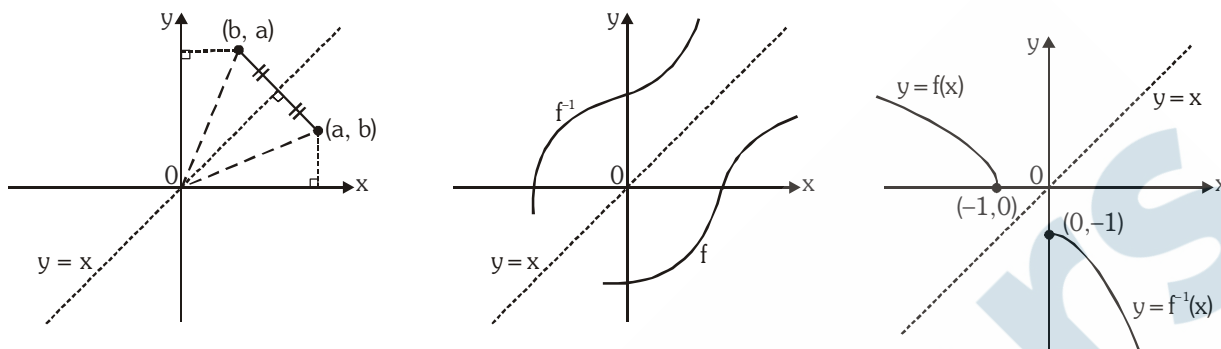

The graph of f^{-1} is obtained by reflecting the graph of f about the line $y = x$.

Drawing the graph of $y = f^{-1}(x)$ from the known graph of $y = f(x)$

For drawing the graph of $y = f^{-1}(x)$ take the reflection of $y = f(x)$ about the line $y = x$. The reflected part would give us the graph of $y = f^{-1}(x)$.

e.g. let us draw the graph of $y = \sin^{-1}x$. We know that $y = f(x) = \sin x$ is invertible if

$$f: \left[-\frac{\pi}{2}, \frac{\pi}{2}\right] \rightarrow [-1, 1] \Rightarrow \text{the inverse mapping would be } f^{-1}: [-1, 1] \rightarrow \left[-\frac{\pi}{2}, \frac{\pi}{2}\right].$$

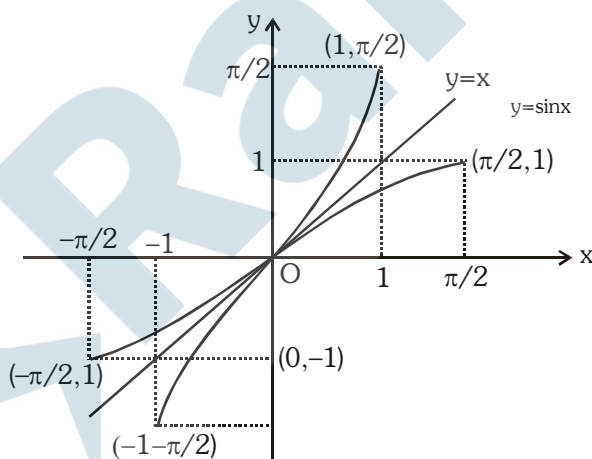

Illustration 28: Let $f: \mathbb{R} \rightarrow \mathbb{R}$ be defined by $f(x) = \frac{e^x - e^{-x}}{2}$. Is $f(x)$ invertible? If so, find its inverse.

Solution : Let us check for invertibility of $f(x)$:

(a) One-One :

$$f(x) = \frac{1}{2}(e^x - e^{-x}) \Rightarrow f'(x) = \frac{1}{2}(e^x + e^{-x})$$

$\Rightarrow f'(x) > 0$, $f(x)$ is increasing function

$\therefore f(x)$ is one-one function.

(b) Onto :

As x tends to larger and larger values so does $f(x)$ and

when $x \rightarrow \infty$, $f(x) \rightarrow \infty$.

Similarly as $x \rightarrow -\infty$, $f(x) \rightarrow -\infty$ i.e. $-\infty < f(x) < \infty$ so long as $x \in (-\infty, \infty)$

Hence the range of f is same as the set \mathbb{R} . Therefore $f(x)$ is onto.

Since $f(x)$ is both one-one and onto, $f(x)$ is invertible.

(c) To find $f^{-1}(x)$: Interchange x & y

$$\frac{e^y - e^{-y}}{2} = x \Rightarrow e^{2y} - 2xe^y - 1 = 0$$

$$\Rightarrow e^y = \frac{2x \pm \sqrt{4x^2 + 4}}{2} \Rightarrow e^y = x \pm \sqrt{1+x^2}$$

Since $e^y > 0$, hence negative sign is ruled out and

$$\text{Hence } e^y = x + \sqrt{1+x^2}$$

Taking logarithm, we have $y = \ln(x + \sqrt{1+x^2})$ or $f^{-1}(x) = \ln(x + \sqrt{1+x^2})$

Illustration 29: Find the inverse of the function $f(x) = \log_a \left(x + \sqrt{(x^2 + 1)} \right)$; $a > 1$ and assuming it to be an onto function.

Solution : Given $f(x) = \log_a \left(x + \sqrt{x^2 + 1} \right)$

$$\therefore f'(x) = \frac{\log_a e}{\sqrt{1+x^2}} > 0$$

which is a strictly increasing functions.

Thus, $f(x)$ is injective, given that $f(x)$ is onto. Hence the given function $f(x)$ is invertible.

Interchanging x & y

$$\Rightarrow \log_a \left(y + \sqrt{(y)^2 + 1} \right) = x$$

$$\Rightarrow y + \sqrt{(y)^2 + 1} = a^x \quad \dots(\text{i})$$

$$\text{and } \sqrt{(y)^2 + 1} - y = a^{-x} \quad \dots(\text{ii})$$

From (i) and (ii), we get $y = \frac{1}{2}(a^x - a^{-x})$ or $f^{-1}(x) = \frac{1}{2}(a^x - a^{-x})$

Illustration 30: Find the inverse of the function $f(x) = \ln(x^2 + 3x + 1)$; $x \in [1, 3]$ and assuming it to be an onto function.

Solution : Given $f(x) = \ln(x^2 + 3x + 1)$

$$\therefore f'(x) = \frac{2x + 3}{(x^2 + 3x + 1)} > 0 \forall x \in [1, 3]$$

Which is a strictly increasing function. Thus $f(x)$ is injective, given that $f(x)$ is onto. Hence the given function $f(x)$ is invertible.

Interchanging x & y

$$\Rightarrow (y)^2 + 3(y) + 1 - e^x = 0$$

$$\therefore y = \frac{-3 \pm \sqrt{9 - 4 \cdot (1 - e^x)}}{2} = \frac{-3 \pm \sqrt{(5 + 4e^x)}}{2}$$

$$\Rightarrow y = \frac{-3 + \sqrt{(5 + 4e^x)}}{2} \quad (\text{as } y \in [1, 3])$$

$$\text{Hence } f^{-1}(x) = \frac{-3 + \sqrt{(5 + 4e^x)}}{2}$$

Do yourself - 9 :

(i) Let $f: [-1, 1] \rightarrow [-1, 1]$ defined by $f(x) = x|x|$, find $f^{-1}(x)$.

(ii) $f(x) = 1 + \ln(x+2)$, find $f^{-1}(x)$.

15. ODD & EVEN FUNCTIONS :

Consider a function $f(x)$ such that both x and $-x$ are in its domain then

If $\begin{cases} f(-x) = f(x) & \text{then } f \text{ is said to be an even function} \\ f(-x) = -f(x) & \text{then } f \text{ is said to be an odd function} \end{cases}$

Note :

(i) $f(x) - f(-x) = 0 \Rightarrow f(x)$ is even & $f(x) + f(-x) = 0 \Rightarrow f(x)$ is odd.

(ii) A function may neither be odd nor even.

(iii) The only function which is defined on the entire number line & is even and odd at the same time is $f(x) = 0$.

(iv) Every constant function is even function.

(v) Inverse of an even function is not defined.

(vi) Every even function is symmetric about the y-axis & every odd function is symmetric about the origin.

Special Note : If a function $f(x)$ is defined as $f(a+x) = f(a-x)$ then this function is symmetric about line $x = a$

(vii) Every function which has ' $-x$ ' in its domain whenever ' x ' is in its domain, can be expressed as the sum of an even & an odd function .

$$\text{i.e. } f(x) = \underbrace{\frac{f(x) + f(-x)}{2}}_{\text{EVEN}} + \underbrace{\frac{f(x) - f(-x)}{2}}_{\text{ODD}}$$

(viii) If $f(x)$ is odd and defined at $x = 0$, then $f(0) = 0$.

$f(x)$	$g(x)$	$f(x) + g(x)$	$f(x) - g(x)$	$f(x) \cdot g(x)$	$f(x)/g(x)$	$(g \circ f)(x)$	$(f \circ g)(x)$
odd	odd	odd	odd	even	even	odd	odd
even	even	even	even	even	even	even	even
odd	even	neither odd nor even	neither odd nor even	odd	odd	even	even
even	odd	neither odd nor even	neither odd nor even	odd	odd	even	even

Illustration 31 : Which of the following functions is (are) even, odd or neither :

(i) $f(x) = x^2 \sin x$ (ii) $f(x) = \sin x - \cos x$ (iii) $f(x) = \frac{e^x + e^{-x}}{2}$

Solution :

(i) $f(-x) = (-x)^2 \sin(-x) = -x^2 \sin x = -f(x)$. Hence $f(x)$ is odd.

(ii) $f(-x) = \sin(-x) - \cos(-x) = -\sin x - \cos x$.

Hence $f(x)$ is neither even nor odd.

(iii) $f(-x) = \frac{e^{-x} + e^{-(-x)}}{2} = \frac{e^{-x} + e^x}{2} = f(x)$. Hence $f(x)$ is even

Illustration 32: Identify the given functions as odd, even or neither :

(i) $f(x) = \frac{x}{e^x - 1} + \frac{x}{2} + 1$ (ii) $f(x + y) = f(x) + f(y)$ for all $x, y \in \mathbb{R}$

Solution :

(i) $f(x) = \frac{x}{e^x - 1} + \frac{x}{2} + 1$

Clearly domain of $f(x)$ is $\mathbb{R} \sim \{0\}$. We have,

$$\begin{aligned} f(-x) &= \frac{-x}{e^{-x} - 1} - \frac{x}{2} + 1 = \frac{-e^x \cdot x}{1 - e^x} - \frac{x}{2} + 1 = \frac{(e^x - 1 + 1)x}{(e^x - 1)} - \frac{x}{2} + 1 \\ &= x + \frac{x}{e^x - 1} - \frac{x}{2} + 1 = \frac{x}{e^x - 1} + \frac{x}{2} + 1 = f(x) \end{aligned}$$

Hence $f(x)$ is an even function.

(ii) $f(x + y) = f(x) + f(y)$ for all $x, y \in \mathbb{R}$

Replacing x, y by zero, we get $f(0) = 2f(0) \Rightarrow f(0) = 0$

Replacing y by $-x$, we get $f(x) + f(-x) = f(0) = 0 \Rightarrow f(x) = -f(-x)$

Hence $f(x)$ is an odd function.

Do yourself - 10 :

(i) Which of the following functions is (are) even, odd or neither :

(a) $f(x) = x^3 \sin 3x$ (b) $f(x) = \frac{e^{x^2} + e^{-x^2}}{2x}$

(c) $f(x) = \frac{e^x - e^{-x}}{e^x + e^{-x}}$ (d) $f(x) = x^2 + 2^x$

16. PERIODIC FUNCTION :

A function $f(x)$ is called periodic if there exists a positive number T ($T > 0$), where T is the smallest such value called the period of the function such that $f(x+T) = f(x)$, for all values of x , $x+T$ within the domain of f .

Note :

- (i) Odd powers of $\sin x$, $\cos x$, $\sec x$, $\csc x$ are periodic with period 2π .
- (ii) None zero integral powers of $\tan x$, $\cot x$ are periodic with period π .
- (iii) Non zero even powers or modulus of $\sin x$, $\cos x$, $\sec x$, $\csc x$ are periodic with period π .
- (iv) $f(T) = f(0) = f(-T)$, where 'T' is the period.
- (v) if $f(x)$ has a period T then **$f(ax + b)$ has a period $T/|a|$** ($a \neq 0$).

Proof : Let $f(x+T) = f(x)$ and $f[a(x+T') + b] = f(ax+b)$
 $f(ax+b+aT') = f(ax+b)$

$$f(y+aT') = f(y) = f(y+T) \Rightarrow T = aT' \Rightarrow T' = \frac{T}{a}$$

(vi) If $f(x)$ & $g(x)$ are periodic with period T_1 & T_2 respectively, then period of $f(x) \pm g(x)$ is L.C.M. of (T_1, T_2) .

(a) LCM of T_1 & T_2 is defined when T_1/T_2 is rational.

(b) $\text{LCM of } \left\{ \frac{a}{b}, \frac{p}{q} \right\} = \frac{\text{LCM of } (a, p)}{\text{HCF of } (b, q)}$

In case if there exists a finite K such that $K < \text{LCM of } T_1 \text{ and } T_2$ and overall function repeats itself after every K , then period of the function will be K .

- (vii) Every constant function is always periodic, whose period is undefined.
- (viii) Inverse of a periodic function does not exist.

Illustration 33 : Find the periods (if periodic) of the following functions, where $[.]$ denotes the greatest integer function

(i) $f(x) = e^{\ln(\sin x)} + \tan^3 x - \csc(3x - 5)$ (ii) $f(x) = x - [x - b]$, $b \in \mathbb{R}$

(iii) $f(x) = \frac{|\sin x + \cos x|}{|\sin x| + |\cos x|}$ (iv) $f(x) = \tan \frac{\pi}{2} [x]$

(v) $f(x) = \cos(\sin x) + \cos(\cos x)$ (vi) $f(x) = \frac{(1 + \sin x)(1 + \sec x)}{(1 + \cos x)(1 + \csc x)}$

(vii) $f(x) = e^{x - [x] + |\cos \pi x| + |\cos 2 \pi x| + \dots + |\cos n \pi|}$

Solution :

(i) $f(x) = e^{\ln(\sin x)} + \tan^3 x - \csc(3x - 5)$

Period of $e^{\ln \sin x} = 2\pi$, $\tan^3 x = \pi$

$\csc(3x - 5) = \frac{2\pi}{3}$

\therefore Period = 2π

(ii) $f(x) = x - [x - b] = b + \{x - b\}$

\therefore Period = 1

$$(iii) f(x) = \frac{|\sin x + \cos x|}{|\sin x| + |\cos x|}$$

Since period of $|\sin x + \cos x| = \pi$ and period of $|\sin x| + |\cos x|$ is $\frac{\pi}{2}$. Hence $f(x)$ is periodic with π as its period

$$(iv) f(x) = \tan \frac{\pi}{2} [x]$$

$$\tan \frac{\pi}{2} [x + T] = \tan \frac{\pi}{2} [x] \Rightarrow \frac{\pi}{2} [x + T] = n\pi + \frac{\pi}{2} [x]$$

$$\therefore T = 2$$

$$\therefore \text{Period} = 2$$

(v) Let $f(x)$ is periodic then $f(x + T) = f(x)$

$$\Rightarrow \cos(\sin(x + T)) + \cos(\cos(x + T)) = \cos(\sin x) + \cos(\cos x)$$

If $x = 0$ then $\cos(\sin T) + \cos(\cos T)$

$$= \cos(0) + \cos(1) = \cos\left(\cos \frac{\pi}{2}\right) + \cos\left(\sin \frac{\pi}{2}\right)$$

On comparing $T = \frac{\pi}{2}$

$$(vi) f(x) = \frac{(1 + \sin x)(1 + \sec x)}{(1 + \cos x)(1 + \csc x)} = \frac{(1 + \sin x)(1 + \cos x) \sin x}{\cos x (1 + \sin x)(1 + \cos x)}$$

$$\Rightarrow f(x) = \tan x$$

Hence $f(x)$ has period π .

$$(vii) f(x) = e^{x - [x] + |\cos \pi x| + |\cos 2\pi x| + \dots + |\cos n\pi|}$$

Period of $x - [x] = 1$

Period of $|\cos \pi x| = 1$

Period of $|\cos 2\pi x| = \frac{1}{2}$

.....
Period of $|\cos n\pi x| = \frac{1}{n}$

So period of $f(x)$ will be L.C.M. of all period = 1

Illustration 34: Find the periods (if periodic) of the following functions, where $[.]$ denotes the greatest integer function

$$(i) f(x) = e^{x-[x]} + \sin x \quad (ii) f(x) = \sin \frac{\pi x}{\sqrt{2}} + \cos \frac{\pi x}{\sqrt{3}} \quad (iii) f(x) = \sin \frac{\pi x}{\sqrt{3}} + \cos \frac{\pi x}{2\sqrt{3}}$$

Solution :

(i) Period of $e^{x-[x]} = 1$
period of $\sin x = 2\pi$

\therefore L.C.M. of rational and an irrational number does not exist.

\therefore not periodic.

$$(ii) \text{ Period of } \sin \frac{\pi x}{\sqrt{2}} = \frac{2\pi}{\pi/\sqrt{2}} = 2\sqrt{2}$$

$$\text{Period of } \cos \frac{\pi x}{\sqrt{3}} = \frac{2\pi}{\pi/\sqrt{3}} = 2\sqrt{3}$$

\therefore L.C.M. of two different kinds of irrational number does not exist.
 \therefore not periodic.

$$(iii) \text{ Period of } \sin \frac{\pi x}{\sqrt{3}} = \frac{2\pi}{\pi/\sqrt{3}} = 2\sqrt{3}$$

$$\text{Period of } \cos \frac{\pi x}{2\sqrt{3}} = \frac{2\pi}{\pi/2\sqrt{3}} = 4\sqrt{3}$$

\therefore L.C.M. of two similar irrational number exist.

\therefore Periodic with period = $4\sqrt{3}$

Ans.

Do yourself - 11 :

(i) Find the periods (if periodic) of the following functions.

(a) $f(x) = \ln(\cos x) + \tan^3 x$.

(b) $f(x) = e^{x-[x]}$, [.] denotes greatest integer function

(c) $f(x) = \left| \sin \frac{x}{2} \right| + \left| \cos \frac{x}{2} \right|$

17. GENERAL :

If x, y are independent variables, then :

(a) $f(xy) = f(x) + f(y) \Rightarrow f(x) = k \ln x$

(b) $f(xy) = f(x) \cdot f(y) \Rightarrow f(x) = x^n, n \in \mathbb{R}$ or $f(x) = 0$

(c) $f(x + y) = f(x) \cdot f(y) \Rightarrow f(x) = a^{kx}$ or $f(x) = 0$

(d) $f(x + y) = f(x) + f(y) \Rightarrow f(x) = kx$, where k is a constant.

Miscellaneous Illustration :

Illustration 35 : ABCD is a square of side ℓ . A line parallel to the diagonal BD at a distance 'x' from the vertex A cuts two adjacent sides. Express the area of the segment of the square with A at a vertex, as a function of x. Find this area at $x = 1/\sqrt{2}$ and at $x = 2$, when $\ell = 2$.

Solution : There are two different situations

Case-I : when $x = AP \leq OA$, i.e., $x \leq \frac{\ell}{\sqrt{2}}$

$$\text{ar}(\triangle AEF) = \frac{1}{2} x \cdot 2x = x^2 \quad (\because PE = PF = AP = x)$$

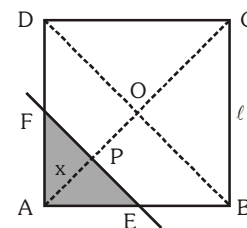

Case-II : when $x = AP > OA$, i.e., $x > \frac{\ell}{\sqrt{2}}$ but $x \leq \sqrt{2}\ell$

$$\text{ar}(\text{ABEFDA}) = \text{ar}(\text{ABCD}) - \text{ar}(\Delta\text{CFE})$$

$$= \ell^2 - \frac{1}{2}(\sqrt{2}\ell - x) \cdot 2(\sqrt{2}\ell - x) \quad [\because \text{CP} = \sqrt{2}\ell - x]$$

$$= \ell^2 - (2\ell^2 + x^2 - 2\sqrt{2}\ell x) = 2\sqrt{2}\ell x - x^2 - \ell^2$$

\therefore the required function $s(x)$ is as follows :

$$s(x) = \begin{cases} x^2, & 0 \leq x \leq \frac{\ell}{\sqrt{2}} \\ 2\sqrt{2}\ell x - x^2 - \ell^2, & \frac{\ell}{\sqrt{2}} < x \leq \sqrt{2}\ell \end{cases} ; \text{ area of } s(x) = \begin{cases} \frac{1}{2} & \text{at } x = \frac{1}{\sqrt{2}} \\ 8(\sqrt{2} - 1) & \text{at } x = 2 \end{cases}$$

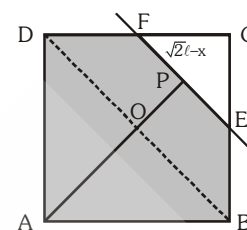

Ans.

Illustration 36 : If the function $f(x)$ satisfies the functional rule, $f(x + y) = f(x) + f(y) \forall x, y \in \mathbb{R}$ & $f(1) = 5$, then find $\sum_{n=1}^m f(n)$.

Solution :

Here, $f(x + y) = f(x) + f(y)$; put $x = t - 1, y = 1$
 $f(t) = f(t - 1) + f(1) \dots(1)$

$\therefore f(t) = f(t - 1) + 5$
 $\Rightarrow f(t) = \{f(t - 2) + 5\} + 5$
 $\Rightarrow f(t) = f(t - 2) + 2(5)$
 $\Rightarrow f(t) = f(t - 3) + 3(5)$

 $\Rightarrow f(t) = f\{t - (t - 1)\} + (t - 1)5$
 $\Rightarrow f(t) = f(1) + (t - 1)5$
 $\Rightarrow f(t) = 5 + (t - 1)5$
 $\Rightarrow f(t) = 5t$

$$\therefore \sum_{n=1}^m f(n) = \sum_{n=1}^m (5n) = 5[1 + 2 + 3 + \dots + m] = \frac{5m(m + 1)}{2}$$

Hence, $\sum_{n=1}^m f(n) = \frac{5m(m + 1)}{2}$.

ANSWERS FOR DO YOURSELF

- 1: (i) (a) $x \in (0, \infty)$ (b) $x \in (-\infty, 0) \cup (4, \infty)$
 (ii) (a) $\left[\frac{1}{2}, \infty\right)$ (b) $[-1, 1]$ (c) $[-2, 2]$ (d) $[-1, 1]$

- 2: (i) (A) $\rightarrow (p, q, r, s)$, (B) $\rightarrow (p)$, (C) $\rightarrow (t)$, (D) $\rightarrow (r)$

- 3: (i) (a) $(-1, 0) \cup (0, 1]$ (b) $\left(-\infty, -\frac{1}{2}\right] \cup (0, 1) \cup (2, \infty)$

- (ii) (a) $(-\infty, \infty)$ (b) $\left[\frac{1}{3}, 1\right]$

- 4: (i) (a) no (b) no (c) yes

- 5: (i) $\left[0, \frac{1}{2}\right]$ (ii) A (iii) (a) $y = \frac{1}{x}$ (b) $y = \frac{1}{x^2}$

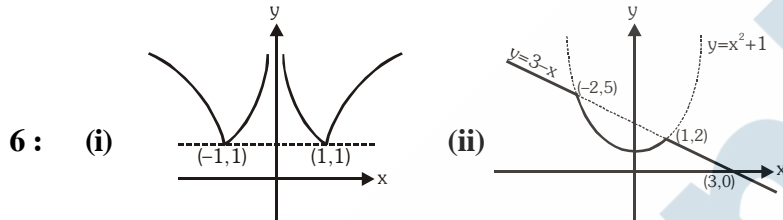

- 7: (i) not onto (ii) yes (iii) B

- 8: (i) (a) 0 (b) 0 (c) 0 (d) 0 (e) 0 (f) 0 (ii)
$$\begin{cases} x+2, & 0 \leq x < 1 \\ x+1, & 1 \leq x < 2 \\ x, & 2 \leq x < 3 \end{cases}$$

- 9: (i) $f^{-1}(x) = \begin{cases} -\sqrt{-x}, & -1 \leq x \leq 0 \\ \sqrt{x}, & 0 \leq x \leq 1 \end{cases}$ (ii) $y = -2 + e^{x-1}$

- 10: (i) (a) even (b) odd (c) odd (d) neither even nor odd

- 11: (i) (a) 2π (b) 1 (c) π

EXERCISE (O-1)

Subjective Type Questions**1. Find the domain of definition of the given functions :**

(i) $y = \sqrt{-px}$ ($p > 0$)

(ii) $y = \frac{1}{x^2 + 1}$

(iii) $y = \frac{1}{x^3 - x}$

(iv) $y = \frac{1}{\sqrt{x^2 - 4x}}$

(v) $y = \sqrt{x^2 - 4x + 3}$

(vi) $y = \frac{x}{\sqrt{x^2 - 3x + 2}}$

(vii) $y = \sqrt{1 - |x|}$

(viii) $y = \log_x 2$

(ix) $y = \frac{1}{\log_{10}(1-x)} + \sqrt{x+2}$

(x) $y = \sqrt{x} + \sqrt[3]{\frac{1}{x-2}} - \log_{10}(2x-3)$

(xi) $y = \frac{3}{4-x^2} + \log_{10}(x^3 - x)$

(xii) $y = \frac{1}{\sqrt{\sin x}} + \sqrt[3]{\sin x}$

(xiii) $y = \log_{10}(\sqrt{x-4} + \sqrt{6-x})$

(xiv) $y = \log_{10}[1 - \log_{10}(x^2 - 5x + 16)]$

2. Find the range of the following functions :

(i) $f(x) = \frac{x-1}{x+2}$

(ii) $f(x) = \frac{2}{x}$

(iii) $f(x) = \frac{1}{x^2 - x + 1}$

(iv) $f(x) = \frac{x^2 - x + 1}{x^2 + x + 1}$

(v) $f(x) = e^{(x-1)^2}$

(vi) $f(x) = x^3 - x^2 + x + 1$

(vii) $f(x) = \log(x^8 + x^4 + x^2 + 1)$

(viii) $f(x) = \sin^2 x - 2\sin x + 4$

(ix) $f(x) = \sin(\log_2 x)$

(x) $f(x) = 2^{x^2} + 1$

(xi) $f(x) = \frac{e^{2x} - e^x + 1}{e^{2x} + e^x + 1}$

(xii) $f(x) = \frac{1}{8 - 3\sin x}$

3. The graph of a function f is given.(a) State the value of $f(-1)$.(b) For what values of x is $f(x) = 2$?(c) State the domain and range of f .(d) On what interval is f increasing?(e) Estimated value of $f(2)$ is -

(A) 2.2

(B) 2.8

(C) 2.5

(D) 3

(f) Estimated value of x such that $f(x) = 0$, is -

(A) -2.5

(B) 0.8

(C) -2.9

(D) 0.3

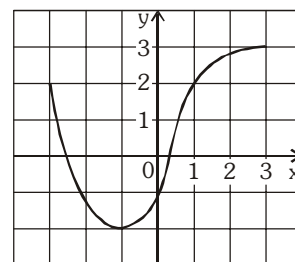
**4. Graph the function $F(x) = \begin{cases} 3-x, & x \leq 1 \\ 2x, & x > 1 \end{cases}$**

5. Find a formula for each function graphed

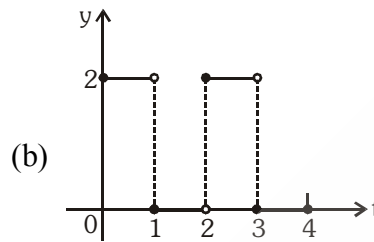
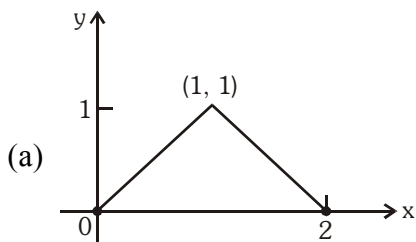

6. The graphs of f and g are given.

- State the value of $f(-4)$ and $g(3)$
- For what value of x is $f(x) = g(x)$?
- Estimate the solution of the equation $f(x) = -1$.
- On what interval is f decreasing?
- State the domain and range of f .
- State the domain and range of g .

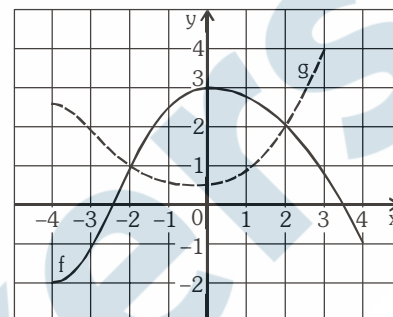

7. Solve the following inequalities using graph of $f(x)$:

- $0 \leq f(x) \leq 1$
- $-1 \leq f(x) \leq 2$
- $2 \leq f(x) \leq 3$
- $f(x) > -1$ & $f(x) < 0$

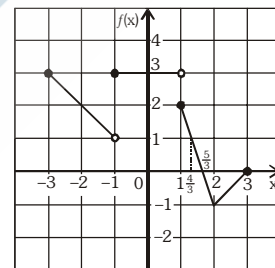

Straight Objective Type

8. If $[a]$ denotes the greatest integer less than or equal to a and $-1 \leq x < 0$, $0 \leq y < 1$, $1 \leq z < 2$, then

$$\begin{vmatrix} [x]+1 & [y] & [z] \\ [x] & [y]+1 & [z] \\ [x] & [y] & [z]+1 \end{vmatrix} \text{ is equal to -}$$

- (A) $[x]$ (B) $[y]$ (C) $[z]$ (D) none of these

9. If $[x]$ and $\{x\}$ denotes the greatest integer function less than or equal to x and fractional part function respectively, then the number of real x , satisfying the equation $(x-2)[x] = \{x\} - 1$, is-

- (A) 0 (B) 1 (C) 2 (D) infinite

10. The range of the function $f(x) = \text{sgn}\left(\frac{\sin^2 x + 2 \sin x + 4}{\sin^2 x + 2 \sin x + 3}\right)$ is (where $\text{sgn}(\cdot)$ denotes signum function)-

- (A) $\{-1, 0, 1\}$ (B) $\{-1, 0\}$ (C) $\{1\}$ (D) $\{0, 1\}$

11. If $2f(x) - 3f\left(\frac{1}{x}\right) = x^2$, x is not equal to zero, then $f(2)$ is equal to-

- (A) $-\frac{7}{4}$ (B) $\frac{5}{2}$ (C) -1 (D) none of these

12. The number of integers lying in the domain of the function $f(x) = \sqrt{\log_{0.5}\left(\frac{5-2x}{x}\right)}$ is -
 (A) 3 (B) 2 (C) 1 (D) 0
13. The range of the function $f: \mathbb{N} \rightarrow \mathbb{I}; f(x) = (-1)^{x-1}$, is -
 (A) $[-1, 1]$ (B) $\{-1, 1\}$ (C) $\{0, 1\}$ (D) $\{0, 1, -1\}$
14. The range of the function $f(x) = e^{-x} + e^x$, is -
 (A) $f(x) \geq 1$ (B) $f(x) \leq 1$ (C) $f(x) \geq 2$ (D) $f(x) \leq 2$
15. If $f(x) = \frac{4^x}{4^x + 2}$, then $f(x) + f(1-x)$ is equal to -
 (A) 0 (B) -1 (C) 1 (D) 4
16. The range of the function $f(x) = \sqrt{4-x^2} + \sqrt{x^2-1}$ is
 (A) $[\sqrt{3}, \sqrt{7}]$ (B) $[\sqrt{3}, \sqrt{5}]$ (C) $[\sqrt{2}, \sqrt{3}]$ (D) $[\sqrt{3}, \sqrt{6}]$
17. A function f has domain $[-1, 2]$ and range $[0, 1]$. The domain and range respectively of the function g defined by $g(x) = 1 - f(x+1)$ is
 (A) $[-1, 1]; [-1, 0]$ (B) $[-2, 1]; [0, 1]$ (C) $[0, 2]; [-1, 0]$ (D) $[1, 3]; [-1, 0]$
18. For the function $f(x) = \frac{e^x + 1}{e^x - 1}$, if $n(d)$ denotes the number of integers which are not in its domain and $n(r)$ denotes the number of integers which are not in its range, then $n(d) + n(r)$ is equal to -
 (A) 2 (B) 3 (C) 4 (D) Infinite
19. If $x^4 f(x) - \sqrt{1 - \sin 2\pi x} = |f(x)| - 2f(x)$, then $f(-2)$ equals
 (A) $\frac{1}{17}$ (B) $\frac{1}{11}$ (C) $\frac{1}{19}$ (D) 0
20. Let $f: \mathbb{R} - \left\{\frac{-15}{2}\right\} \rightarrow \mathbb{R} - \left\{\frac{1}{2}\right\}$ be defined by $f(x) = \frac{x+10}{2x+15}$ then $f(x)$ is -
 (A) one-one but not onto (B) many one but not-onto
 (C) one-one and onto (D) many one and onto
21. $f: \mathbb{R} \rightarrow \mathbb{R}$ $f(x) = \frac{2x^2 - 5x + 3}{8x^2 + 9x + 11}$, then f is -
 (A) one-one onto (B) many-one onto (C) one-one into (D) many one into
22. If $f: \mathbb{R} \rightarrow \mathbb{R}$ & $f(x) = \frac{\sin([x]\pi)}{x^2 + 2x + 3} + 2x - 1 + \sqrt{x(x-1) + \frac{1}{4}}$ (where $[x]$ denotes integral part of x), then $f(x)$ is -
 (A) one-one but not onto (B) one-one & onto
 (C) onto but not one-one (D) neither one-one nor onto

23. Which of the following function is surjective but not injective

- (A) $f: \mathbb{R} \rightarrow \mathbb{R} \quad f(x) = x^4 + 2x^3 - x^2 + 1$ (B) $f: \mathbb{R} \rightarrow \mathbb{R} \quad f(x) = x^3 + x + 1$
 (C) $f: \mathbb{R} \rightarrow \mathbb{R}^+ \quad f(x) = \sqrt{1+x^2}$ (D) $f: \mathbb{R} \rightarrow \mathbb{R} \quad f(x) = x^3 + 2x^2 - x + 1$

24. If $f(x) = x|x|$ then $f^{-1}(x)$ equals-

- (A) $\sqrt{|x|}$ (B) $(\text{sgn } x) \cdot \sqrt{|x|}$ (C) $-\sqrt{|x|}$ (D) Does not exist
 (where $\text{sgn}(x)$ denotes signum function of x)

25. If $f: (-\infty, 3] \rightarrow [7, \infty); f(x) = x^2 - 6x + 16$, then which of the following is true -

- (A) $f^{-1}(x) = 3 + \sqrt{x-7}$ (B) $f^{-1}(x) = 3 - \sqrt{x-7}$
 (C) $f^{-1}(x) = \frac{1}{x^2 - 6x + 16}$ (D) f is many-one

26. $f: \mathbb{R} \rightarrow \mathbb{R}$ such that $f(x) = \ln(x + \sqrt{x^2 + 1})$. Another function $g(x)$ is defined such that $g \circ f(x) = x \quad \forall x \in \mathbb{R}$. Then $g(2)$ is -

- (A) $\frac{e^2 + e^{-2}}{2}$ (B) e^2 (C) $\frac{e^2 - e^{-2}}{2}$ (D) e^{-2}

27. Let $P(x) = kx^3 + 2k^2x^2 + k^3$. The sum of all real numbers k for which $(x-2)$ is a factor of $P(x)$, is
 (A) 4 (B) 8 (C) -4 (D) -8

28. Which of the following is the graph of $y = |x-1| + |x-3|$?

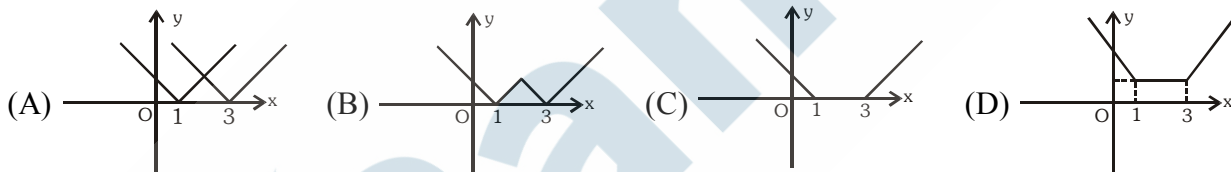

29. Which of the following is the graph of $y = \frac{|\sin x|}{\sin x}$?

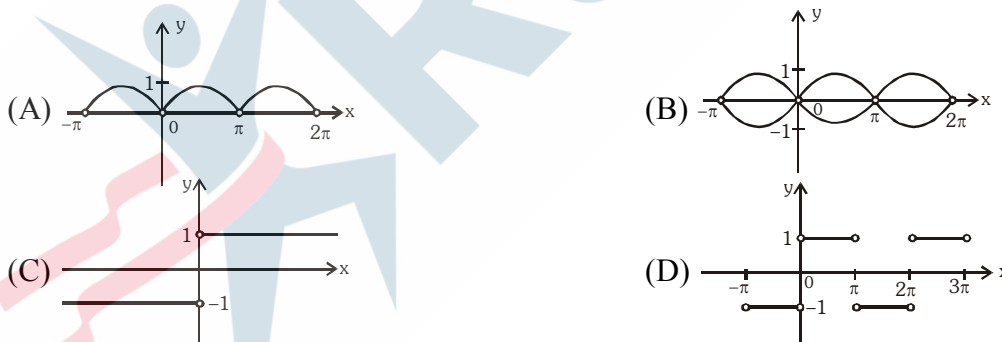

30. Period of function $f(x) = \min\{\sin x, |x|\} + \frac{x}{\pi} - \left[\frac{x}{\pi} \right]$ (where $[.]$ denotes greatest integer function) is -

- (A) $\pi/2$ (B) π (C) 2π (D) 4π

Multiple Correct Answer

31. Which of the following function(s) have the same domain and range ?

- (A) $f(x) = \sqrt{1-x^2}$ (B) $g(x) = \frac{1}{x}$ (C) $h(x) = \sqrt{x}$ (D) $l(x) = \sqrt{4-x}$

32. Let $f(x) = x^2 + 3x + 2$, then number of solutions to -
 (A) $f(|x|) = 2$ is 1 (B) $f(x) = 2$ is 3 (C) $|f(x)| = 0.125$ is 4 (D) $|f(|x|)| = 0.125$ is 8
33. Which of the following pair(s) of function have same graphs?

(A) $f(x) = \frac{\sec x}{\cos x} - \frac{\tan x}{\cot x}$, $g(x) = \frac{\cos x}{\sec x} + \frac{\sin x}{\operatorname{cosec} x}$

(B) $f(x) = \operatorname{sgn}(x^2 - 4x + 5)$, $g(x) = \operatorname{sgn}\left(\cos^2 x + \sin^2\left(x + \frac{\pi}{3}\right)\right)$ where sgn denotes signum function.

(C) $f(x) = e^{\ln(x^2 + 3x + 3)}$, $g(x) = x^2 + 3x + 3$

(D) $f(x) = \frac{\sin x}{\sec x} + \frac{\cos x}{\operatorname{cosec} x}$, $g(x) = \frac{2\cos^2 x}{\cot x}$

34. If a function is defined by an implicit equation $2^{|x|+|y|} + 2^{|x|-|y|} = 2$, then -

- (A) Domain of function is singleton
 (B) Range of function is singleton
 (C) graph of the function intersects the line $y = x$
 (D) maximum value of function is 2

35. For each real x , let $f(x) = \max\{x, x^2, x^3, x^4\}$, then $f(x)$ is -

(A) x^4 for $x \leq -1$ (B) x^2 for $-1 < x \leq 0$ (C) $f\left(\frac{1}{2}\right) = \frac{1}{2}$ (D) $f\left(\frac{1}{2}\right) = \frac{1}{4}$

36. Let $f(x) = \sin^6 x + \cos^6 x$, then -

- (A) $f(x) \in [0, 1] \forall x \in \mathbb{R}$ (B) $f(x) = 0$ has no solution
 (C) $f(x) \in \left[\frac{1}{4}, 1\right] \forall x \in \mathbb{R}$ (D) $f(x)$ is an injective function

37. Let $f(x) = \begin{cases} x^2 - 3x + 4 & ; x < 3 \\ x + 7 & ; x \geq 3 \end{cases}$ and $g(x) = \begin{cases} x + 6 & ; x < 4 \\ x^2 + x + 2 & ; x \geq 4 \end{cases}$, then which of the following is/are true -

(A) $(f + g)(1) = 9$ (B) $(f - g)(3.5) = 1$ (C) $(f \cdot g)(0) = 24$ (D) $\left(\frac{f}{g}\right)(5) = \frac{8}{3}$

Matrix Match Type

38. Match the functions given in column-I correctly with mappings given in column-II.

Column-I

(A) $f: \left[-\frac{1}{2}, \frac{1}{2}\right] \rightarrow \left[\frac{4}{7}, \frac{4}{3}\right]$

$f(x) = \frac{1}{x^2 + x + 1}$

(B) $f: [-2, 2] \rightarrow [-1, 1]$

$f(x) = \sin x$

(C) $f: \mathbb{R} - \mathbb{I} \rightarrow \mathbb{R}$

$f(x) = \ell n\{x\}$, (where $\{.\}$ represents fractional part function)

(D) $f: (-\infty, 0] \rightarrow [1, \infty)$, $f(x) = (1 + \sqrt{-x}) + (\sqrt{-x} - x)$

Column-II

(P) Injective mapping

(Q) Non-injective mapping

(R) Surjective mapping

(S) Non-surjective mapping

(T) Bijective mapping

Linked Comprehension Type

Paragraph for Question 39 & 40

$$\text{Let } f(x) = \begin{cases} x & ; x < 0 \\ 1-x & ; x \geq 0 \end{cases} \quad \& \quad g(x) = \begin{cases} x^2 & ; x < -1 \\ 2x+3 & ; -1 \leq x \leq 1 \\ x & ; x > 1 \end{cases}$$

On the basis of above information, answer the following questions :

39. Range of $f(x)$ is -
(A) $(-\infty, 1]$ (B) $(-\infty, \infty)$ (C) $(-\infty, 0]$ (D) $(-\infty, 2]$
40. Range of $g(f(x))$ is -
(A) $(-\infty, \infty)$ (B) $[1, 3) \cup (3, \infty)$ (C) $[1, \infty)$ (D) $[0, \infty)$

EXERCISE (O-2)

Straight Objective Type

1. The number of integral values of x satisfying the inequality $[x-5][x-3]+2 < [x-5]+2[x-3]$ (where $[.]$ represents greatest integer function) is -
(A) 0 (B) 1 (C) 2 (D) 3
2. Range of function $f(x) = \log_2 \left(\frac{4}{\sqrt{x+2} + \sqrt{2-x}} \right)$ is given by
(A) $(0, \infty)$ (B) $\left[\frac{1}{2}, 1\right]$ (C) $[1, 2]$ (D) $\left[\frac{1}{4}, 1\right]$
3. A lion moves in the region given by the graph $y - |y| - x + |x| = 0$. Then on which of the following curve a person can move so that he does not encounter lion -
(A) $y = e^{-|x|}$ (B) $y = \frac{1}{x}$ (C) $y = \text{signum}(x)$ (D) $y = -|4 + |x||$
4. Suppose, $f(x, n) = \sum_{k=1}^n \log_x \left(\frac{k}{x} \right)$, then the value of x satisfying the equation $f(x, 10) = f(x, 11)$, is
(A) 9 (B) 10 (C) 11 (D) none
5. Range of $f(x) = \frac{\sec x + \tan x - 1}{\tan x - \sec x + 1}$; $x \in \left(0, \frac{\pi}{2}\right)$ is -
(A) $(0, 1)$ (B) $(1, \infty)$ (C) $(-1, 0)$ (D) $(-\infty, -1)$
6. If $f(x, y) = \max(x, y) + \min(x, y)$ and $g(x, y) = \max(x, y) - \min(x, y)$, then the value of $f\left(g\left(-\frac{2}{3}, -\frac{3}{2}\right), g(-3, -4)\right)$ is greater than -
(A) 1 (B) 2 (C) 3 (D) 4

7. If functions $f(x)$ and $g(x)$ are defined on $\mathbb{R} \rightarrow \mathbb{R}$ such that $f(x) = \begin{cases} x+3 & , x \in \text{rational} \\ 4x & , x \in \text{irrational} \end{cases}$,

$$g(x) = \begin{cases} x + \sqrt{5} & , x \in \text{irrational} \\ -x & , x \in \text{rational} \end{cases} \text{ then } (f - g)(x) \text{ is-}$$

- (A) one-one & onto (B) neither one-one nor onto
(C) one-one but not onto (D) onto but not one-one
8. Let $f: A \rightarrow B$ be an onto function such that $f(x) = \sqrt{x-2-2\sqrt{x-3}} - \sqrt{x-2+2\sqrt{x-3}}$, then set 'B' is-

- (A) $[-2,0]$ (B) $[0,2]$ (C) $[-3,0]$ (D) $[-1,0]$

9. Let $f(x) = \frac{x}{1-x}$ and let α be a real number. If $x_0 = \alpha, x_1 = f(x_0), x_2 = f(x_1), \dots$ & $x_{2011} = -\frac{1}{2012}$ then the value of α is -

- (A) $\frac{2011}{2012}$ (B) 1 (C) 2011 (D) -1

10. If $f_1(x) = 2^{f_2(x)}$, where $f_2(x) = 2012^{f_3(x)}$, where $f_3(x) = \left(\frac{1}{2013}\right)^{f_4(x)}$, where $f_4(x) = \log_{2013} \log_x 2012$, then the range of $f_1(x)$ is -

- (A) $(2, \infty)$ (B) $(2012, \infty)$ (C) $(0, \infty)$ (D) $(-\infty, \infty)$

11. Let $f: \mathbb{R} \rightarrow \mathbb{R}$ be defined by $f(x) = \ln(x + \sqrt{x^2 + 1})$, then number of solutions of $|f^{-1}(x)| = e^{-|x|}$ is :-

- (A) 1 (B) 2 (C) 3 (D) Infinite

12. $f(x) = [x-1] + \{x\}^{[x]}$, $x \in (1,3)$, then $f^{-1}(x)$ is -

(where $[.]$ denotes greatest integer function and $\{.\}$ denotes fractional part function)

(A) $\begin{cases} x+1 & x \in (1,2) \\ 2+\sqrt{x-1} & x \in [2,3) \end{cases}$ (B) $\begin{cases} x-1 & x \in (1,2) \\ 2-\sqrt{x-1} & x \in [2,3) \end{cases}$

(C) $\begin{cases} x-1 & x \in (0,1) \\ 2-\sqrt{x-1} & x \in [1,2) \end{cases}$ (D) $\begin{cases} x+1 & x \in (0,1) \\ 2+\sqrt{x-1} & x \in [1,2) \end{cases}$

13. Let $f: \mathbb{R} \rightarrow \mathbb{R}$ and $f(x) = x^3 + ax^2 + bx - 8$. If $f(x) = 0$ has three real roots & $f(x)$ is a bijective function, then $(a+b)$ is equal to

- (A) 0 (B) 6 (C) -6 (D) 12

14. Which of the following functions is an odd function ?

(A) $|x-2| + (x+2) \operatorname{sgn}(x+2)$ (B) $\frac{1}{x(e^x-1)} + \frac{1}{2x}$

(C) $\log(\sin x + \sqrt{1+\sin^2 x})$ (D) $e^{-4x} (e^{2x} - 1)^4$

(where $\operatorname{sgn}(x)$ denotes signum function of x)

15. Period of $f(x) = \{x\} + \left\{x + \frac{1}{3}\right\} + \left\{x + \frac{2}{3}\right\}$ is equal to (where $\{.\}$ denotes fractional part function)
- (A) 1 (B) $\frac{2}{3}$ (C) $\frac{1}{2}$ (D) $\frac{1}{3}$
16. Let $f(x) = 2x - \left\{\frac{x}{\pi}\right\}$ and $g(x) = \cos x$, where $\{.\}$ denotes fractional part function, then period of $g \circ f(x)$ is -
- (A) $\frac{\pi}{2}$ (B) π (C) $\frac{3\pi}{2}$ (D) $\frac{\pi}{4}$
17. The period of the function $\frac{\sin x + \sin 5x}{\cos x + \cos 5x}$ is -
- (A) $\frac{\pi}{3}$ (B) $\frac{\pi}{2}$ (C) π (D) 2π
18. Let $f : \mathbb{R} \rightarrow \mathbb{R}$ be a real valued function such that $f(10 + x) = f(10 - x) \forall x \in \mathbb{R}$ and $f(20 + x) = -f(20 - x) \forall x \in \mathbb{R}$. Then which of the following statements is true -
- (A) $f(x)$ is odd and periodic (B) $f(x)$ is odd and aperiodic
(C) $f(x)$ is even and periodic (D) $f(x)$ is even and aperiodic

Multiple Correct Answer Type

19. Let $f(x) = \begin{cases} x^2 & ; 0 < x < 2 \\ 2x - 3 & ; 2 \leq x < 3 \\ x + 2 & ; x \geq 3 \end{cases}$ Then :-
- (A) $f\left\{f\left(f\left(\frac{3}{2}\right)\right)\right\} = f\left(\frac{3}{2}\right)$ (B) $1 + f\left\{f\left(f\left(\frac{5}{2}\right)\right)\right\} = f\left(\frac{5}{2}\right)$
(C) $f\{f(1)\} = f(1) = 1$ (D) none of these
20. The range of the function $f(\theta) = \sqrt{8\sin^2 \theta + 4\cos^2 \theta - 8\sin \theta \cos \theta}$ is -
- (A) $[\sqrt{5} - 1, \sqrt{5} + 1]$ (B) $[0, \sqrt{5} + 1]$
(C) $[\sqrt{6 - \sqrt{20}}, \sqrt{6 + \sqrt{20}}]$ (D) none of these
21. For the function $f(x) = |x + 3| - |x + 1| - |x - 1| + |x - 3|$, identify correct option(s)
- (A) Range of $f(x)$ is $(-\infty, 4]$ (B) maximum value of $f(x)$ is 4
(C) $f(x) = 4$ has infinite solutions (D) $f(x) = 0$ has infinite solutions
22. If $\{x\} = \frac{2}{3}$ & $\left[x + \left\{x + \left[x + \left\{x + \dots \dots 100 \text{ times} \right\}\right]\right\}\right] = 5$, then -
- (A) $x = \frac{14}{3}$ (B) $[x] = 5$ (C) $x = \frac{17}{3}$ (D) $[x] = 4$
(where $[.]$ & $\{.\}$ denotes greatest integer function & fractional part function respectively)

23. The values of x in $[-2\pi, 2\pi]$, for which the graph of the function $y = \sqrt{\frac{1+\sin x}{1-\sin x}} - \sec x$ and

$$y = -\sqrt{\frac{1-\sin x}{1+\sin x}} + \sec x, \text{ coincide are}$$

- (A) $\left[-2\pi, -\frac{3\pi}{2}\right] \cup \left[\frac{3\pi}{2}, 2\pi\right]$ (B) $\left(-\frac{3\pi}{2}, -\frac{\pi}{2}\right) \cup \left(\frac{\pi}{2}, \frac{3\pi}{2}\right)$
 (C) $\left(-\frac{\pi}{2}, \frac{\pi}{2}\right)$ (D) $[-2\pi, 2\pi] - \left\{\pm\frac{\pi}{2}, \pm\frac{3\pi}{2}\right\}$
24. A parabola of the form $y = ax^2 + bx + c$ with $a > 0$ intersects the graph of $f(x) = \frac{1}{x^2 - 4}$. Number of possible distinct intersection(s) of these graph is
 (A) 0 (B) 2 (C) 3 (D) 4
25. Let $f: \{1,2,3,4,5\} \rightarrow \{1,2,3,4,5\}$ is such that $f(x)$ is a one-one function satisfying following condition $f(x) = x + 1$ **if and only if** x is even (i.e. $f(3) \neq 4, f(4) = 5$ etc). Then $f^{-1}(2)$ can be
 (A) 1 (B) 3 (C) 5 (D) 2
26. Which of the following statement(s) is(are) correct ?
 (A) If f is a one-one mapping from set A to A , then f is onto.
 (B) If f is an onto mapping from set A to A , then f is one-one
 (C) Let f and g be two functions defined from $\mathbb{R} \rightarrow \mathbb{R}$ such that $g \circ f$ is injective, then f must be injective.
 (D) If set A contains 3 elements while set B contains 2 elements, then total number of functions from A to B is 8.
27. If $f(x) = ax + b$ and $f(f(f(x))) = 27x + 13$ where a and b are real numbers, then-
 (A) $a + b = 3$ (B) $a + b = 4$ (C) $f'(x) = 3$ (D) $f'(x) = -3$
28. Given $f(1) = 2$ and $f(n+1) = \frac{f(n)-1}{f(n)+1} \forall n \in \mathbb{N}$, then-
 (A) $f(2015) = -\frac{1}{2}$ (B) $(f(2012))^{f(2013)} = 9$
 (C) $f(1001) = 2$ (D) $f(2015) = -3$
29. Which of the following is/are true?
 (A) $f(x) = e^x$ and $g(x) = \ln x$, then $f(g(x)) = x$ (wherever $f(g(x))$ is defined)
 (B) $f(x) = \frac{2+x}{3-x}$ and $g(x) = \frac{(3x-2)}{(x+1)}$, then $f(g(x)) = x$ (wherever $f(g(x))$ is defined)
 (C) $f(x) = 4x + 7$ and $g(x) = \frac{(x-7)}{4}$, then $f(g(x)) = x$ (wherever $f(g(x))$ is defined)
 (D) $f(x) = x^3 + 1$ and $g(x) = (x-1)^{1/3}$, then $f(g(x)) = x$ (wherever $f(g(x))$ is defined)

30. If $g(x) = x^2 - x + 1$ and $f(x) = \sqrt{\frac{1}{x} - x}$, then -

- (A) Domain of $f(g(x))$ is $[0,1]$ (B) Range of $f(g(x))$ is $\left(0, \frac{7}{2\sqrt{3}}\right]$
 (C) $f(g(x))$ is many-one function (D) $f(g(x))$ is unbounded function

Linked Comprehension Type

Paragraph for Question 31 to 33

$$f(x) = \frac{x^2 + 1}{ax} \quad (a \neq 0); \quad g(x) = 3 \sec x; \quad h(x) = \frac{x + 3}{x - 4}$$

On the basis of above information, answer the following questions :

31. If range of $f(x)$ and $g(x)$ are equal sets then 'a' is equal to -
 (A) 3 (B) -2/3 (C) 3/2 (D) -3/2
32. $f(x)$ is one-one if-
 (A) $x \in (0, \infty)$ (B) $x \in (-\infty, 0)$ (C) $x \in (1, \infty)$ (D) $x \in (-\infty, 1) - \{0\}$
33. Which the following is always false ?
 (A) $h(x)$ is one-one
 (B) $f(x)$ is one-one if $x > 10$
 (C) $g(x)$ is many-one if $x \in \left(0, \frac{\pi}{2}\right) \cup \left(\frac{\pi}{2}, 3\right)$
 (D) The values of k for which $f(x) = k$ has exactly one solution is $k = 2$ or $k = -2$

Matrix Match Type

34. **Column-I** **Column-II**
Number of integers in
- (A) Domain of $f(x) = \ln\{x\}$ (P) 0
 (B) Domain of $f(x) = \sqrt{\sec(\sin x)} + \sqrt{\left[x + \frac{1}{x}\right]} + \sqrt{10 - [x]^2}$ (Q) 2
 (C) Range of $f(x) = x^2 - 2x + 2, x \in [0, 2]$ (R) 3
 (D) Range of $f(x) = \sqrt{25 - [x]^2}$ (S) less than 3
 (T) more than 3

(where $[.]$ and $\{.\}$ denote greatest integer function and fractional part function respectively)

35. Match the function mentioned in column-I with the respective classification given in column-II.
 (where $[.]$ and $\{.\}$ denote greatest integer function and fractional part function respectively)

- Column-I** **Column-II**
- (A) $f: \mathbb{R} \rightarrow \mathbb{R}^+ \quad f(x) = (e^{[x]})(e^{\{x\}})$ (P) one-one
 (B) $f: (-\infty, -2) \cup (0, \infty) \rightarrow \mathbb{R} \quad f(x) = \ln(x^2 + 2x)$ (Q) many-one
 (C) $f: [-2, 2] \rightarrow [-1, 1] \quad f(x) = \sin x$ (R) onto
 (D) $f: \mathbb{R} \rightarrow \mathbb{R} \quad f(x) = x^3 - 3x^2 + 3x - 7$ (S) periodic
 (T) aperiodic

EXERCISE (S-1)

1. Find the domains of definitions of the following functions :

(Read the symbols $[*]$ and $\{*\}$ as greatest integers and fractional part functions respectively.)

(i) $f(x) = \sqrt{\cos 2x} + \sqrt{16 - x^2}$ (ii) $f(x) = \log_7 \log_5 \log_3 \log_2 (2x^3 + 5x^2 - 14x)$

(iii) $f(x) = \ln(\sqrt{x^2 - 5x - 24} - x - 2)$ (iv) $f(x) = \sqrt{\frac{1 - 5^x}{7^{-x} - 7}}$

(v) $y = \log_{10} \sin(x - 3) + \sqrt{16 - x^2}$ (vi) $f(x) = \log_{100x} \left(\frac{2 \log_{10} x + 1}{-x} \right)$

(vii) $f(x) = \sqrt{x^2 - |x|} + \frac{1}{\sqrt{9 - x^2}}$ (viii) $f(x) = \sqrt{(x^2 - 3x - 10) \ln^2(x - 3)}$

(ix) $f(x) = \sqrt{(5x - 6 - x^2) [\{\ln\{x\}\}]} + \sqrt{(7x - 5 - 2x^2)} + \left(\ln \left(\frac{7}{2} - x \right) \right)^{-1}$

(x) $f(x) = \log_{\left[\frac{x+1}{x} \right]} \left| x^2 - x - 6 \right| + {}^{16-x}C_{2x-1} + {}^{20-3x}P_{2x-5}$

2. Find the domain & range of the following functions.

(i) $y = \log_{\sqrt{5}} (\sqrt{2} (\sin x - \cos x) + 3)$ (ii) $y = \frac{2x}{1+x^2}$ (iii) $f(x) = \frac{x^2 - 3x + 2}{x^2 + x - 6}$

(iv) $f(x) = \frac{x}{1+|x|}$ (v) $y = \sqrt{2-x} + \sqrt{1+x}$ (vi) $f(x) = \frac{\sqrt{x+4} - 3}{x-5}$

3. (a) Draw graphs of the following function, where $[]$ denotes the greatest integer function.

(i) $f(x) = x + [x]$

(ii) $y = (x)^{[x]}$ where $x = [x] + \{x\}$ & $x > 0$ & $x \leq 3$

(iii) $y = \operatorname{sgn}[x]$

(iv) $\operatorname{sgn}(x - |x|)$

(b) Identify the pair(s) of functions which are identical ?

(where $[x]$ denotes greatest integer and $\{x\}$ denotes fractional part function)

(i) $f(x) = \operatorname{sgn}(x^2 - 3x + 4)$ and $g(x) = e^{[x]}$ (ii) $f(x) = \sqrt{\frac{1 - \cos 2x}{1 + \cos 2x}}$ and $g(x) = \tan x$

(iii) $f(x) = \ln(1+x) + \ln(1-x)$ and $g(x) = \ln(1-x^2)$ (iv) $f(x) = \frac{\cos x}{1 - \sin x}$ and $g(x) = \frac{1 + \sin x}{\cos x}$

4. Classify the following functions $f(x)$ defined in $\mathbb{R} \rightarrow \mathbb{R}$ as injective, surjective, both or none.

(a) $f(x) = \frac{x^2 + 4x + 30}{x^2 - 8x + 18}$ (b) $f(x) = x^3 - 6x^2 + 11x - 6$ (c) $f(x) = (x^2 + x + 5)(x^2 + x - 3)$

5. Solve the following problems from (a) to (d) on functional equation :

(a) The function $f(x)$ defined on the real numbers has the property that $f(f(x)) \cdot (1 + f(x)) = -f(x)$ for all x in the domain of f . If the number 3 is in the domain and range of f , compute the value of $f(3)$.

(b) Suppose f is a real function satisfying $f(x + f(x)) = 4f(x)$ and $f(1) = 4$. Find the value of $f(21)$.

(c) Let f be function defined from $\mathbb{R}^+ \rightarrow \mathbb{R}^+$. If $[f(xy)]^2 = x(f(y))^2$ for all positive numbers x and y and $f(2) = 6$, find the value of $f(50)$.

(d) Let f be a function such that $f(3) = 1$ and $f(3x) = x + f(3x - 3)$ for all x . Then find the value of $f(300)$.

6. Suppose $f(x) = \sin x$ and $g(x) = 1 - \sqrt{x}$. Then find the domain and range of the following functions.
 (a) $f \circ g$ (b) $g \circ f$ (c) $f \circ f$ (d) $g \circ g$

7. A function $f : \mathbb{R} \rightarrow \mathbb{R}$ is such that $f\left(\frac{1-x}{1+x}\right) = x$ for all $x \neq -1$. Prove the following.

(a) $f(f(x)) = x$ (b) $f(1/x) = -f(x)$, $x \neq 0$ (c) $f(-x - 2) = -f(x) - 2$.

8. (a) Find the formula for the function $f \circ g \circ h$, given $f(x) = \frac{x}{x+1}$; $g(x) = x^{10}$ and $h(x) = x + 3$. Find also the domain of this function. Also compute $(f \circ g \circ h)(-1)$.

(b) If $f(x) = \max(x, 1/x)$ for $x > 0$ where $\max(a, b)$ denotes the greater of the two real numbers a and b . Define the function $g(x) = f(x) f(1/x)$ and plot its graph.

9. Let f be a one-one function with domain $\{x, y, z\}$ and range $\{1, 2, 3\}$. It is given that exactly one of the following statements is true and the remaining two are false.

$f(x) = 1$; $f(y) \neq 1$; $f(z) \neq 2$. Determine $f^{-1}(1)$

10. $f(x) = \begin{cases} 1-x & \text{if } x \leq 0 \\ x^2 & \text{if } x > 0 \end{cases}$ and $g(x) = \begin{cases} -x & \text{if } x < 1 \\ 1-x & \text{if } x \geq 1 \end{cases}$ find $(f \circ g)(x)$ and $(g \circ f)(x)$.

11. Find whether the following functions are even or odd or none :

(a) $f(x) = \log(x + \sqrt{1+x^2})$ (b) $f(x) = \frac{x(a^x + 1)}{a^x - 1}$ (c) $f(x) = \sin x + \cos x$

(d) $f(x) = x \sin^2 x - x^3$ (e) $f(x) = \sin x - \cos x$ (f) $f(x) = \frac{(1+2^x)^2}{2^x}$

(g) $f(x) = \frac{x}{e^x - 1} + \frac{x}{2} + 1$ (h) $f(x) = [(x+1)^2]^{1/3} + [(x-1)^2]^{1/3}$

12. (i) Write explicitly, functions of y defined by the following equations and also find the domains of definition of the given implicit functions :

(a) $10^x + 10^y = 10$ (b) $x + |y| = 2y$

(ii) The function $f(x)$ is defined on the interval $[0, 1]$. Find the domain of definition of the functions.

(a) $f(\sin x)$ (b) $f(2x + 3)$

(iii) Given that $y = f(x)$ is a function whose domain is $[4, 7]$ and range is $[-1, 9]$. Find the range and domain of

(a) $g(x) = \frac{1}{3} f(x)$ (b) $h(x) = f(x - 7)$

13. Compute the inverse of the functions :

(a) $f(x) = \ln(x + \sqrt{x^2 + 1})$ (b) $f(x) = 2^{\frac{x}{x-1}}$ (c) $y = \frac{10^x - 10^{-x}}{10^x + 10^{-x}}$

14. Find the inverse of $f(x) = 2^{\log_{10} x} + 8$ and hence solve the equation $f(x) = f^{-1}(x)$.
15. (a) Function f & g are defined by $f(x) = \sin x, x \in \mathbb{R}; g(x) = \tan x, x \in \mathbb{R} - \left(K + \frac{1}{2}\right)\pi$ where $K \in \mathbb{I}$. Find (i) periods of $f \circ g$ & $g \circ f$ (ii) range of the function $f \circ g$ & $g \circ f$
 (b) Suppose that f is an even, periodic function with period 2, and that $f(x) = x$ for all x in interval $[0, 1]$. Find the value of $f(3.14)$.
16. The graph of the function $y = f(x)$ is as follows :

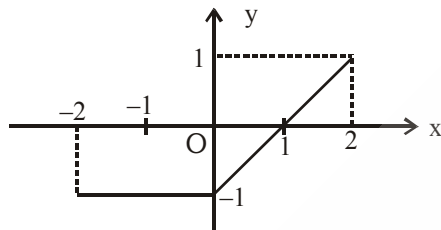

Match the function mentioned in **Column-I** with the respective graph given in **Column-II**.

Column-I

(A) $y = |f(x)|$

(B) $y = f(|x|)$

(C) $y = f(-|x|)$

(D) $y = \frac{1}{2}(|f(x)| - f(x))$

Column-II

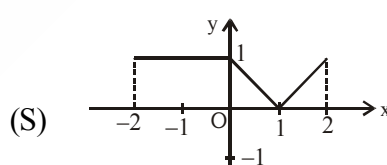
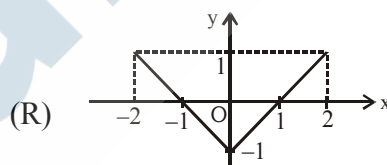
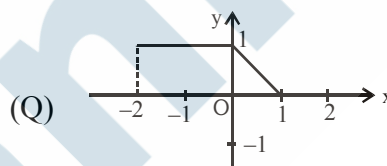
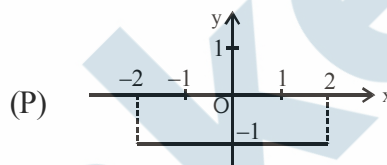

17. **Column-I**

f(x)

(A) $\frac{\cos^2 x + \cos x + 2}{\cos^2 x + \cos x + 1}$

(B) $\left| \frac{(\sqrt{\cos x} - \sqrt{\sin x})(\sqrt{\cos x} + \sqrt{\sin x})}{3(\cos x + \sin x)} \right|$

(C) $\frac{7}{3(x^6 + 2x^4 + 3x^2 + 1)}$

(D) $\log_8(x^2 + 2x + 2)$

Column-II

Range

(P) $\left(0, \frac{7}{3}\right]$

(Q) $\left[\frac{4}{3}, \frac{7}{3}\right]$

(R) $\left[0, \frac{1}{3}\right]$

(S) $[0, \infty)$

18. The sum of integral values of the elements in the domain of $f(x) = \sqrt{\log_{\frac{1}{2}} |3-x|}$ is
19. Number of integers in range of $f(x) = x(x+2)(x+4)(x+6) + 7$, $x \in [-4, 2]$ is
20. The number of even integral value(s) in the range of the function $f(x) = \frac{\tan^2 x + 8 \tan x + 15}{1 + \tan^2 x}$ is
21. If $f(x) = a \log\left(\frac{1+x}{1-x}\right) + bx^3 + c \sin x + 5$ and $f(\log_3 2) = 4$, then $f\left(\log_3\left(\frac{1}{2}\right)\right)$ is equal to
22. Let $P(x) = x^4 + ax^3 + bx^2 + cx + d$ be a polynomial such that $P(1) = 1, P(2) = 8, P(3) = 27, P(4) = 64$, then find $P(10)$.
23. If $f(x) = \begin{cases} 0 & x < 1 \\ 2x - 2 & x \geq 1 \end{cases}$; then the number of solutions of the equation $f(f(f(x))) = x$ is
24. Let 'f' be an even periodic function with period '4' such that $f(x) = 2^x - 1, 0 \leq x \leq 2$.
The number of solutions of the equation $f(x) = 1$ in $[-10, 20]$ are
25. Let $f(x) = \frac{2x-1}{x+3}$. If $f^{-1} = \frac{ax+b}{c-x}$, then $a + b + c$ is
26. Let $f(x)$ be a periodic function with period 'p' satisfying $f(x) + f(x+3) + f(x+6) + \dots + f(x+42) = \text{constant} \forall x \in \mathbb{R}$, then sum of digits of 'p' is

EXERCISE (S-2)

1. Find the domains of definitions of the following functions :
(Read the symbols $[*]$ as greatest integers function)
- (i) $f(x) = \sqrt{\log_x(\cos 2\pi x)}$ (ii) $f(x) = \frac{[x]}{2x - [x]}$
2. (a) Let $P(x) = x^6 + ax^5 + bx^4 + cx^3 + dx^2 + ex + f$ be a polynomial such that
 $P(1) = 1; P(2) = 2; P(3) = 3; P(4) = 4; P(5) = 5$ and $P(6) = 6$, then find the value of $P(7)$.
- (b) Let a and b be real numbers and let $f(x) = a \sin x + b\sqrt[3]{x} + 4, \forall x \in \mathbb{R}$. If $f(\log_{10}(\log_3 10)) = 5$ then find the value of $f(\log_{10}(\log_3 3))$.
3. Suppose $p(x)$ is a polynomial with integer coefficients. The remainder when $p(x)$ is divided by $x - 1$ is 1 and the remainder when $p(x)$ is divided by $x - 4$ is 10. If $r(x)$ is the remainder when $p(x)$ is divided by $(x-1)(x-4)$, find the value of $r(2006)$.

4. A function f , defined for all $x, y \in \mathbb{R}$ is such that $f(1) = 2$; $f(2) = 8$ & $f(x + y) - kxy = f(x) + 2y^2$, where k is some constant. Find $f(x)$ & show that :

$$f(x+y)f\left(\frac{1}{x+y}\right) = k \text{ for } x + y \neq 0.$$

5. If $f(x) = -1 + |x - 2|$, $0 \leq x \leq 4$
 $g(x) = 2 - |x|$, $-1 \leq x \leq 3$

Then find $f \circ g(x)$ & $g \circ f(x)$. Draw rough sketch of the graphs of $f \circ g(x)$ & $g \circ f(x)$.

6. Let $f(x) = x^{135} + x^{125} - x^{115} + x^5 + 1$. If $f(x)$ is divided by $x^3 - x$ then the remainder is some function of x say $g(x)$. Find the value of $g(10)$.
7. Let $\{x\}$ & $[x]$ denote the fractional and integral part of a real number x respectively. Solve $4\{x\} = x + [x]$.
8. Let $f(x) = \frac{9^x}{9^x + 3}$ then find the value of the sum $f\left(\frac{1}{2006}\right) + f\left(\frac{2}{2006}\right) + f\left(\frac{3}{2006}\right) + \dots + f\left(\frac{2005}{2006}\right)$
9. Let $f(x) = (x + 1)(x + 2)(x + 3)(x + 4) + 5$ where $x \in [-6, 6]$. If the range of the function is $[a, b]$ where $a, b \in \mathbb{N}$ then find the value of $(a + b)$.
10. The set of real values of 'x' satisfying the equality $\left[\frac{3}{x}\right] + \left[\frac{4}{x}\right] = 5$ (where $[]$ denotes the greatest integer function) belongs to the interval $\left[a, \frac{b}{c}\right]$ where $a, b, c \in \mathbb{N}$ and $\frac{b}{c}$ is in its lowest form. Find the value of $a + b + c + abc$.
11. $f(x)$ and $g(x)$ are linear function such that for all x , $f(g(x))$ and $g(f(x))$ are Identity functions. If $f(0) = 4$ and $g(5) = 17$, compute $f(2006)$.

Comprehension

Let $f : \mathbb{R} \rightarrow \mathbb{R}$ is a function satisfying $f(2 - x) = f(2 + x)$ and $f(20 - x) = f(x)$, $\forall x \in \mathbb{R}$.

On the basis of above information, answer the following questions :

12. If $f(0) = 5$, then minimum possible number of values of x satisfying $f(x) = 5$, for $x \in [0, 170]$ is -
 (A) 21 (B) 12 (C) 11 (D) 22
13. Graph of $y = f(x)$ is -
 (A) symmetrical about $x = 18$ (B) symmetrical about $x = 5$
 (C) symmetrical about $x = 8$ (D) symmetrical about $x = 20$
14. If $f(2) \neq f(6)$, then
 (A) fundamental period of $f(x)$ is 1 (B) fundamental period of $f(x)$ may be 1
 (C) period of $f(x)$ can't be 1 (D) fundamental period of $f(x)$ is 8
15. The function $f(x)$ has the property that for each real number x in its domain, $1/x$ is also in its domain and $f(x) + f(1/x) = x$. Find the largest set of real numbers that can be in the domain of $f(x)$?

EXERCISE (JM)

1. For real x , let $f(x) = x^3 + 5x + 1$, then :- [AIEEE - 2009]
- (1) f is one-one and onto \mathbb{R} (2) f is neither one-one nor onto \mathbb{R}
 (3) f is one-one but not onto \mathbb{R} (4) f is onto \mathbb{R} but not one-one

2. The domain of the function $f(x) = \frac{1}{\sqrt{|x| - x}}$ is :- [AIEEE - 2011]
- (1) $(-\infty, 0)$ (2) $(-\infty, \infty) - \{0\}$ (3) $(-\infty, \infty)$ (4) $(0, \infty)$

3. Let f be a function defined by $f(x) = (x - 1)^2 + 1$, ($x \geq 1$) [AIEEE - 2009, 2011]

Statement - 1 : The set $\{x : f(x) = f^{-1}(x)\} = \{1, 2\}$

Statement - 2 : f is bijection and $f^{-1}(x) = 1 + \sqrt{x - 1}$, $x \geq 1$.

- (1) Statement-1 is true, Statement-2 is false.
 (2) Statement-1 is false, Statement-2 is true.
 (3) Statement-1 is true, Statement-2 is true ; Statement-2 is a correct explanation for Statement-1.
 (4) Statement-1 is true, Statement-2 is true ; Statement-2 is not a correct explanation for statement-1.
4. If $a \in \mathbb{R}$ and the equation $-3(x - [x])^2 + 2(x - [x]) + a^2 = 0$ (where $[x]$ denotes the greatest integer $\leq x$) has no integral solution, then all possible values of a lie in the interval :

[JEE(Main)-2014]

- (1) $(-1, 0) \cup (0, 1)$ (2) $(1, 2)$ (3) $(-2, -1)$ (4) $(-\infty, -2) \cup (2, \infty)$

5. If $f(x) + 2f\left(\frac{1}{x}\right) = 3x$, $x \neq 0$, and [JEE(Main)-2016]

$S = \{x \in \mathbb{R} : f(x) = f(-x)\}$; then S :

- (1) contains more than two elements. (2) is an empty set.
 (3) contains exactly one element (4) contains exactly two elements

6. The function $f : \mathbb{R} \rightarrow \left[-\frac{1}{2}, \frac{1}{2}\right]$ defined as $f(x) = \frac{x}{1+x^2}$, is : [JEE(Main)-2017]

- (1) neither injective nor surjective. (2) invertible.
 (3) injective but not surjective. (4) surjective but not injective

7. Let $S = \{x \in \mathbb{R} : x \geq 0 \text{ and } 2|\sqrt{x} - 3| + \sqrt{x}(\sqrt{x} - 6) + 6 = 0\}$. Then S : [JEE(Main)-2018]

- (1) contains exactly one element. (2) contains exactly two elements.
 (3) contains exactly four elements. (4) is an empty set.

EXERCISE (JA)

1. If functions $f(x)$ and $g(x)$ are defined on $\mathbb{R} \rightarrow \mathbb{R}$ such that

$$f(x) = \begin{cases} 0, & x \in \text{rational} \\ x, & x \in \text{irrational} \end{cases}, \quad g(x) = \begin{cases} 0, & x \in \text{irrational} \\ x, & x \in \text{rational} \end{cases}, \text{ then } (f-g)(x) \text{ is -}$$

- (A) one-one and onto (B) neither one-one nor onto
 (C) one-one but not onto (D) onto but not one-one [JEE 2005 (Scr.)]
2. Let $f(x) = x^2$ and $g(x) = \sin x$ for all $x \in \mathbb{R}$. Then the set of all x satisfying $(f \circ g \circ g \circ f)(x) = (g \circ g \circ f)(x)$, where $(f \circ g)(x) = f(g(x))$, is- [JEE 2011, 3, (-1)]

(A) $\pm\sqrt{n\pi}, n \in \{0, 1, 2, \dots\}$ (B) $\pm\sqrt{n\pi}, n \in \{1, 2, \dots\}$
 (C) $\frac{\pi}{2} + 2n\pi, n \in \{\dots, -2, -1, 0, 1, 2, \dots\}$ (D) $2n\pi, n \in \{\dots, -2, -1, 0, 1, 2, \dots\}$

3. The function $f : [0, 3] \rightarrow [1, 29]$, defined by $f(x) = 2x^3 - 15x^2 + 36x + 1$, is : [JEE 2012, 3, (-1)]
 (A) one-one and onto (B) onto but not one-one
 (C) one-one but not onto (D) neither one-one nor onto

4. Let $f : (-1, 1) \rightarrow \mathbb{R}$ be such that $f(\cos 4\theta) = \frac{2}{2 - \sec^2 \theta}$ for $\theta \in \left(0, \frac{\pi}{4}\right) \cup \left(\frac{\pi}{4}, \frac{\pi}{2}\right)$. Then the value(s) of

$f\left(\frac{1}{3}\right)$ is (are) - [JEE 2012, 4]

(A) $1 - \sqrt{\frac{3}{2}}$ (B) $1 + \sqrt{\frac{3}{2}}$ (C) $1 - \sqrt{\frac{2}{3}}$ (D) $1 + \sqrt{\frac{2}{3}}$

5. Let $f : \left(-\frac{\pi}{2}, \frac{\pi}{2}\right) \rightarrow \mathbb{R}$ be given by $f(x) = (\log(\sec x + \tan x))^3$. Then :-

(A) $f(x)$ is an odd function (B) $f(x)$ is a one-one function
 (C) $f(x)$ is an onto function (D) $f(x)$ is an even function

[JEE(Advanced)-2014, 3]

INVERSE TRIGONOMETRIC FUNCTION

1. INTRODUCTION :

The inverse trigonometric functions, denoted by $\sin^{-1}x$ or $(\text{arc sin}x)$, $\cos^{-1}x$ etc., denote the angles whose sine, cosine etc, is equal to x . The angles are usually the numerically smallest angles, except in the case of $\cot^{-1}x$ and if positive & negative angles have same numerical value, the positive angle has been chosen.

It is worthwhile noting that the functions $\sin x$, $\cos x$ etc are in general not invertible. Their inverse is defined by choosing an appropriate domain & co-domain so that they become invertible. For this reason the chosen value is usually the simplest and easy to remember.

2. DOMAIN & RANGE OF INVERSE TRIGONOMETRIC FUNCTIONS :

S.No	$f(x)$	Domain	Range
(1)	$\sin^{-1}x$	$ x \leq 1$	$\left[-\frac{\pi}{2}, \frac{\pi}{2}\right]$
(2)	$\cos^{-1}x$	$ x \leq 1$	$[0, \pi]$
(3)	$\tan^{-1}x$	$x \in \mathbb{R}$	$\left(-\frac{\pi}{2}, \frac{\pi}{2}\right)$
(4)	$\sec^{-1}x$	$ x \geq 1$	$[0, \pi] - \left\{\frac{\pi}{2}\right\}$ or $\left[0, \frac{\pi}{2}\right) \cup \left(\frac{\pi}{2}, \pi\right]$
(5)	$\text{cosec}^{-1}x$	$ x \geq 1$	$\left[-\frac{\pi}{2}, \frac{\pi}{2}\right] - \{0\}$
(6)	$\cot^{-1}x$	$x \in \mathbb{R}$	$(0, \pi)$

3. GRAPH OF INVERSE TRIGONOMETRIC FUNCTIONS :

(a) $f: \left[-\frac{\pi}{2}, \frac{\pi}{2}\right] \rightarrow [-1, 1]$

$f(x) = \sin x$

$f^{-1}: [-1, 1] \rightarrow [-\pi/2, \pi/2]$

$f^{-1}(x) = \sin^{-1}(x)$

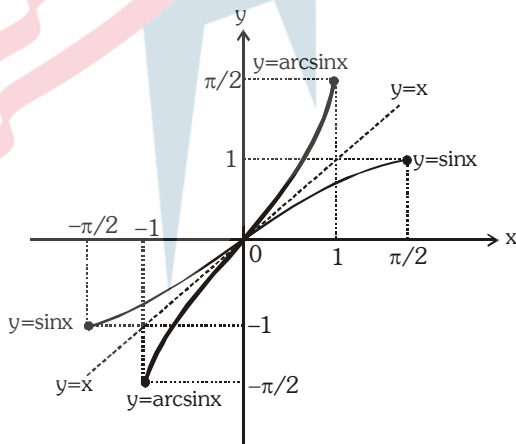

(Taking image of $\sin x$ about $y = x$ to get $\sin^{-1}x$)

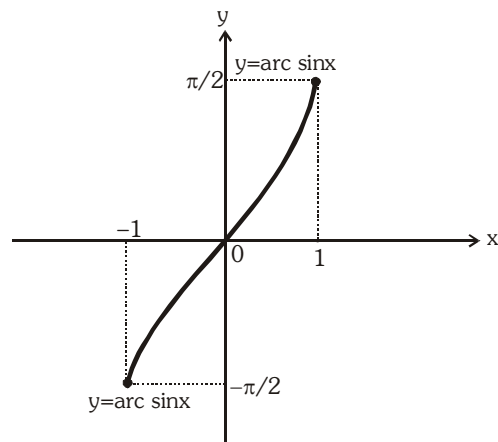

($y = \sin^{-1}x$)

Inverse Trigonometric Function

(b) $f: [0, \pi] \rightarrow [-1, 1]$
 $f(x) = \cos x$

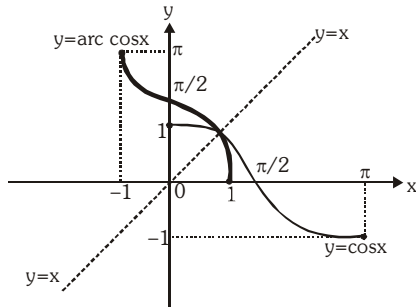

(Taking image of $\cos x$ about $y = x$)

$f^{-1}: [-1, 1] \rightarrow [0, \pi]$
 $f^{-1}(x) = \cos^{-1} x$

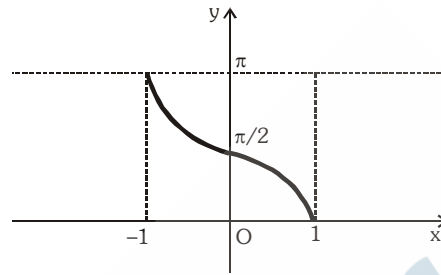

($y = \cos^{-1} x$)

(c) $f: (-\pi/2, \pi/2) \rightarrow \mathbb{R}$
 $f(x) = \tan x$

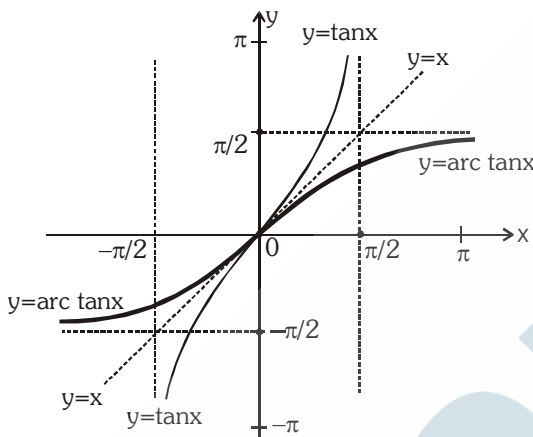

(Taking image of $\tan x$ about $y = x$)

$f^{-1}: \mathbb{R} \rightarrow (-\pi/2, \pi/2)$
 $f^{-1}(x) = \tan^{-1} x$

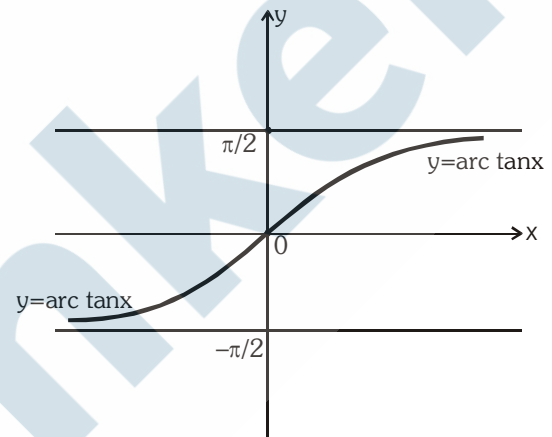

($y = \tan^{-1} x$)

(d) $f: (0, \pi) \rightarrow \mathbb{R}$
 $f(x) = \cot x$

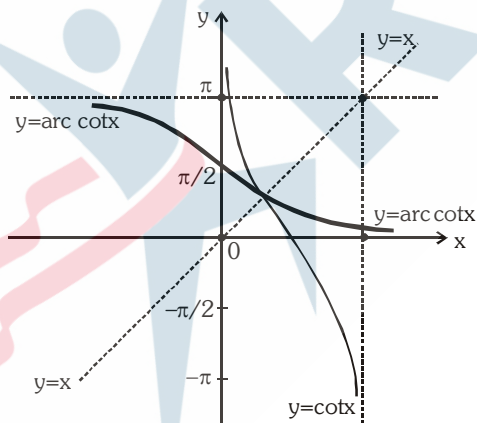

(Taking image of $\cot x$ about $y = x$)

$f^{-1}: \mathbb{R} \rightarrow (0, \pi)$
 $f^{-1}(x) = \cot^{-1} x$

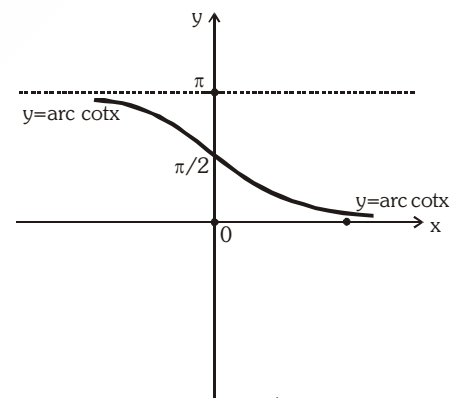

($y = \cot^{-1} x$)

(e) $f: [0, \pi/2) \cup (\pi/2, \pi] \rightarrow (-\infty, -1] \cup [1, \infty)$
 $f(x) = \sec x$
 $f^{-1}: (-\infty, -1] \cup [1, \infty) \rightarrow [0, \pi/2) \cup (\pi/2, \pi]$
 $f^{-1}(x) = \sec^{-1} x$

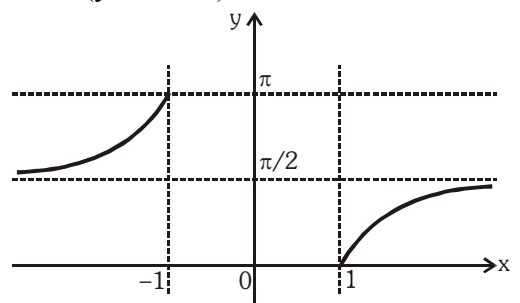

(f) $f: [-\pi/2, 0) \cup (0, \pi/2] \rightarrow (-\infty, -1] \cup [1, \infty)$

$f(x) = \operatorname{cosec} x$

$f^{-1}: (-\infty, -1] \cup [1, \infty) \rightarrow [-\pi/2, 0) \cup (0, \pi/2]$

$f^{-1}(x) = \operatorname{cosec}^{-1} x$

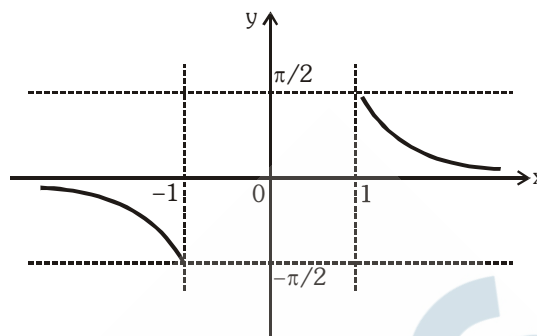

From the above discussions following IMPORTANT points can be concluded :

- (i) All the inverse trigonometric functions represent an angle.
- (ii) If $x > 0$, then all six inverse trigonometric functions viz $\sin^{-1} x$, $\cos^{-1} x$, $\tan^{-1} x$, $\sec^{-1} x$, $\operatorname{cosec}^{-1} x$, $\cot^{-1} x$ represent an acute angle.
- (iii) If $x < 0$, then $\sin^{-1} x$, $\tan^{-1} x$ & $\operatorname{cosec}^{-1} x$ represent an angle from $-\pi/2$ to 0 (IVth quadrant)
- (iv) If $x < 0$, then $\cos^{-1} x$, $\cot^{-1} x$ & $\sec^{-1} x$ represent an obtuse angle. (IInd quadrant)
- (v) IIIrd quadrant is never used in range of inverse trigonometric function.

Illustration 1 : The value of $\tan^{-1}(1) + \cos^{-1}\left(-\frac{1}{2}\right) + \sin^{-1}\left(-\frac{1}{2}\right)$ is equal to

- (A) $\frac{\pi}{4}$ (B) $\frac{5\pi}{12}$ (C) $\frac{3\pi}{4}$ (D) $\frac{13\pi}{12}$

Solution : $\tan^{-1}(1) + \cos^{-1}\left(-\frac{1}{2}\right) + \sin^{-1}\left(-\frac{1}{2}\right) = \frac{\pi}{4} + \frac{2\pi}{3} - \frac{\pi}{6} = \frac{\pi}{4} + \frac{\pi}{2} = \frac{3\pi}{4}$ **Ans.(C)**

Illustration 2 : If $\sum_{i=1}^{2n} \cos^{-1} x_i = 0$ then find the value of $\sum_{i=1}^{2n} x_i$

Solution : We know, $0 \leq \cos^{-1} x \leq \pi$
Hence, each value $\cos^{-1} x_1, \cos^{-1} x_2, \cos^{-1} x_3, \dots, \cos^{-1} x_{2n}$ are non-negative their sum is zero only when each value is zero.

i.e., $\cos^{-1} x_i = 0$ for all i

$\Rightarrow x_i = 1$ for all i

$\therefore \sum_{i=1}^{2n} x_i = x_1 + x_2 + x_3 + \dots + x_{2n} = \underbrace{\{1+1+1+\dots+1\}}_{2n \text{ times}} = 2n$ {using (i)}

$\Rightarrow \sum_{i=1}^{2n} x_i = 2n$ **Ans.**

Do yourself - 1 :

- (i) If α, β are roots of the equation $6x^2 + 11x + 3 = 0$, then
 (A) both $\cos^{-1}\alpha$ and $\cos^{-1}\beta$ are real (B) both $\operatorname{cosec}^{-1}\alpha$ and $\operatorname{cosec}^{-1}\beta$ are real
 (C) both $\cot^{-1}\alpha$ and $\cot^{-1}\beta$ are real (D) none of these
- (ii) If $\sin^{-1}x + \sin^{-1}y = \pi$ and $x = ky$, then find the value of $39^{2k} + 5^k$.

3. PROPERTIES OF INVERSE CIRCULAR FUNCTIONS :

P-1 (i) $y = \sin(\sin^{-1}x) = x$
 $x \in [-1,1], y \in [-1,1]$

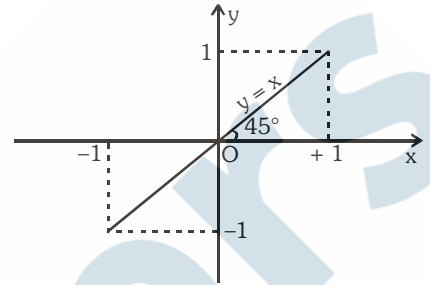

(ii) $y = \cos(\cos^{-1}x) = x$
 $x \in [-1,1], y \in [-1,1]$

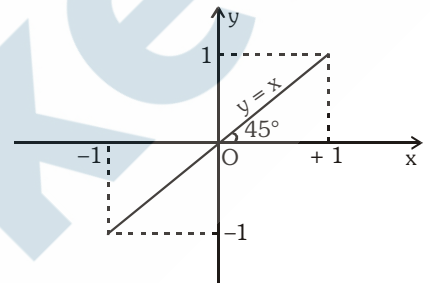

(iii) $y = \tan(\tan^{-1}x) = x$
 $x \in \mathbb{R}, y \in \mathbb{R}$

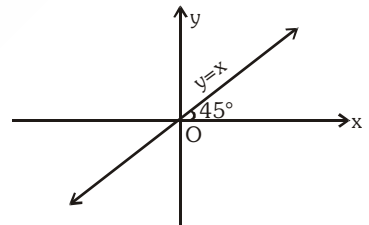

(iv) $y = \cot(\cot^{-1}x) = x$,
 $x \in \mathbb{R}; y \in \mathbb{R}$

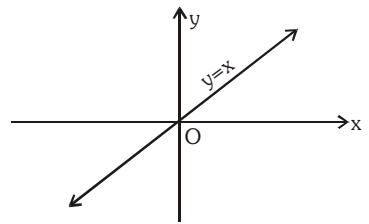

(v) $y = \operatorname{cosec}(\operatorname{cosec}^{-1}x) = x$,
 $|x| \geq 1, |y| \geq 1$

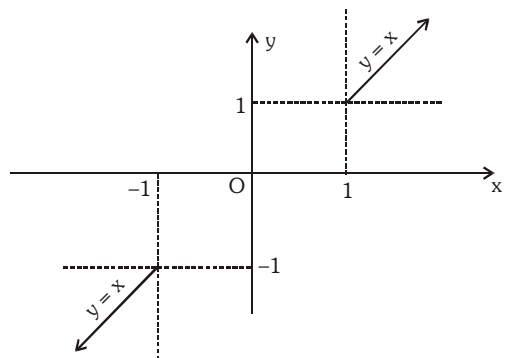

(vi) $y = \sec(\sec^{-1} x) = x$

$|x| \geq 1 ; |y| \geq 1$

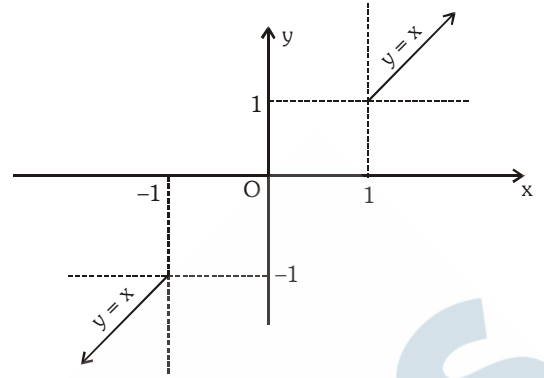

Note : All the above functions are aperiodic.

Illustration 3 : Evaluate the following :

- (i) $\sin(\cos^{-1} 3/5)$ (ii) $\cos(\tan^{-1} 3/4)$ (iii) $\sin\left(\frac{\pi}{2} - \sin^{-1}\left(-\frac{1}{2}\right)\right)$
- (iv) $\tan\left\{2 \tan^{-1} \frac{1}{5} - \frac{\pi}{4}\right\}$

Solution :

(i) Let $\cos^{-1} 3/5 = \theta$. Then,
 $\cos\theta = 3/5 \Rightarrow \sin\theta = 4/5$
 $\therefore \sin(\cos^{-1} 3/5) = \sin\theta = 4/5$

(ii) Let $\tan^{-1} 3/4 = \theta$. Then,
 $\tan\theta = 3/4$
 $\Rightarrow \cos\theta = \frac{4}{5}$ $\left\{ \because \text{as } \cos^2 \theta = \frac{1}{1 + \tan^2 \theta} \right\}$
 $\therefore \cos(\tan^{-1} 3/4) = \cos\theta = 4/5$

(iii) $\sin\left(\frac{\pi}{2} - \sin^{-1}\left(-\frac{1}{2}\right)\right) = \sin\left(\frac{\pi}{2} - \left(-\frac{\pi}{6}\right)\right) = \sin\frac{2\pi}{3} = \frac{\sqrt{3}}{2}$

(iv) Let $\tan^{-1}\left(\frac{1}{5}\right) = \theta \Rightarrow \tan\theta = \frac{1}{5}$

$$\tan\left(2\theta - \frac{\pi}{4}\right) = \frac{\tan(2\theta) - 1}{1 + \tan 2\theta} \text{ and } \tan 2\theta = \frac{2 \times \frac{1}{5}}{1 - \frac{1}{25}} = \frac{5}{12} \quad (\because \tan\theta = \frac{1}{5})$$

$$\Rightarrow \tan\left(2\theta - \frac{\pi}{4}\right) = \frac{\frac{5}{12} - 1}{1 + \frac{5}{12}} = -\frac{7}{17}$$

Ans.

Illustration 4 : Prove that $\sec^2(\tan^{-1}2) + \operatorname{cosec}^2(\cot^{-1}3) = 15$

Solution :

We have,

$$\sec^2(\tan^{-1}2) + \operatorname{cosec}^2(\cot^{-1}3)$$

$$= \left\{ \sec(\tan^{-1}2) \right\}^2 + \left\{ \operatorname{cosec}(\cot^{-1}3) \right\}^2 = \left\{ \sec\left(\tan^{-1}\frac{2}{1}\right) \right\}^2 + \left\{ \operatorname{cosec}\left(\cot^{-1}\frac{3}{1}\right) \right\}^2$$

$$= \left\{ \sec(\sec^{-1}\sqrt{5}) \right\}^2 + \left\{ \operatorname{cosec}(\operatorname{cosec}^{-1}\sqrt{10}) \right\}^2 = (\sqrt{5})^2 + (\sqrt{10})^2 = 15$$

Do yourself - 2 :

Evaluate the following :

(i) $\tan\left(\cos^{-1}\left(\frac{8}{17}\right)\right)$ (ii) $\sin\left(\frac{1}{2}\cos^{-1}\left(\frac{4}{5}\right)\right)$ (iii) $\sin\left(\frac{\pi}{3} - \sin^{-1}\left(\frac{-1}{2}\right)\right)$ (iv) $\sin\left(\cos^{-1}\frac{3}{5}\right)$

P-2 (i) $y = \sin^{-1}(\sin x)$, $x \in \mathbb{R}$, $y \in \left[-\frac{\pi}{2}, \frac{\pi}{2}\right]$ periodic with period 2π and it is an odd function.

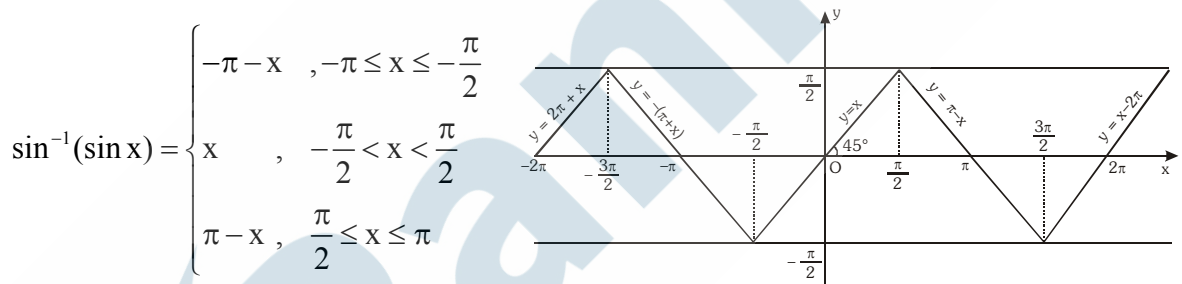

(ii) $y = \cos^{-1}(\cos x)$, $x \in \mathbb{R}$, $y \in [0, \pi]$, periodic with period 2π and it is an even function.

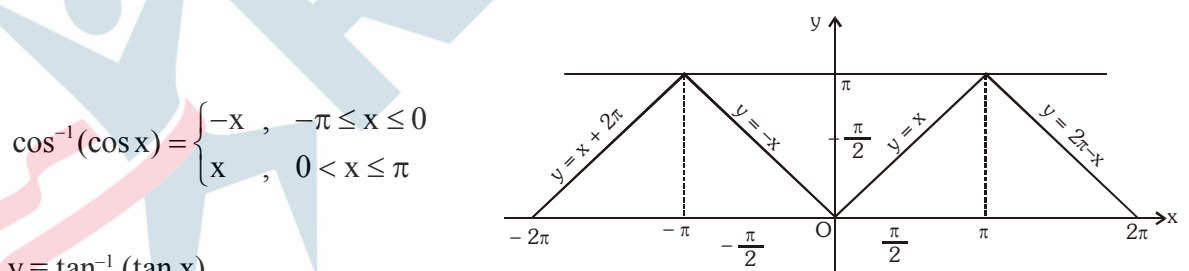

(iii) $y = \tan^{-1}(\tan x)$

$x \in \mathbb{R} - \left\{ (2n-1)\frac{\pi}{2}, n \in \mathbb{I} \right\}$; $y \in \left(-\frac{\pi}{2}, \frac{\pi}{2}\right)$, periodic with period π and it is an odd function.

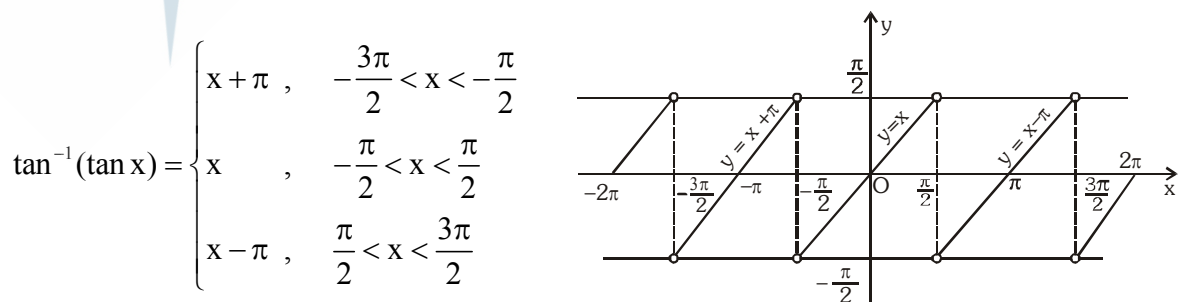

- (iv) $y = \cot^{-1}(\cot x)$, $x \in \mathbb{R} - \{n\pi, n \in \mathbb{I}\}$, $y \in (0, \pi)$, periodic with period π and neither even nor odd function.

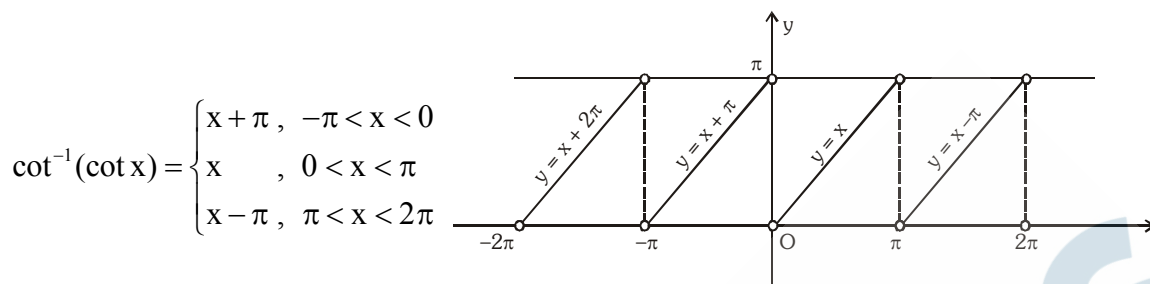

- (v) $y = \operatorname{cosec}^{-1}(\operatorname{cosec} x)$, $x \in \mathbb{R} - \{n\pi, n \in \mathbb{I}\}$, $y \in \left[-\frac{\pi}{2}, 0\right) \cup \left(0, \frac{\pi}{2}\right]$, is periodic with period 2π and it is an odd function.

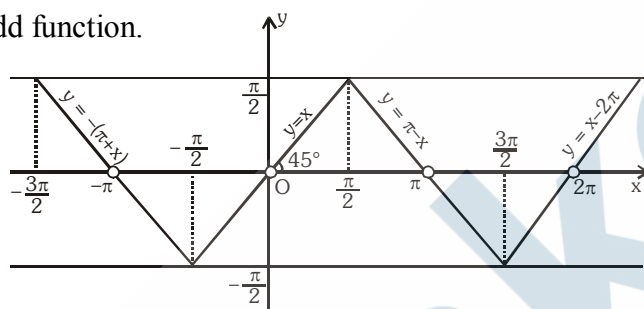

- (vi) $y = \sec^{-1}(\sec x)$, y is periodic with period 2π and it is an even function.

$$x \in \mathbb{R} - \left\{ (2n-1)\frac{\pi}{2}, n \in \mathbb{I} \right\}, y \in \left[0, \frac{\pi}{2}\right) \cup \left(\frac{\pi}{2}, \pi\right]$$

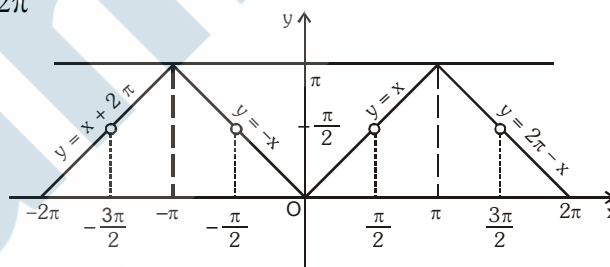

Illustration 5: The value of $\sin^{-1}(-\sqrt{3}/2) + \cos^{-1}(\cos(7\pi/6))$ is -

- (A) $5\pi/6$ (B) $\pi/2$ (C) $3\pi/2$ (D) none of these

Solution: $\sin^{-1}(-\sqrt{3}/2) = -\sin^{-1}(\sqrt{3}/2) = -\pi/3$

and $\cos^{-1}(\cos(7\pi/6)) = \cos^{-1}(\cos(2\pi - 5\pi/6)) = \cos^{-1}(\cos(5\pi/6)) = 5\pi/6$

Hence $\sin^{-1}(-\sqrt{3}/2) + \cos^{-1}(\cos 7\pi/6) = -\frac{\pi}{3} + \frac{5\pi}{6} = \frac{\pi}{2}$

Ans.(B)

Illustration 6: Evaluate the following :

- (i) $\sin^{-1}(\sin 10)$ (ii) $\tan^{-1}(\tan(-6))$ (iii) $\cot^{-1}(\cot 4)$

Solution : (i) We know that $\sin^{-1}(\sin\theta) = \theta$, if $-\pi/2 \leq \theta \leq \pi/2$

Here, $\theta = 10$ radians which does not lie between $-\pi/2$ and $\pi/2$

But, $3\pi - \theta$ i.e., $3\pi - 10$ lie between $-\frac{\pi}{2}$ and $\frac{\pi}{2}$

Also, $\sin(3\pi - 10) = \sin 10$

$\therefore \sin^{-1}(\sin 10) = \sin^{-1}(\sin(3\pi - 10)) = (3\pi - 10)$

(ii) We know that,

$\tan^{-1}(\tan\theta) = \theta$, if $-\pi/2 < \theta < \pi/2$. Here, $\theta = -6$, radians which does not lie between $-\pi/2$ and $\pi/2$. We find that $2\pi - 6$ lies between $-\pi/2$ and $\pi/2$ such that;

$\tan(2\pi - 6) = -\tan 6 = \tan(-6)$

$\therefore \tan^{-1}(\tan(-6)) = \tan^{-1}(\tan(2\pi - 6)) = (2\pi - 6)$

(iii) $\cot^{-1}(\cot 4) = \cot^{-1}(\cot(\pi + (4 - \pi))) = \cot^{-1}(\cot(4 - \pi)) = (4 - \pi)$

Ans.

Illustration 7 : Find the number of solutions of (x, y) which satisfy $|y| = \cos x$ and $y = \sin^{-1}(\sin x)$, where $|x| \leq 3\pi$.

Solution : Graphs of $y = \sin^{-1}(\sin x)$ and $|y| = \cos x$ meet exactly six times in $[-3\pi, 3\pi]$.

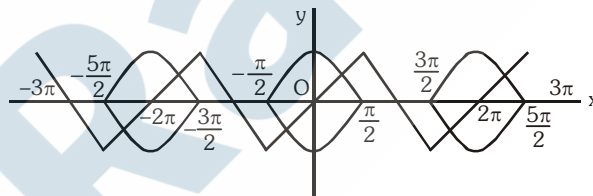

Do yourself - 3 :

Evaluate the following :

(i) $\cos^{-1}\left(\cos\frac{13\pi}{6}\right)$ (ii) $\tan^{-1}\left(\tan\left(\frac{7\pi}{6}\right)\right)$ (iii) $\sin^{-1}\left(\sin\left(\frac{5\pi}{6}\right)\right)$

P-3 (i) $\sin^{-1} x + \cos^{-1} x = \frac{\pi}{2}$ $|x| \leq 1$

(ii) $\tan^{-1} x + \cot^{-1} x = \frac{\pi}{2}$ $x \in \mathbb{R}$

(iii) $\operatorname{cosec}^{-1} x + \sec^{-1} x = \frac{\pi}{2}$ $|x| \geq 1$

- P-4** (i) $\sin^{-1}(-x) = -\sin^{-1} x$, $|x| \leq 1$
(ii) $\operatorname{cosec}^{-1}(-x) = -\operatorname{cosec}^{-1} x$, $|x| \geq 1$
(iii) $\tan^{-1}(-x) = -\tan^{-1} x$, $x \in \mathbf{R}$
(iv) $\cot^{-1}(-x) = \pi - \cot^{-1} x$, $x \in \mathbf{R}$
(v) $\cos^{-1}(-x) = \pi - \cos^{-1} x$, $|x| \leq 1$
(vi) $\sec^{-1}(-x) = \pi - \sec^{-1} x$, $|x| \geq 1$

- P-5** (i) $\operatorname{cosec}^{-1} x = \sin^{-1} \frac{1}{x}$; $|x| \geq 1$
(ii) $\sec^{-1} x = \cos^{-1} \frac{1}{x}$; $|x| \geq 1$
(iii) $\cot^{-1} x = \begin{cases} \tan^{-1} \frac{1}{x} & ; x > 0 \\ \pi + \tan^{-1} \frac{1}{x} & ; x < 0 \end{cases}$

Illustration 8 : Find value of x if $\cos^{-1}(-x) + \tan^{-1}(-x) - 2\sin^{-1}(x) + \sec^{-1}\left(-\frac{1}{x}\right) = \frac{\pi}{4}$ for $|x| \leq 1$.

Solution :

$$\pi - \cos^{-1}(x) - \tan^{-1}(x) - 2\sin^{-1}(x) + \cos^{-1}(-x) = \frac{\pi}{4}$$

$$\pi - \cos^{-1}(x) - \tan^{-1}(x) - 2\sin^{-1}(x) + \pi - \cos^{-1}(x) = \frac{\pi}{4}$$

$$2\pi - 2(\sin^{-1}x + \cos^{-1}x) - \frac{\pi}{4} = \tan^{-1}x$$

$$2\pi - \pi - \frac{\pi}{4} = \tan^{-1}x \Rightarrow \tan^{-1}x = \frac{3\pi}{4} \text{ Hence no solution}$$

Ans.

Do yourself - 4 :

(i) Prove the following :

(a) $\cos^{-1}\left(\frac{5}{13}\right) = \tan^{-1}\left(\frac{12}{5}\right)$

(b) $\sin^{-1}\left(-\frac{4}{5}\right) = \tan^{-1}\left(-\frac{4}{3}\right) = \cos^{-1}\left(-\frac{3}{5}\right) - \pi$

(ii) Find the value of $\sin(\tan^{-1}a + \tan^{-1}\frac{1}{a})$; $a \neq 0$

P-6 (i) (a) $\tan^{-1} x + \tan^{-1} y = \begin{cases} \tan^{-1} \frac{x+y}{1-xy} & \text{where } x > 0, y > 0 \text{ \& } xy < 1 \\ \pi + \tan^{-1} \frac{x+y}{1-xy} & \text{where } x > 0, y > 0 \text{ \& } xy > 1 \\ \frac{\pi}{2}, & \text{where } x > 0, y > 0 \text{ \& } xy = 1 \end{cases}$

(b) $\tan^{-1} x - \tan^{-1} y = \tan^{-1} \frac{x-y}{1+xy}$ where $x > 0, y > 0$

(c) $\tan^{-1} x + \tan^{-1} y + \tan^{-1} z = \tan^{-1} \left[\frac{x+y+z-xyz}{1-xy-yz-zx} \right]$ if $x > 0, y > 0, z > 0$ & $xy + yz + zx < 1$

(ii) (a) $\sin^{-1} x + \sin^{-1} y = \begin{cases} \sin^{-1}[x\sqrt{1-y^2} + y\sqrt{1-x^2}] & \text{where } x > 0, y > 0 \text{ \& } (x^2 + y^2) \leq 1 \\ \pi - \sin^{-1}[x\sqrt{1-y^2} + y\sqrt{1-x^2}] & \text{where } x > 0, y > 0 \text{ \& } x^2 + y^2 > 1 \end{cases}$

(b) $\sin^{-1} x - \sin^{-1} y = \sin^{-1} [x\sqrt{1-y^2} - y\sqrt{1-x^2}]$ where $x > 0, y > 0$

(iii) (a) $\cos^{-1} x + \cos^{-1} y = \cos^{-1} [xy - \sqrt{1-x^2}\sqrt{1-y^2}]$ where $x > 0, y > 0$

(b) $\cos^{-1} x - \cos^{-1} y = \begin{cases} \cos^{-1}(xy + \sqrt{1-x^2}\sqrt{1-y^2}) & ; \quad x < y, \quad x, y > 0 \\ -\cos^{-1}(xy + \sqrt{1-x^2}\sqrt{1-y^2}) & ; \quad x > y, \quad x, y > 0 \end{cases}$

Note : In the above results x & y are taken positive. In case if these are given as negative, we first apply **P-4** and then use above results.

Illustration 9 : Prove that

(i) $\tan^{-1} \frac{1}{7} + \tan^{-1} \frac{1}{13} = \tan^{-1} \frac{2}{9}$ (ii) $\tan^{-1} \frac{1}{5} + \tan^{-1} \frac{1}{7} + \tan^{-1} \frac{1}{3} + \tan^{-1} \frac{1}{8} = \frac{\pi}{4}$

Solution :

(i) L.H.S. = $\tan^{-1} \frac{1}{7} + \tan^{-1} \frac{1}{13}$

$$= \tan^{-1} \left\{ \frac{\frac{1}{7} + \frac{1}{13}}{1 - \frac{1}{7} \times \frac{1}{13}} \right\} \quad \left\{ \because \tan^{-1} x + \tan^{-1} y = \tan^{-1} \left(\frac{x+y}{1-xy} \right); \text{ if } xy < 1 \right\}$$

$$= \tan^{-1} \left(\frac{20}{90} \right) = \tan^{-1} \left(\frac{2}{9} \right) = \text{R.H.S.}$$

(ii) $\left(\tan^{-1} \frac{1}{5} + \tan^{-1} \frac{1}{7} \right) + \left(\tan^{-1} \frac{1}{3} + \tan^{-1} \frac{1}{8} \right)$

$$= \tan^{-1} \left(\frac{\frac{1}{5} + \frac{1}{7}}{1 - \frac{1}{5} \times \frac{1}{7}} \right) + \tan^{-1} \left(\frac{\frac{1}{3} + \frac{1}{8}}{1 - \frac{1}{3} \times \frac{1}{8}} \right) = \tan^{-1} \left(\frac{6}{17} \right) + \tan^{-1} \left(\frac{11}{23} \right)$$

$$= \tan^{-1} \left(\frac{\frac{6}{17} + \frac{11}{23}}{1 - \frac{6}{17} \times \frac{11}{23}} \right) = \tan^{-1} \left(\frac{325}{325} \right) = \tan^{-1}(1) = \frac{\pi}{4}$$

Ans.

Illustration 10 : Prove that $\sin^{-1} \frac{12}{13} + \cot^{-1} \frac{4}{3} + \tan^{-1} \frac{63}{16} = \pi$

Solution : We have,

$$\begin{aligned} & \sin^{-1} \frac{12}{13} + \cos^{-1} \frac{4}{5} + \tan^{-1} \frac{63}{16} \\ &= \tan^{-1} \frac{12}{5} + \tan^{-1} \frac{3}{4} + \tan^{-1} \frac{63}{16} \quad \left[\because \sin^{-1} \frac{12}{13} = \tan^{-1} \frac{12}{5} \text{ and } \cos^{-1} \frac{4}{5} = \tan^{-1} \frac{3}{4} \right] \\ &= \pi + \tan^{-1} \left\{ \frac{\frac{12}{5} + \frac{3}{4}}{1 - \frac{12}{5} \times \frac{3}{4}} \right\} + \tan^{-1} \frac{63}{16} \quad \left[\because \tan^{-1} x + \tan^{-1} y = \pi + \tan^{-1} \left(\frac{x+y}{1-xy} \right), \text{ if } xy > 1 \right] \\ &= \pi + \tan^{-1} \left(\frac{63}{-16} \right) + \tan^{-1} \left(\frac{63}{16} \right) \\ &= \pi - \tan^{-1} \frac{63}{16} + \tan^{-1} \frac{63}{16} \quad \left[\because \tan^{-1}(-x) = -\tan^{-1} x \right] \\ &= \pi \end{aligned}$$

Illustration 11 : Prove that : $\cos^{-1} \frac{12}{13} + \sin^{-1} \frac{3}{5} = \sin^{-1} \frac{56}{65}$

Solution :

We have, L.H.S. = $\cos^{-1} \left(\frac{12}{13} \right) + \sin^{-1} \left(\frac{3}{5} \right) = \tan^{-1} \left(\frac{5}{12} \right) + \tan^{-1} \left(\frac{3}{4} \right)$

$$\left[\because \cos^{-1} \left(\frac{12}{13} \right) = \tan^{-1} \left(\frac{5}{12} \right) \text{ \& } \sin^{-1} \left(\frac{3}{5} \right) = \tan^{-1} \left(\frac{3}{4} \right) \right]$$

$$\text{L.H.S.} = \tan^{-1} \left(\frac{\frac{5}{12} + \frac{3}{4}}{1 - \frac{5}{12} \times \frac{3}{4}} \right) = \tan^{-1} \left(\frac{56}{33} \right)$$

$$\text{R.H.S.} = \sin^{-1} \left(\frac{56}{65} \right) = \tan^{-1} \left(\frac{56}{33} \right)$$

L.H.S. = R.H.S. Hence Proved

Do yourself - 5 :

Prove the following :

(i) $\sin^{-1}\left(\frac{3}{5}\right) + \sin^{-1}\left(\frac{8}{17}\right) = \cos^{-1}\left(\frac{36}{85}\right)$

(ii) $\tan^{-1}\left(\frac{3}{4}\right) + \tan^{-1}\left(\frac{3}{5}\right) - \tan^{-1}\left(\frac{8}{19}\right) = \frac{\pi}{4}$

(iii) $\tan^{-1}\left(\frac{2}{11}\right) + \tan^{-1}\left(\frac{7}{24}\right) = \tan^{-1}\left(\frac{1}{2}\right)$

4. SIMPLIFIED INVERSE TRIGONOMETRIC FUNCTIONS :

(a) $y = f(x) = \sin^{-1}\left(\frac{2x}{1+x^2}\right) = \begin{cases} 2 \tan^{-1} x & \text{if } |x| \leq 1 \\ \pi - 2 \tan^{-1} x & \text{if } x > 1 \\ -(\pi + 2 \tan^{-1} x) & \text{if } x < -1 \end{cases}$

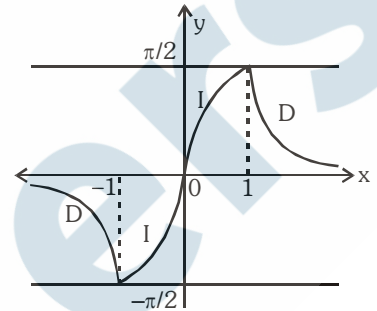

(b) $y = f(x) = \cos^{-1}\left(\frac{1-x^2}{1+x^2}\right) = \begin{cases} 2 \tan^{-1} x & \text{if } x \geq 0 \\ -2 \tan^{-1} x & \text{if } x < 0 \end{cases}$

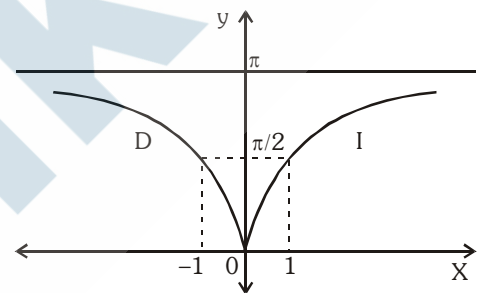

(c) $y = f(x) = \tan^{-1}\left(\frac{2x}{1-x^2}\right) = \begin{cases} 2 \tan^{-1} x & \text{if } |x| < 1 \\ \pi + 2 \tan^{-1} x & \text{if } x < -1 \\ -(\pi - 2 \tan^{-1} x) & \text{if } x > 1 \end{cases}$

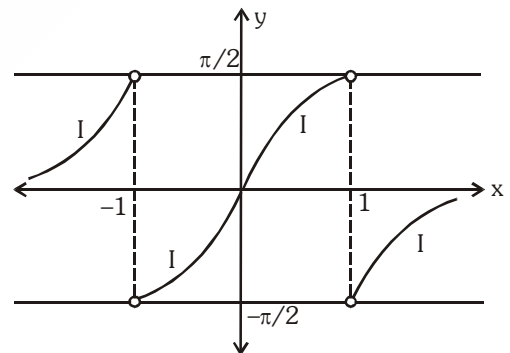

(d) $y = f(x) = \sin^{-1}(3x - 4x^3)$

$$= \begin{cases} -(\pi + 3 \sin^{-1} x) & \text{if } -1 \leq x \leq -\frac{1}{2} \\ 3 \sin^{-1} x & \text{if } -\frac{1}{2} \leq x \leq \frac{1}{2} \\ \pi - 3 \sin^{-1} x & \text{if } \frac{1}{2} \leq x \leq 1 \end{cases}$$

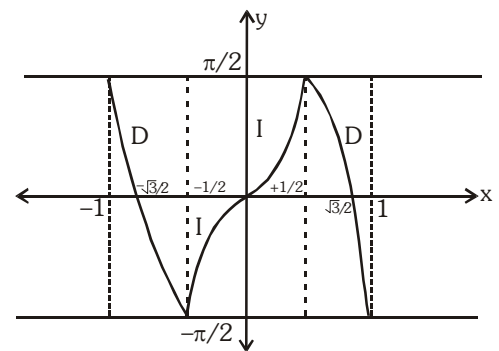

(e) $y = f(x) = \cos^{-1}(4x^3 - 3x)$

$$= \begin{cases} 3 \cos^{-1} x - 2\pi & \text{if } -1 \leq x \leq -\frac{1}{2} \\ 2\pi - 3 \cos^{-1} x & \text{if } -\frac{1}{2} \leq x \leq \frac{1}{2} \\ 3 \cos^{-1} x & \text{if } \frac{1}{2} \leq x \leq 1 \end{cases}$$

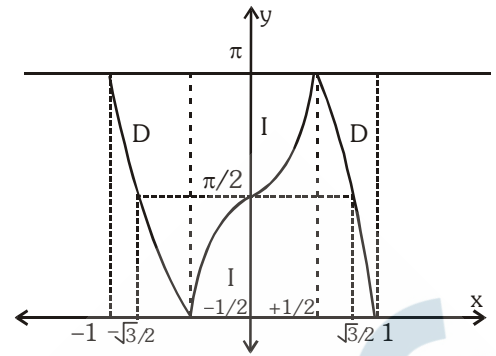

(f) $\sin^{-1}(2x\sqrt{1-x^2}) = \begin{cases} -(\pi + 2 \sin^{-1} x) & -1 \leq x \leq -\frac{1}{\sqrt{2}} \\ 2 \sin^{-1} x & -\frac{1}{\sqrt{2}} \leq x \leq \frac{1}{\sqrt{2}} \\ \pi - 2 \sin^{-1} x & \frac{1}{\sqrt{2}} \leq x \leq 1 \end{cases}$

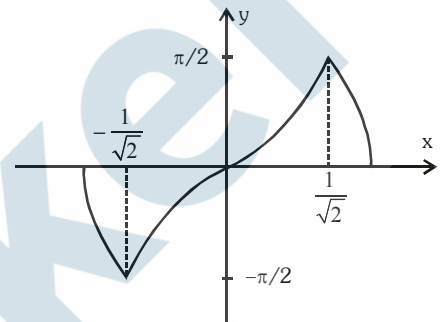

(g) $\cos^{-1}(2x^2 - 1) = \begin{cases} 2 \cos^{-1} x & 0 \leq x \leq 1 \\ 2\pi - 2 \cos^{-1} x & -1 \leq x \leq 0 \end{cases}$

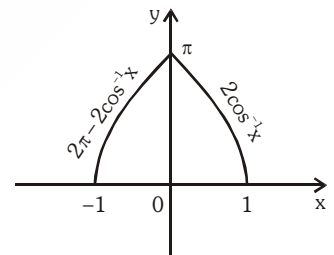

Illustration 12 : Prove that : $2 \tan^{-1} \frac{1}{2} + \tan^{-1} \frac{1}{7} = \tan^{-1} \frac{31}{17}$

Solution : We have, $2 \tan^{-1} \frac{1}{2} + \tan^{-1} \frac{1}{7}$

$$= \tan^{-1} \left\{ \frac{2 \times \frac{1}{2}}{1 - \left(\frac{1}{2}\right)^2} \right\} + \tan^{-1} \frac{1}{7}$$

$$\left[\because 2 \tan^{-1} x = \tan^{-1} \left(\frac{2x}{1-x^2} \right), \text{ if } -1 < x < 1 \right]$$

$$= \tan^{-1} \frac{4}{3} + \tan^{-1} \frac{1}{7} = \tan^{-1} \left\{ \frac{\frac{4}{3} + \frac{1}{7}}{1 - \frac{4}{3} \times \frac{1}{7}} \right\} = \tan^{-1} \frac{31}{17}$$

Illustration 13 : Prove that $\tan^{-1} \sqrt{x} = \frac{1}{2} \cos^{-1} \left(\frac{1-x}{1+x} \right), x \in [0, 1]$

Solution : We have, $\frac{1}{2} \cos^{-1} \left(\frac{1-x}{1+x} \right) = \frac{1}{2} \cos^{-1} \left\{ \frac{1 - (\sqrt{x})^2}{1 + (\sqrt{x})^2} \right\} = \frac{1}{2} \times 2 \tan^{-1} \sqrt{x} = \tan^{-1} \sqrt{x}$.

Alter : Putting $\sqrt{x} = \tan \theta$, we have $\Rightarrow \theta \in \left[0, \frac{\pi}{4} \right]$

$$\begin{aligned} \text{RHS} &= \frac{1}{2} \cos^{-1} \left(\frac{1-x}{1+x} \right) = \frac{1}{2} \cos^{-1} \left(\frac{1 - \tan^2 \theta}{1 + \tan^2 \theta} \right) = \frac{1}{2} \cos^{-1} (\cos 2\theta) = \theta \quad \because \left(2\theta \in \left[0, \frac{\pi}{2} \right] \right) \\ &= \tan^{-1} \sqrt{x} = \text{LHS} \end{aligned}$$

Illustration 14 : Prove that : (i) $4 \tan^{-1} \frac{1}{5} - \tan^{-1} \frac{1}{70} + \tan^{-1} \frac{1}{99} = \frac{\pi}{4}$

(ii) $2 \tan^{-1} \frac{1}{5} + \sec^{-1} \frac{5\sqrt{2}}{7} + 2 \tan^{-1} \frac{1}{8} = \frac{\pi}{4}$

Solution : (i) $4 \tan^{-1} \frac{1}{5} - \tan^{-1} \frac{1}{70} + \tan^{-1} \frac{1}{99} = 2 \left\{ 2 \tan^{-1} \frac{1}{5} \right\} - \tan^{-1} \frac{1}{70} + \tan^{-1} \frac{1}{99}$

$$= 2 \left\{ \tan^{-1} \frac{2 \times 1/5}{1 - (1/5)^2} \right\} - \tan^{-1} \frac{1}{70} + \tan^{-1} \frac{1}{99} \quad \left[\begin{array}{l} \because 2 \tan^{-1} x \\ = \tan^{-1} \frac{2x}{1-x^2}, \text{ if } |x| < 1 \end{array} \right]$$

$$= 2 \tan^{-1} \frac{5}{12} - \left\{ \tan^{-1} \frac{1}{70} - \tan^{-1} \frac{1}{99} \right\} = \tan^{-1} \left\{ \frac{2 \times 5/12}{1 - (5/12)^2} \right\} - \tan^{-1} \left\{ \frac{\frac{1}{70} - \frac{1}{99}}{1 + \frac{1}{70} \times \frac{1}{99}} \right\}$$

$$= \tan^{-1} \frac{120}{119} - \tan^{-1} \frac{29}{6931} = \tan^{-1} \frac{120}{119} - \tan^{-1} \frac{1}{239} = \tan^{-1} \left\{ \frac{\frac{120}{119} - \frac{1}{239}}{1 + \frac{120}{119} \times \frac{1}{239}} \right\} = \tan^{-1} 1 = \frac{\pi}{4}$$

(ii) $2 \tan^{-1} \frac{1}{5} + \sec^{-1} \frac{5\sqrt{2}}{7} + 2 \tan^{-1} \frac{1}{8} = 2 \left\{ \tan^{-1} \frac{1}{5} + \tan^{-1} \frac{1}{8} \right\} + \sec^{-1} \frac{5\sqrt{2}}{7}$

$$= 2 \tan^{-1} \left\{ \frac{\frac{1}{5} + \frac{1}{8}}{1 - \frac{1}{5} \times \frac{1}{8}} \right\} + \tan^{-1} \sqrt{\left(\frac{5\sqrt{2}}{7} \right)^2 - 1} \quad \left[\because \sec^{-1} x = \tan^{-1} \sqrt{x^2 - 1} \right]$$

$$= 2 \tan^{-1} \frac{13}{39} + \tan^{-1} \frac{1}{7} = 2 \tan^{-1} \frac{1}{3} + \tan^{-1} \frac{1}{7}$$

$$= \tan^{-1} \left\{ \frac{2 \times 1/3}{1 - (1/3)^2} \right\} + \tan^{-1} \frac{1}{7} \quad \left[\because 2 \tan^{-1} x = \tan^{-1} \frac{2x}{1-x^2}, \text{ if } |x| < 1 \right]$$

$$= \tan^{-1} \frac{3}{4} + \tan^{-1} \frac{1}{7} = \tan^{-1} \left\{ \frac{\frac{3}{4} + \frac{1}{7}}{1 - \frac{3}{4} \times \frac{1}{7}} \right\} = \tan^{-1} 1 = \frac{\pi}{4}$$

Do yourself - 6 :

Prove the following results :

(i) $2 \tan^{-1} \left(\frac{1}{5} \right) + \tan^{-1} \left(\frac{1}{8} \right) = \tan^{-1} \left(\frac{4}{7} \right)$

(ii) $2 \sin^{-1} \left(\frac{3}{5} \right) - \tan^{-1} \left(\frac{17}{31} \right) = \frac{\pi}{4}$

6. EQUATIONS INVOLVING INVERSE TRIGONOMETRIC FUNCTIONS :

Illustration 15 : The equation $2 \cos^{-1} x + \sin^{-1} x = \frac{11\pi}{6}$ has

- (A) no solution (B) only one solution (C) two solutions (D) three solutions

Solution : Given equation is $2 \cos^{-1} x + \sin^{-1} x = \frac{11\pi}{6}$

$$\Rightarrow \cos^{-1} x + (\cos^{-1} x + \sin^{-1} x) = \frac{11\pi}{6} \Rightarrow \cos^{-1} x + \frac{\pi}{2} = \frac{11\pi}{6} \Rightarrow \cos^{-1} x = 4\pi/3$$

which is not possible as $\cos^{-1} x \in [0, \pi]$

Ans.(A)

Illustration 16 : If $(\tan^{-1} x)^2 + (\cot^{-1} x)^2 = 5\pi^2/8$, then x is equal to-

- (A) -1 (B) 0 (C) 1 (D) none of these

Solution : The given equation can be written as $(\tan^{-1} x + \cot^{-1} x)^2 - 2 \tan^{-1} x \cot^{-1} x = 5\pi^2/8$

Since $\tan^{-1} x + \cot^{-1} x = \pi/2$ we have

$$(\pi/2)^2 - 2 \tan^{-1} x (\pi/2 - \tan^{-1} x) = 5\pi^2/8$$

$$\Rightarrow 2(\tan^{-1} x)^2 - 2(\pi/2) \tan^{-1} x - 3\pi^2/8 = 0 \Rightarrow \tan^{-1} x = -\pi/4 \Rightarrow x = -1 \quad \text{Ans. (A)}$$

Illustration 17: Solve the equation : $\tan^{-1} \frac{x-1}{x-2} + \tan^{-1} \frac{x+1}{x+2} = \frac{\pi}{4}$

Solution: $\tan^{-1} \frac{x-1}{x-2} + \tan^{-1} \frac{x+1}{x+2} = \frac{\pi}{4}$

taking tangent on both sides

$$\Rightarrow \tan \left(\tan^{-1} \left(\frac{x-1}{x-2} \right) + \tan^{-1} \left(\frac{x+1}{x+2} \right) \right) = 1 \Rightarrow \frac{\tan \left(\tan^{-1} \left(\frac{x-1}{x-2} \right) \right) + \tan \left(\tan^{-1} \left(\frac{x+1}{x+2} \right) \right)}{1 - \tan \left(\tan^{-1} \left(\frac{x-1}{x-2} \right) \right) \tan \left(\tan^{-1} \left(\frac{x+1}{x+2} \right) \right)} = 1$$

$$\Rightarrow \frac{\frac{x-1}{x-2} + \frac{x+1}{x+2}}{1 - \frac{x-1}{x-2} \cdot \frac{x+1}{x+2}} = 1 \Rightarrow \frac{(x-1)(x+2) + (x-2)(x+1)}{x^2 - 4 - (x^2 - 1)} = 1 \Rightarrow 2x^2 - 4 = -3 \Rightarrow x = \pm \frac{1}{\sqrt{2}}$$

Now verify $x = \frac{1}{\sqrt{2}}$

$$= \tan^{-1} \left(\frac{\frac{1}{\sqrt{2}} - 1}{\frac{1}{\sqrt{2}} - 2} \right) + \tan^{-1} \left(\frac{\frac{1}{\sqrt{2}} + 1}{\frac{1}{\sqrt{2}} + 2} \right) = \tan^{-1} \left(\frac{\sqrt{2} - 1}{2\sqrt{2} - 1} \right) + \tan^{-1} \left(\frac{\sqrt{2} + 1}{2\sqrt{2} + 1} \right)$$

$$= \tan^{-1} \left(\frac{(2\sqrt{2} + 1)(\sqrt{2} - 1) + (2\sqrt{2} - 1)(\sqrt{2} + 1)}{(2\sqrt{2} - 1)(2\sqrt{2} + 1) - (\sqrt{2} - 1)(\sqrt{2} + 1)} \right) = \tan^{-1} \left(\frac{6}{6} \right) = \tan^{-1}(1) = \frac{\pi}{4}$$

$$x = -\frac{1}{\sqrt{2}}$$

$$= \tan^{-1} \left(\frac{-\frac{1}{\sqrt{2}} - 1}{-\frac{1}{\sqrt{2}} - 2} \right) + \tan^{-1} \left(\frac{-\frac{1}{\sqrt{2}} + 1}{-\frac{1}{\sqrt{2}} + 2} \right) = \tan^{-1} \left(\frac{\sqrt{2} + 1}{2\sqrt{2} + 1} \right) + \tan^{-1} \left(\frac{\sqrt{2} - 1}{2\sqrt{2} - 1} \right) \text{ \{same as above\}}$$

$$= \tan^{-1}(1) = \frac{\pi}{4}$$

$\therefore x = \pm \frac{1}{\sqrt{2}}$ are solutions

Ans.

Illustration 18: Solve the equation : $2 \tan^{-1}(2x + 1) = \cos^{-1}x$.

Solution: Here, $2 \tan^{-1}(2x + 1) = \cos^{-1}x$

$$\text{or } \cos(2 \tan^{-1}(2x + 1)) = x \quad \left\{ \text{We know } \cos 2\theta = \frac{1 - \tan^2 \theta}{1 + \tan^2 \theta} \right\}$$

$$\therefore \frac{1 - (2x + 1)^2}{1 + (2x + 1)^2} = x \Rightarrow (1 - 2x - 1)(1 + 2x + 1) = x(4x^2 + 4x + 2)$$

$$\begin{aligned} \Rightarrow -2x \cdot 2(x+1) &= 2x(2x^2 + 2x + 1) \Rightarrow 2x(2x^2 + 2x + 1 + 2x + 2) = 0 \\ \Rightarrow 2x(2x^2 + 4x + 3) &= 0 \\ \Rightarrow x=0 \text{ or } 2x^2 + 4x + 3 &= 0 \quad \{\text{No solution}\} \end{aligned}$$

Verify $x = 0$

$$2\tan^{-1}(1) = \cos^{-1}(1) \Rightarrow \frac{\pi}{2} = \frac{\pi}{2}$$

$\therefore x = 0$ is only the solution

Ans.

Do yourself - 7 :

Solve the following equation for x :

(i) $\sin\left[\sin^{-1}\left(\frac{1}{5}\right) + \cos^{-1}x\right] = 1$

(ii) $\cos^{-1}x + \sin^{-1}\frac{x}{2} = \frac{\pi}{6}$

7. INEQUATIONS INVOLVING INVERSE TRIGONOMETRIC FUNCTION :

Illustration 19 : Find the complete solution set of $\sin^{-1}(\sin 5) > x^2 - 4x$.

Solution :

$$\begin{aligned} \sin^{-1}(\sin 5) > x^2 - 4x &\Rightarrow \sin^{-1}[\sin(5 - 2\pi)] > x^2 - 4x \\ \Rightarrow x^2 - 4x < 5 - 2\pi &\Rightarrow x^2 - 4x + (2\pi - 5) < 0 \\ \Rightarrow 2 - \sqrt{9 - 2\pi} < x < 2 + \sqrt{9 - 2\pi} &\Rightarrow x \in (2 - \sqrt{9 - 2\pi}, 2 + \sqrt{9 - 2\pi}) \end{aligned}$$

Ans.

Illustration 20 : Find the complete solution set of $[\cot^{-1}x]^2 - 6[\cot^{-1}x] + 9 \leq 0$, where $[.]$ denotes the greatest integer function.

Solution :

$$\begin{aligned} [\cot^{-1}x]^2 - 6[\cot^{-1}x] + 9 &\leq 0 \\ \Rightarrow ([\cot^{-1}x] - 3)^2 &\leq 0 \Rightarrow [\cot^{-1}x] = 3 \Rightarrow 3 \leq \cot^{-1}x < 4 \Rightarrow x \in (-\infty, \cot 3] \end{aligned}$$

Illustration 21 : If $\cot^{-1}\frac{n}{\pi} > \frac{\pi}{6}$, $n \in \mathbb{N}$, then the maximum value of n is -

- (A) 1 (B) 5 (C) 9 (D) none of these

Solution :

$$\begin{aligned} \cot^{-1}\frac{n}{\pi} > \frac{\pi}{6} \\ \Rightarrow \cot\left(\cot^{-1}\left(\frac{n}{\pi}\right)\right) < \cot\left(\frac{\pi}{6}\right) &\Rightarrow \frac{n}{\pi} < \sqrt{3} \\ \Rightarrow n < \pi\sqrt{3} &\Rightarrow n < 5.5 \text{ (approx)} \\ \Rightarrow n = 5 &\quad \because (n \in \mathbb{N}) \end{aligned}$$

Ans. (B)

Do yourself - 8 :

- (i) Solve the inequality $\tan^{-1}x > \cot^{-1}x$.
 (ii) Complete solution set of inequation $(\cos^{-1}x)^2 - (\sin^{-1}x)^2 > 0$, is

- (A) $\left[0, \frac{1}{\sqrt{2}}\right)$ (B) $\left[-1, \frac{1}{\sqrt{2}}\right)$ (C) $(-1, \sqrt{2})$ (D) none of these

8. SUMMATION OF SERIES :

Illustration 22 : Prove that :

$$\tan^{-1}\left(\frac{c_1x-y}{c_1y+x}\right) + \tan^{-1}\left(\frac{c_2-c_1}{1+c_2c_1}\right) + \tan^{-1}\left(\frac{c_3-c_2}{1+c_3c_2}\right) + \dots + \tan^{-1}\left(\frac{c_n-c_{n-1}}{1+c_nc_{n-1}}\right) + \tan^{-1}\left(\frac{1}{c_n}\right) = \tan^{-1}\left(\frac{x}{y}\right)$$

Solution : L.H.S.

$$\tan^{-1}\left(\frac{c_1x-y}{c_1y+x}\right) + \tan^{-1}\left(\frac{c_2-c_1}{1+c_2c_1}\right) + \tan^{-1}\left(\frac{c_3-c_2}{1+c_3c_2}\right) + \dots + \tan^{-1}\left(\frac{c_n-c_{n-1}}{1+c_nc_{n-1}}\right) + \tan^{-1}\left(\frac{1}{c_n}\right)$$

$$= \tan^{-1}\left(\frac{\frac{x}{y} - \frac{1}{c_1}}{1 + \frac{x}{y} \cdot \frac{1}{c_1}}\right) + (\tan^{-1}c_2 - \tan^{-1}c_1) + (\tan^{-1}c_3 - \tan^{-1}c_2) + \dots + (\tan^{-1}c_n - \tan^{-1}c_{n-1}) + \tan^{-1}\left(\frac{1}{c_n}\right)$$

$$= \tan^{-1}\left(\frac{x}{y}\right) - \tan^{-1}\left(\frac{1}{c_1}\right) - \tan^{-1}c_1 + \tan^{-1}c_n + \tan^{-1}\left(\frac{1}{c_n}\right)$$

$$= \tan^{-1}\left(\frac{x}{y}\right) - (\cot^{-1}c_1 + \tan^{-1}c_1) + (\tan^{-1}c_n + \cot^{-1}c_n)$$

$$= \tan^{-1}\left(\frac{x}{y}\right) - \frac{\pi}{2} + \frac{\pi}{2} = \tan^{-1}\left(\frac{x}{y}\right) = \text{R.H.S.}$$

Do yourself - 9 :

- (i) Evaluate : $\sum_{r=1}^{\infty} \tan^{-1}\left(\frac{2}{1+(2r+1)(2r-1)}\right)$

Miscellaneous Illustrations :

Illustration 23 : If $\tan^{-1} y = 4 \tan^{-1} x$, $\left(|x| < \tan \frac{\pi}{8} \right)$, find y as an algebraic function of x and hence prove

that $\tan \frac{\pi}{8}$ is a root of the equation $x^4 - 6x^2 + 1 = 0$.

Solution :

We have $\tan^{-1} y = 4 \tan^{-1} x$

$$\Rightarrow \tan^{-1} y = 2 \tan^{-1} \frac{2x}{1-x^2} \quad (\text{as } |x| < 1)$$

$$= \tan^{-1} \frac{\frac{4x}{1-x^2}}{1 - \frac{4x^2}{(1-x^2)^2}} = \tan^{-1} \frac{4x(1-x^2)}{x^4 - 6x^2 + 1} \quad \left(\text{as } \left| \frac{2x}{1-x^2} \right| < 1 \right)$$

$$\Rightarrow y = \frac{4x(1-x^2)}{x^4 - 6x^2 + 1}$$

If $x = \tan \frac{\pi}{8}$

$$\Rightarrow \tan^{-1} y = 4 \tan^{-1} x = \frac{\pi}{2} \Rightarrow y \text{ is not defined} \Rightarrow x^4 - 6x^2 + 1 = 0 \quad \text{Ans.}$$

Illustration 24 : If $A = 2 \tan^{-1}(2\sqrt{2} - 1)$ and $B = 3 \sin^{-1}(1/3) + \sin^{-1}(3/5)$, then show $A > B$.

Solution :

We have, $A = 2 \tan^{-1}(2\sqrt{2} - 1) = 2 \tan^{-1}(1.828)$

$$\Rightarrow A > 2 \tan^{-1}(\sqrt{3}) \Rightarrow A > \frac{2\pi}{3} \quad \dots\dots (i)$$

also we have, $\sin^{-1}\left(\frac{1}{3}\right) < \sin^{-1}\left(\frac{1}{2}\right) \Rightarrow \sin^{-1}\left(\frac{1}{3}\right) < \frac{\pi}{6}$

$$\Rightarrow 3 \sin^{-1}\left(\frac{1}{3}\right) < \frac{\pi}{2}$$

also, $3 \sin^{-1}\left(\frac{1}{3}\right) = \sin^{-1}\left(3 \cdot \frac{1}{3} - 4\left(\frac{1}{3}\right)^3\right) = \sin^{-1}\left(\frac{23}{27}\right) = \sin^{-1}(0.852)$

$$\Rightarrow 3 \sin^{-1}(1/3) < \sin^{-1}(\sqrt{3}/2) \Rightarrow 3 \sin^{-1}(1/3) < \pi/3$$

also, $\sin^{-1}(3/5) = \sin^{-1}(0.6) < \sin^{-1}(\sqrt{3}/2) \Rightarrow \sin^{-1}(3/5) < \pi/3$

Hence, $B = 3 \sin^{-1}(1/3) + \sin^{-1}(3/5) < \frac{2\pi}{3} \quad \dots\dots (ii)$

From (i) and (ii), we have $A > B$.

Illustration 25 : If $\theta = \tan^{-1}(2 \tan^2\theta) - \frac{1}{2} \sin^{-1}\left(\frac{3 \sin 2\theta}{5 + 4 \cos 2\theta}\right)$ then find the sum of all possible values of $\tan\theta$.

Solution :

$$\theta = \tan^{-1}(2 \tan^2\theta) - \frac{1}{2} \sin^{-1}\left(\frac{3 \sin 2\theta}{5 + 4 \cos 2\theta}\right) \Rightarrow \theta = \tan^{-1}(2 \tan^2\theta) - \frac{1}{2} \sin^{-1}\left(\frac{6 \tan \theta}{9 + \tan^2 \theta}\right)$$

$$\Rightarrow \theta = \tan^{-1}(2 \tan^2\theta) - \frac{1}{2} \sin^{-1}\left[\frac{2\left(\frac{1}{3} \tan \theta\right)}{1 + \left(\frac{1}{3} \tan \theta\right)^2}\right] \Rightarrow \theta = \tan^{-1}(2 \tan^2\theta) - \frac{2}{2} \tan^{-1}\left(\frac{1}{3} \tan \theta\right)$$

$$\Rightarrow \theta = \tan^{-1}(2 \tan^2\theta) - \tan^{-1}\left(\frac{1}{3} \tan \theta\right) \quad \dots\dots (i)$$

taking tangent on both sides

$$\Rightarrow \tan \theta = \frac{6 \tan^2 \theta - \tan \theta}{3 + 2 \tan^3 \theta} \Rightarrow 2 \tan^4 \theta - 6 \tan^2 \theta + 4 \tan \theta = 0$$

$$\Rightarrow 2 \tan \theta (\tan^3 \theta - 3 \tan \theta + 2) = 0 \Rightarrow 2 \tan \theta (\tan \theta - 1)^2 (\tan \theta + 2) = 0$$

$$\Rightarrow \tan \theta = 0, 1, -2 \quad \text{which satisfy equation (i)}$$

$$\therefore \text{sum} = 0 + 1 - 2 = -1$$

Ans.

ANSWERS FOR DO YOURSELF

- | | | | |
|------------|--|----------------------------|---------------------------------|
| 1 : | (i) C | (ii) 1526 | |
| 2 : | (i) $\frac{15}{8}$ | (ii) $\frac{1}{\sqrt{10}}$ | (iii) 1 (iv) $\frac{4}{5}$ |
| 3 : | (i) $\frac{\pi}{6}$ | (ii) $\frac{\pi}{6}$ | (iii) $\frac{\pi}{6}$ |
| 4 : | (ii) $\begin{cases} 1, & \text{if } a > 0 \\ -1, & \text{if } a < 0 \end{cases}$ | | |
| 7 : | (i) $\frac{1}{5}$ | (ii) 1 | (iii) $\sqrt{3}$ |
| 8 : | (i) $(1, \infty)$ | (ii) B | |
| 9 : | (i) $\pi/4$ | | |

EXERCISE (O-1)

Straight Objective Type

1. The domain of the function $\sin^{-1}\left(\log_2\left(\frac{x}{3}\right)\right)$ is-
- (A) $\left[\frac{1}{2}, 3\right]$ (B) $\left[\frac{1}{2}, 3\right]$ (C) $\left[\frac{3}{2}, 6\right]$ (D) $\left[\frac{1}{2}, 2\right]$
2. Domain of the function $f(x) = \log_e \cos^{-1}\{\sqrt{x}\}$ is, where $\{.\}$ represents fractional part function -
- (A) $x \in \mathbb{R}$ (B) $x \in [0, \infty)$ (C) $x \in (0, \infty)$ (D) $x \in \mathbb{R} - \{x \mid x \in \mathbb{I}\}$
3. $\tan^{-1}\left(1 - x^2 - \frac{1}{x^2}\right) + \sin^{-1}\left(x^2 + \frac{1}{x^2} - 1\right)$ (where $x \neq 0$) is equal to
- (A) $\frac{\pi}{2}$ (B) $\frac{\pi}{4}$ (C) $\frac{3\pi}{4}$ (D) π
4. The value of $\tan^2(\sec^{-1}3) + \cot^2(\operatorname{cosec}^{-1}4)$ is -
- (A) 9 (B) 16 (C) 25 (D) 23
5. If $x > 0$ $\cos^{-1}\left(\frac{12}{x}\right) = \frac{\pi}{2} - \cos^{-1}\left(\frac{16}{x}\right)$ then x is -
- (A) 12 (B) 16 (C) 20 (D) 320
6. If $2 \leq a < 3$, then the value of $\cos^{-1} \cos[a] + \operatorname{cosec}^{-1} \operatorname{cosec}[a] + \cot^{-1} \cot[a]$, (where $[\cdot]$ denotes greatest integer less than equal to x) is equal to
- (A) $2 - \pi$ (B) $2 + \pi$ (C) π (D) 6
7. If $\cos^{-1}(2x^2 - 1) = 2\pi - 2\cos^{-1}x$, then -
- (A) $x \in [-1, 0]$ (B) $x \in [0, 1]$ (C) $x \in \left[0, \frac{1}{\sqrt{2}}\right]$ (D) $x \in \left[-\frac{1}{\sqrt{2}}, \frac{1}{\sqrt{2}}\right]$
8. Number of integral ordered pairs (a, b) for which $\sin^{-1}(1 + b + b^2 + \dots \infty) + \cos^{-1}\left(a - \frac{a^2}{3} + \frac{a^3}{9} - \dots \infty\right) = \frac{\pi}{2}$ is-
- (A) 0 (B) 4 (C) 9 (D) Infinitely many
9. $\lim_{n \rightarrow \infty} \sum_{r=1}^n \tan^{-1} \frac{2r+1}{r^4 + 2r^3 + r^2 + 1}$ is equal to -
- (A) $\frac{\pi}{4}$ (B) $\frac{3\pi}{4}$ (C) $\frac{\pi}{2}$ (D) $-\frac{\pi}{8}$

Multiple Correct Answer Type

10. If $\sin\left(2\cos^{-1}\left(\frac{1}{\sqrt{5}}\right)\right) + \cos\left(2\tan^{-1}\left(\frac{1}{3}\right)\right) = \frac{p}{q}$, where p & q are relatively prime then digit at units place of $(p - q)^{2k+1}$, $k \in \mathbb{N}$, can be -
 (A) 1 (B) 3 (C) 7 (D) 9
11. Consider the function $f(x) = e^x$ and $g(x) = \sin^{-1}x$, then which of the following is/are necessarily true.
 (A) Domain of $g \circ f =$ Domain of f (B) Range of $g \circ f \subset$ Range of g
 (C) Domain of $g \circ f$ is $(-\infty, 0]$ (D) Range of $g \circ f$ is $\left[-\frac{\pi}{2}, 0\right)$
12. Let $f(x) = \sin^{-1}(\tan x) + \cos^{-1}(\cot x)$ then
 (A) $f(x) = \frac{\pi}{2}$ wherever defined (B) domain of $f(x)$ is $x = n\pi \pm \frac{\pi}{4}$, $n \in \mathbb{I}$
 (C) period of $f(x)$ is $\frac{\pi}{2}$ (D) $f(x)$ is many one function
13. Let $f(x) = e^{x^3 - x^2 + x}$ be an invertible function such that $f^{-1} = g$, then -
 (A) $g(e) = 0$ (B) Domain of 'g' is \mathbb{R}^+
 (C) Range of 'g' is \mathbb{R} (D) $f(g(e)) = e$
14. Value of $3\tan^{-1}\left(\frac{1}{3}\right) + \tan^{-1}\left(\frac{1}{2}\right) + \sin^{-1}\left(\frac{1}{\sqrt{5}}\right) + \cos^{-1}\left(\frac{2}{\sqrt{5}}\right)$ is greater than
 (A) $\frac{\pi}{2}$ (B) $\frac{2\pi}{3}$ (C) $\frac{3\pi}{4}$ (D) $\frac{5\pi}{6}$
15. Which of the following is/are correct ?
 (A) $\cot^{-1}(x) = \tan^{-1}\left(\frac{1}{x}\right) \forall x \in \mathbb{R} - \{0\}$
 (B) If $f : \mathbb{R} \rightarrow \mathbb{R}$ such that $f(x) = \operatorname{sgn}(e^x)$ then $f(x)$ is an into function.
 (C) If $f : \mathbb{R}^+ \rightarrow \mathbb{R}$ such that $f(x) = \sin x + x$ then $f(x)$ is an odd function.
 (D) If $f : \mathbb{R} \rightarrow \mathbb{R}$ such that $f(x) = \frac{e^x}{e^{\lfloor x \rfloor}}$ then $f(x)$ is a periodic function .
 (where $\lfloor . \rfloor$ represents greatest integer function)

EXERCISE (O-2)

Straight Objective Type

1. The range of the function $f(x) = \sin^{-1}(\log_2(-x^2 + 2x + 3))$ is -
 (A) $\left[-\frac{\pi}{2}, \frac{\pi}{2}\right]$ (B) $\left[-\frac{\pi}{2}, 0\right]$ (C) $\left[0, \frac{\pi}{2}\right]$ (D) $[-1, 1]$
2. Range of $f(x) = \cot^{-1}(\log_e(1 - x^2))$ is -
 (A) $(0, \pi)$ (B) $\left(0, \frac{\pi}{2}\right)$ (C) $\left[\frac{\pi}{2}, \pi\right)$ (D) $\left(0, \frac{\pi}{2}\right]$
3. The value of $\sin^{-1}\left\{\cot\left(\sin^{-1}\sqrt{\frac{2-\sqrt{3}}{4}} + \cos^{-1}\frac{\sqrt{12}}{4} + \sec^{-1}\sqrt{2}\right)\right\}$ is -
 (A) 5 (B) 6 (C) 0 (D) 10
4. Number of solution(s) of the equation $\cos^{-1}\sqrt{x} - \sin^{-1}\sqrt{x-1} + \cos^{-1}\sqrt{1-x} - \sin^{-1}\frac{1}{\sqrt{x}} = \frac{\pi}{2}$ is -
 (A) 0 (B) 1 (C) 2 (D) 4
5. $\sum_{r=0}^{\infty} \tan^{-1}\left(\frac{r(r+1)!}{(r+1) + ((r+1)!)^2}\right)$ is equal to -
 (A) $\frac{\pi}{2}$ (B) $\frac{\pi}{4}$ (C) $\cot^{-1}3$ (D) $\tan^{-1}2$

Multiple Correct Answer Type

6. Let $f(x) = \sqrt{\cos^{-1}\sqrt{1-x^2} - \sin^{-1}x}$ then which of the following statement/s is/are correct -
 (A) Domain of $f(x)$ is $[-1, 1]$ (B) Domain of $f(x)$ is $[0, 1]$
 (C) Range of $f(x)$ is $\{0\}$ (D) Range of $f(x)$ is $[0, \sqrt{\pi}]$
7. If $\alpha = 2 \tan^{-1}(\sqrt{3-2\sqrt{2}}) + \sin^{-1}\left(\frac{1}{\sqrt{6}-\sqrt{2}}\right)$, $\beta = \cot^{-1}(\sqrt{3}-2) + \frac{1}{8} \sec^{-1}(-2)$ & $\gamma = \tan^{-1}\frac{1}{\sqrt{2}} + \cos^{-1}\frac{1}{\sqrt{3}}$, then
 (A) $\alpha = \beta$ (B) $\alpha + \beta = 3\gamma$ (C) $4(\beta - \gamma) = \alpha$ (D) $\beta = \gamma$
8. If α is only real root of the equation $x^3 + (\cos 1)x^2 + (\sin 1)x + 1 = 0$, then $\left(\tan^{-1}\alpha + \tan^{-1}\frac{1}{\alpha}\right)$ cannot be equal to -
 (A) 0 (B) $\frac{\pi}{2}$ (C) $-\frac{\pi}{2}$ (D) π
9. Let $f(x) = \begin{cases} x^2 - 4 & \text{if } |x| \leq 3 \\ 5 \operatorname{sgn}|x-3| & \text{if } |x| > 3 \end{cases}$ and $g(x) = 2 \tan^{-1}(e^x) - \frac{\pi}{2}$ for all $x \in \mathbb{R}$, then which of the following is wrong?
 (where $\operatorname{sgn}(x)$ denotes signum function of x)
 (A) $f(x)$ is an even function (B) $g \circ f(x)$ is an even function
 (C) $g(x)$ is an odd function (D) $f \circ g(x)$ is an odd function

Linked Comprehension Type

Paragraph for Question 10 to 12

Consider a continuous function such that each image has atmost three preimage & atleast one image has exactly three preimages. This type of function is to be called as three-one function.

On the basis of above information, answer the following questions :

10. Which of the following function is a three-one function ?
 (A) $|\ln|x||$ (B) $e^{|x|}$ (C) $x^3 + 3x^2 - 7x + 6$ (D) $\cos(\cos^{-1}x)$
11. If $f(x) = \sin^{-1}(\sin x)$ is a three-one function, then possible interval of x is -
 (A) $[-\pi, \pi]$ (B) $\left[-\frac{\pi}{2}, \frac{3\pi}{2}\right]$ (C) $(-2\pi, 0]$ (D) $\left[\frac{-3\pi}{2}, \frac{\pi}{2}\right]$
12. If $f(x)$ is a three-one function such that $f(a) = f(b)$ (where $a \neq b$), then number of maximum possible values of b is -
 (A) 1 (B) 2 (C) 3 (D) 4

Subjective Type Questions

13. Least integral value of x for which inequality $\sin^{-1}\left(\sin\left(\frac{2e^x + 3}{e^x + 1}\right)\right) > \pi - \frac{5}{2}$ holds, is
14. The product of all real values of x satisfying the equation $\sin^{-1} \cos\left(\frac{2x^2 + 10|x| + 4}{x^2 + 5|x| + 3}\right) = \cot\left(\cot^{-1}\left(\frac{2 - 18|x|}{9|x|}\right)\right) + \frac{\pi}{2}$ is
15. Number of integral solutions of the equation $2\sin^{-1}\sqrt{x^2 - x + 1} + \cos^{-1}\sqrt{x^2 - x} = \frac{3\pi}{2}$ is
16. If $\sin^{-1}\sin\left(\frac{10\pi}{3}\right) + \cos^{-1}\cos\frac{22\pi}{3} + \tan^{-1}\tan 10 = a\pi + b$, then $\left|\frac{3ab}{80}\right|$ is equal to

EXERCISE (S-1)

1. Given is a partial graph of an even periodic function f whose period is 8.

If $[*]$ denotes greatest integer function then find the value of the expression.

$$f(-3) + 2|f(-1)| + \left[f\left(\frac{7}{8}\right)\right] + f(0) + \arccos(f(-2)) + f(-7) + f(20)$$

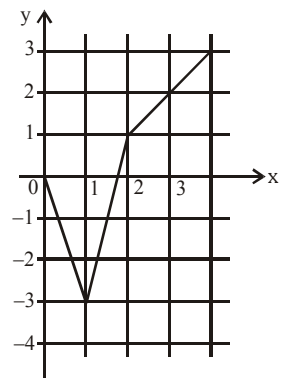

2. (a) Find the following :
- (i) $\tan\left[\cos^{-1}\frac{1}{2} + \tan^{-1}\left(\frac{-1}{\sqrt{3}}\right)\right]$ (ii) $\cos^{-1}\left(\cos\frac{7\pi}{6}\right)$
- (iii) $\cos\left(\tan^{-1}\frac{3}{4}\right)$ (iv) $\tan\left(\sin^{-1}\frac{3}{5} + \cot^{-1}\frac{3}{2}\right)$

(b) Find the following :

$$(i) \quad \sin \left[\frac{\pi}{2} - \sin^{-1} \left(\frac{-\sqrt{3}}{2} \right) \right]$$

$$(ii) \quad \cos \left[\cos^{-1} \left(\frac{-\sqrt{3}}{2} \right) + \frac{\pi}{6} \right]$$

$$(iii) \quad \tan^{-1} \left(\tan \frac{3\pi}{4} \right)$$

$$(iv) \quad \sin \left(\frac{1}{4} \arcsin \frac{\sqrt{63}}{8} \right)$$

3. Find the domain of definition the following functions.

(Read the symbols $[*]$ and $\{ * \}$ as greatest integers and fractional part functions respectively)

$$(i) \quad f(x) = \arccos \frac{2x}{1+x}$$

$$(ii) \quad f(x) = \sqrt{\cos(\sin x)} + \sin^{-1} \frac{1+x^2}{2x}$$

$$(iii) \quad f(x) = \sin^{-1} \left(\frac{x-3}{2} \right) - \log_{10} (4-x)$$

$$(iv) \quad f(x) = \sin^{-1}(2x + x^2)$$

$$(v) \quad f(x) = \frac{\sqrt{1-\sin x}}{\log_5(1-4x^2)} + \cos^{-1}(1-\{x\}), \text{ where } \{x\} \text{ is the fractional part of } x.$$

$$(vi) \quad f(x) = \sqrt{3-x} + \cos^{-1} \left(\frac{3-2x}{5} \right) + \log_6(2|x|-3) + \sin^{-1}(\log_2 x)$$

$$(vii) \quad f(x) = e^{\sin^{-1} \left(\frac{x}{2} \right)} + \tan^{-1} \left[\frac{x}{2} - 1 \right] + \ln(\sqrt{x - [x]})$$

4. Identify the pair(s) of functions which are identical. Also plot the graphs in each case.

$$(a) \quad y = \tan(\cos^{-1} x); y = \frac{\sqrt{1-x^2}}{x}$$

$$(b) \quad y = \tan(\cot^{-1} x); y = \frac{1}{x}$$

$$(c) \quad y = \sin(\arcsin x); y = \frac{x}{\sqrt{1+x^2}}$$

$$(d) \quad y = \cos(\arcsin x); y = \sin(\arcsin x)$$

5. Let $y = \sin^{-1}(\sin 8) - \tan^{-1}(\tan 10) + \cos^{-1}(\cos 12) - \sec^{-1}(\sec 9) + \cot^{-1}(\cot 6) - \operatorname{cosec}^{-1}(\operatorname{cosec} 7)$. If y simplifies to $a\pi + b$, then find $(a - b)$.

$$6. \quad \text{Show that : } \sin^{-1} \left(\sin \frac{33\pi}{7} \right) + \cos^{-1} \left(\cos \frac{46\pi}{7} \right) + \tan^{-1} \left(-\tan \frac{13\pi}{8} \right) + \cot^{-1} \left(\cot \left(-\frac{19\pi}{8} \right) \right) = \frac{13\pi}{7}$$

$$7. \quad \text{Prove that : (a) } 2 \cos^{-1} \frac{3}{\sqrt{13}} + \cot^{-1} \frac{16}{63} + \frac{1}{2} \cos^{-1} \frac{7}{25} = \pi \quad (b) \quad \arcsin \frac{\sqrt{2}}{3} - \arcsin \frac{\sqrt{6+1}}{2\sqrt{3}} = \frac{\pi}{6}$$

8. If α and β are the roots of the equation $x^2 + 5x - 49 = 0$, then find the value of $\cot(\cot^{-1}\alpha + \cot^{-1}\beta)$.

$$9. \quad \text{If } a > b > c > 0, \text{ then find the value of : } \cot^{-1} \left(\frac{1+ab}{a-b} \right) + \cot^{-1} \left(\frac{1+bc}{b-c} \right) + \cot^{-1} \left(\frac{1+ca}{c-a} \right).$$

10. Find all values of k for which there is a triangle whose angles have measure $\tan^{-1} \left(\frac{1}{2} \right), \tan^{-1} \left(\frac{1}{2} + k \right)$ and $\tan^{-1} \left(\frac{1}{2} + 2k \right)$.

11. Find the simplest value of

(a) $f(x) = \arccos x + \arccos\left(\frac{x}{2} + \frac{1}{2}\sqrt{3-3x^2}\right)$, $x \in \left(\frac{1}{2}, 1\right)$

(b) $f(x) = \tan^{-1}\left(\frac{\sqrt{1+x^2}-1}{x}\right)$, $x \in \mathbb{R} - \{0\}$

12. Prove that the identities :

(a) $\sin^{-1}\cos(\sin^{-1}x) + \cos^{-1}\sin(\cos^{-1}x) = \frac{\pi}{2}$, $|x| \leq 1$

(d) $\tan(\tan^{-1}x + \tan^{-1}y + \tan^{-1}z) = \cot(\cot^{-1}x + \cot^{-1}y + \cot^{-1}z)$

13. (a) Solve the inequality : $(\arccos x)^2 - 6(\arccos x) + 8 > 0$

(b) If $\sin^2 x + \sin^2 y < 1$; $x, y \in \mathbb{R}$ then prove that $\sin^{-1}(\tan x \cdot \tan y) \in (-\pi/2, \pi/2)$.

14. Solve the following :

(a) $\sin^{-1} x + \sin^{-1} 2x = \frac{\pi}{3}$

(b) $\tan^{-1} \frac{1}{1+2x} + \tan^{-1} \frac{1}{1+4x} = \tan^{-1} \frac{2}{x^2}$

(c) $\tan^{-1}(x-1) + \tan^{-1}(x) + \tan^{-1}(x+1) = \tan^{-1}(3x)$

(d) $3\cos^{-1} x = \sin^{-1}(\sqrt{1-x^2}(4x^2-1))$

(e) $\sin^{-1} x + \sin^{-1} y = \frac{2\pi}{3}$ & $\cos^{-1} x - \cos^{-1} y = \frac{\pi}{3}$

15. Find the sum of the series :

(a) $\cot^{-1}7 + \cot^{-1}13 + \cot^{-1}21 + \cot^{-1}31 + \dots$ to n terms.

(b) $\tan^{-1} \frac{1}{3} + \tan^{-1} \frac{2}{9} + \dots + \tan^{-1} \frac{2^{n-1}}{1+2^{2n-1}} + \dots$ ∞

(c) $\tan^{-1} \frac{1}{x^2+x+1} + \tan^{-1} \frac{1}{x^2+3x+3} + \tan^{-1} \frac{1}{x^2+5x+7} + \tan^{-1} \frac{1}{x^2+7x+13}$ to n terms.

(d) $\sin^{-1} \frac{1}{\sqrt{5}} + \sin^{-1} \frac{1}{\sqrt{65}} + \sin^{-1} \frac{1}{\sqrt{325}} + \dots + \sin^{-1} \frac{1}{\sqrt{4n^4+1}} + \dots$ ∞ terms.

EXERCISE (S-2)

1. If $\alpha = 2 \arctan\left(\frac{1+x}{1-x}\right)$ & $\beta = \arcsin\left(\frac{1-x^2}{1+x^2}\right)$ for $0 < x < 1$, then prove that $\alpha + \beta = \pi$, what the value of $\alpha + \beta$ will be if $x > 1$.

2. Solve the following :

(a) $\tan^{-1} \frac{x-1}{x+1} + \tan^{-1} \frac{2x-1}{2x+1} = \tan^{-1} \frac{23}{36}$

(b) $2 \tan^{-1} x = \cos^{-1} \frac{1-a^2}{1+a^2} - \cos^{-1} \frac{1-b^2}{1+b^2}$ ($a > 0$, $b > 0$)

3. If α and β are the roots of the equation $x^2 - 4x + 1 = 0$ ($\alpha > \beta$) then find the value of

$$f(\alpha, \beta) = \frac{\beta^3}{2} \operatorname{cosec}^2\left(\frac{1}{2} \tan^{-1} \frac{\beta}{\alpha}\right) + \frac{\alpha^3}{2} \sec^2\left(\frac{1}{2} \tan^{-1} \frac{\alpha}{\beta}\right).$$

4. Find all the positive integral solutions of, $\tan^{-1}x + \cos^{-1} \frac{y}{\sqrt{1+y^2}} = \sin^{-1} \frac{3}{\sqrt{10}}$.

5. Prove that the equation, $(\sin^{-1}x)^3 + (\cos^{-1}x)^3 = \alpha\pi^3$ has no roots for $\alpha < \frac{1}{32}$ and $\alpha > \frac{7}{8}$.
6. Solve the following inequalities :
 (a) $\text{arc cot}^2x - 5 \text{ arc cot } x + 6 > 0$ (b) $\text{arc sin } x > \text{arc cos } x$ (c) $\tan^2(\text{arc sin } x) > 1$
7. Solve the following system of inequalities :
 $4 \text{ arc tan}^2x - 8 \text{ arc tan } x + 3 < 0$ & $4 \text{ arc cot } x - \text{arc cot}^2x - 3 \geq 0$
8. If the sum $\sum_{n=1}^{10} \sum_{m=1}^{10} \tan^{-1}\left(\frac{m}{n}\right) = k\pi$, find the value of k.
9. Show that the roots r, s and t of the cubic $x(x-2)(3x-7) = 2$, are real and positive. Also compute the value of $\tan^{-1}(r) + \tan^{-1}(s) + \tan^{-1}(t)$.
10. Solve for x : $\sin^{-1}\left(\sin\left(\frac{2x^2+4}{1+x^2}\right)\right) < \pi - 3$.
11. Find the set of values of 'a' for which the equation $2\cos^{-1}x = a + a^2(\cos^{-1}x)^{-1}$ posses a solution.

EXERCISE (JM)

1. Let $f : (-1, 1) \rightarrow B$, be a function defined by $f(x) = \tan^{-1} \frac{2x}{1-x^2}$, then f is both one-one and onto when B is the interval- [AIEEE-2005]
- (1) $\left[-\frac{\pi}{2}, \frac{\pi}{2}\right]$ (2) $\left(-\frac{\pi}{2}, \frac{\pi}{2}\right)$ (3) $\left(0, \frac{\pi}{2}\right)$ (4) $\left[0, \frac{\pi}{2}\right]$
2. If $\cos^{-1}x - \cos^{-1} \frac{y}{2} = \alpha$, then $4x^2 - 4xy \cos \alpha + y^2$ is equal to - [AIEEE-2005]
- (1) $2 \sin 2\alpha$ (2) 4 (3) $4 \sin^2\alpha$ (4) $-4 \sin^2\alpha$
3. If $\sin^{-1}\left(\frac{x}{5}\right) + \text{cosec}^{-1}\left(\frac{5}{4}\right) = \frac{\pi}{2}$, then a value of x is- [AIEEE-2007]
- (1) 1 (2) 3 (3) 4 (4) 5
4. The value of $\cot\left(\text{cosec}^{-1} \frac{5}{3} + \tan^{-1} \frac{2}{3}\right)$ is equal to- [AIEEE-2008]
- (1) $\frac{6}{17}$ (2) $\frac{3}{17}$ (3) $\frac{4}{17}$ (4) $\frac{5}{17}$
5. If x, y, z are in A.P. and $\tan^{-1}x, \tan^{-1}y$ and $\tan^{-1}z$ are also in A.P., then [JEE (Main)-2013]
- (1) $x = y = z$ (2) $2x = 3y = 6z$ (3) $6x = 3y = 2z$ (4) $6x = 4y = 3z$
6. Let $\tan^{-1} y = \tan^{-1} x + \tan^{-1}\left(\frac{2x}{1-x^2}\right)$, where $|x| < \frac{1}{\sqrt{3}}$. Then a value of y is : [JEE (Main)-2015]
- (1) $\frac{3x-x^3}{1+3x^2}$ (2) $\frac{3x+x^3}{1+3x^2}$ (3) $\frac{3x-x^3}{1-3x^2}$ (4) $\frac{3x+x^3}{1-3x^2}$

EXERCISE (JA)

1. Let (x, y) be such that $\sin^{-1}(ax) + \cos^{-1}(y) + \cos^{-1}(bxy) = \frac{\pi}{2}$ [JEE 2007, 6]

Match the statements in column-I with statements in column-II and indicate your answer by darkening the appropriate bubbles in the 4×4 matrix given in the ORS.

Column-I

- (A) If $a = 1$ and $b = 0$, then (x, y)
 (B) If $a = 1$ and $b = 1$, then (x, y)
 (C) If $a = 1$ and $b = 2$, then (x, y)
 (D) If $a = 2$ and $b = 2$, then (x, y)

Column-II

- (p) lies on the circle $x^2 + y^2 = 1$
 (q) lies on $(x^2 - 1)(y^2 - 1) = 0$
 (r) lies on $y = x$
 (s) lies on $(4x^2 - 1)(y^2 - 1) = 0$

2. If $0 < x < 1$, then $\sqrt{1+x^2} [\{x \cos(\cot^{-1}x) + \sin(\cot^{-1}x)\}^2 - 1]^{1/2} =$ [JEE 2008, 3]

- (A) $\frac{x}{\sqrt{1+x^2}}$ (B) x (C) $x\sqrt{1+x^2}$ (D) $\sqrt{1+x^2}$

3. The value of $\cot\left(\sum_{n=1}^{23} \cot^{-1}\left(1 + \sum_{k=1}^n 2k\right)\right)$ is [JEE(Advanced) 2013, 2]

- (A) $\frac{23}{25}$ (B) $\frac{25}{23}$ (C) $\frac{23}{24}$ (D) $\frac{24}{23}$

4. Match List-I with List-II and select the correct answer using the code given below the lists.

List-I

P. $\left(\frac{1}{y^2} \left(\frac{\cos(\tan^{-1}y) + y \sin(\tan^{-1}y)}{\cot(\sin^{-1}y) + \tan(\sin^{-1}y)}\right)^2 + y^4\right)^{1/2}$ takes value

Q. If $\cos x + \cos y + \cos z = 0 = \sin x + \sin y + \sin z$,
 then possible value of $\cos \frac{x-y}{2}$ is

R. If $\cos\left(\frac{\pi}{4} - x\right) \cos 2x + \sin x \sin 2x \sec x$
 $= \cos x \sin 2x \sec x + \cos\left(\frac{\pi}{4} + x\right) \cos 2x$,
 then possible value of $\sec x$ is

S. If $\cot\left(\sin^{-1}\sqrt{1-x^2}\right) = \sin\left(\tan^{-1}(x\sqrt{6})\right)$, $x \neq 0$,
 then possible value of x is

List-II

1. $\frac{1}{2}\sqrt{\frac{5}{3}}$

2. $\sqrt{2}$

3. $\frac{1}{2}$

4. 1

Codes :

- | | | | | |
|-----|---|---|---|---|
| | P | Q | R | S |
| (A) | 4 | 3 | 1 | 2 |
| (B) | 4 | 3 | 2 | 1 |
| (C) | 3 | 4 | 2 | 1 |
| (D) | 3 | 4 | 1 | 2 |

[JEE(Advanced) 2013, 3, (-1)]

5. Let $f : [0, 4\pi] \rightarrow [0, \pi]$ be defined by $f(x) = \cos^{-1}(\cos x)$. The number of points $x \in [0, 4\pi]$ satisfying the equation $f(x) = \frac{10-x}{10}$ is [JEE(Advanced)-2014, 3]

6. If $\alpha = 3 \sin^{-1}\left(\frac{6}{11}\right)$ and $\beta = 3 \cos^{-1}\left(\frac{4}{9}\right)$ where the inverse trigonometric functions take only the principal values, then the correct option(s) is(are) [JEE(Advanced)-2015, 4]

- (A) $\cos \beta > 0$ (B) $\sin \beta < 0$ (C) $\cos(\alpha + \beta) > 0$ (D) $\cos \alpha < 0$

7. The number of real solutions of the equation

$$\sin^{-1}\left(\sum_{i=1}^{\infty} x^{i+1} - x \sum_{i=1}^{\infty} \left(\frac{x}{2}\right)^i\right) = \frac{\pi}{2} - \cos^{-1}\left(\sum_{i=1}^{\infty} \left(-\frac{x}{2}\right)^i - \sum_{i=1}^{\infty} (-x)^i\right)$$
 lying in the interval $\left(-\frac{1}{2}, \frac{1}{2}\right)$ is ____

(Here, the inverse trigonometric functions $\sin^{-1}x$ and $\cos^{-1}x$ assume value in $\left[-\frac{\pi}{2}, \frac{\pi}{2}\right]$ and $[0, \pi]$, respectively.) [JEE(Advanced)-2018]

8. Let $E_1 = \left\{x \in \mathbb{R} : x \neq 1 \text{ and } \frac{x}{x-1} > 0\right\}$ and $E_2 = \left\{x \in E_1 : \sin^{-1}\left(\log_e\left(\frac{x}{x-1}\right)\right) \text{ is a real number}\right\}$.

(Here, the inverse trigonometric function $\sin^{-1}x$ assumes values in $\left[-\frac{\pi}{2}, \frac{\pi}{2}\right]$.)

Let $f : E_1 \rightarrow \mathbb{R}$ be the function defined by $f(x) = \log_e\left(\frac{x}{x-1}\right)$

and $g : E_2 \rightarrow \mathbb{R}$ be the function defined by $g(x) = \sin^{-1}\left(\log_e\left(\frac{x}{x-1}\right)\right)$.

LIST-I

- P.** The range of f is
Q. The range of g contains
R. The domain of f contains
S. The domain of g is

LIST-II

1. $\left(-\infty, \frac{1}{1-e}\right] \cup \left[\frac{e}{e-1}, \infty\right)$
2. $(0, 1)$
3. $\left[-\frac{1}{2}, \frac{1}{2}\right]$
4. $(-\infty, 0) \cup (0, \infty)$
5. $\left(-\infty, \frac{e}{e-1}\right]$
6. $(-\infty, 0) \cup \left(\frac{1}{2}, \frac{e}{e-1}\right]$

The correct option is :

- (A) **P** \rightarrow **4**; **Q** \rightarrow **2**; **R** \rightarrow **1**; **S** \rightarrow **1**
 (B) **P** \rightarrow **3**; **Q** \rightarrow **3**; **R** \rightarrow **6**; **S** \rightarrow **5**
 (C) **P** \rightarrow **4**; **Q** \rightarrow **2**; **R** \rightarrow **1**; **S** \rightarrow **6**
 (D) **P** \rightarrow **4**; **Q** \rightarrow **3**; **R** \rightarrow **6**; **S** \rightarrow **5**

[JEE(Advanced)-2018]

ANSWER KEY

FUNCTIONS

EXERCISE (O-1)

1. (i) $-\infty < x \leq 0$ (ii) $x \in \mathbb{R}$ (iii) $x \in \mathbb{R} - \{-1, 0, 1\}$
 (iv) $-\infty < x < 0$ & $4 < x < \infty$ (v) $-\infty < x \leq 1$ and $3 \leq x < \infty$ (vi) $-\infty < x < 1$ and $2 < x < \infty$
 (vii) $-1 \leq x \leq 1$ (viii) $0 < x < 1$ and $1 < x < \infty$. (ix) $-2 \leq x < 0$ and $0 < x < 1$
 (x) $\frac{3}{2} < x < 2$ and $2 < x < \infty$. (xi) $-1 < x < 0$ and $1 < x < 2$; $2 < x < \infty$
 (xii) $2k\pi < x < (2k + 1)\pi$, where k is an integer. (xiii) $4 \leq x \leq 6$ (xiv) $2 < x < 3$
2. (i) $\mathbb{R} - \{1\}$ (ii) $\mathbb{R} - \{0\}$ (iii) $(0, 4/3]$ (iv) $[1/3, 3]$ (v) $[1, \infty)$ (vi) \mathbb{R}
 (vii) $[0, \infty)$ (viii) $[3, 7]$ (ix) $[-1, 1]$ (x) $[2, \infty)$ (xi) $[1/3, 1)$ (xii) $\left[\frac{1}{11}, \frac{1}{5}\right]$
3. (a) -2, (b) -3, 1, (c) $[-3, 3], [-2, 3]$, (d) $(-1, 3]$, (e) B, (f) A, D

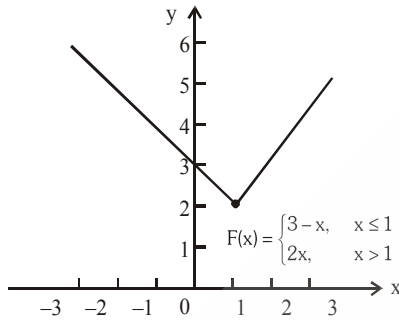

4. $F(x) = \begin{cases} 3-x, & x \leq 1 \\ 2x, & x > 1 \end{cases}$
5. (a) $y = \begin{cases} x, & 0 \leq x \leq 1 \\ 2-x, & 1 < x \leq 2 \end{cases}$ (b) $y = \begin{cases} 2, & 0 \leq x < 1 \text{ and } 2 \leq x < 3 \\ 0, & 1 \leq x < 2 \text{ and } 3 \leq x \leq 4 \end{cases}$
6. (a) -2, 4, (b) -2, 2, (c) -3, 4, (d) $(0, 4]$ (e) $[-4, 4], [-2, 3]$ (f) $[-4, 3], [0.5, 4]$
7. (a) $\left[\frac{4}{3}, \frac{5}{3}\right] \cup \{3\}$ (b) $[-2, -1) \cup [1, 3]$ (c) $[-3, -2] \cup [-1, 1]$ (d) $\left(\frac{5}{3}, 3\right) - \{2\}$
8. C 9. D 10. C 11. A 12. C 13. B 14. C
 15. C 16. D 17. B 18. C 19. A 20. C 21. D
 22. B 23. D 24. B 25. B 26. C 27. D 28. D
 29. D 30. C 31. B,C 32. A,C 33. A,B,C,D 34. A,B,C
 35. A,B,C 36. A,B,C 37. A,B,C
 38. (A) \rightarrow (P,R,T); (B) \rightarrow (Q,R); (C) \rightarrow (Q,S); (D) \rightarrow (P,R,T) 39. A 40. C

EXERCISE (O-2)

1. C 2. B 3. D 4. C 5. B 6. A 7. B
 8. A 9. D 10. A 11. B 12. D 13. B 14. C
 15. D 16. B 17. C 18. A 19. A,B,C 20. A,C
 21. B,C,D 22. A,D 23. A,C 24. B,C,D 25. B,C
 26. C,D 27. B,C 28. A,B,C 29. A,B,C,D 30. A,C
 31. B 32. C 33. C 34. (A) \rightarrow (P,S); (B) \rightarrow (R); (C) \rightarrow (Q,S); (D) \rightarrow (T)
 35. (A) \rightarrow (P,R,T); (B) \rightarrow (Q,R,T); (C) \rightarrow (Q,R,T); (D) \rightarrow (P,R,T)

EXERCISE (S-1)

1. (i) $\left[-\frac{5\pi}{4}, -\frac{3\pi}{4}\right] \cup \left[-\frac{\pi}{4}, \frac{\pi}{4}\right] \cup \left[\frac{3\pi}{4}, \frac{5\pi}{4}\right]$ (ii) $\left(-4, -\frac{1}{2}\right) \cup (2, \infty)$ (iii) $(-\infty, -3]$
 (iv) $(-\infty, -1) \cup [0, \infty)$ (v) $(3 - 2\pi < x < 3 - \pi) \cup (3 < x \leq 4)$
 (vi) $\left(0, \frac{1}{100}\right) \cup \left(\frac{1}{100}, \frac{1}{\sqrt{10}}\right)$
 (vii) $(-3, -1] \cup \{0\} \cup [1, 3)$ (viii) $\{4\} \cup [5, \infty)$ (ix) $(1, 2) \cup (2, 5/2)$ (x) $x \in \{4, 5\}$
2. (i) $D : x \in \mathbb{R} \quad R : [0, 2]$ (ii) $D = \mathbb{R}; \text{range } [-1, 1]$
 (iii) $D : \{x \mid x \in \mathbb{R}; x \neq -3; x \neq 2\} \quad R : \{f(x) \mid f(x) \in \mathbb{R}, f(x) \neq 1/5; f(x) \neq 1\}$
 (iv) $D : \mathbb{R}, R : (-1, 1)$ (v) $D : -1 \leq x \leq 2 \quad R : [\sqrt{3}, \sqrt{6}]$
 (vi) $D : [-4, \infty) - \{5\}; R : \left(0, \frac{1}{6}\right) \cup \left(\frac{1}{6}, \frac{1}{3}\right]$
3. (b) (i), (iii) are identical
4. (a) neither surjective nor injective (b) surjective but not injective
 (c) neither injective nor surjective
5. (a) $-3/4$; (b) 64; (c) 30, (d) 5050
6. (a) domain is $x \geq 0$; range $[-1, 1]$; (b) domain $2k\pi \leq x \leq 2k\pi + \pi$; range $[0, 1]$
 (c) domain $x \in \mathbb{R}$; range $[-\sin 1, \sin 1]$ (d) domain is $0 \leq x \leq 1$; range is $[0, 1]$
8. (a) $\frac{(x+3)^{10}}{(x+3)^{10}+1}$, domain is \mathbb{R} , $\frac{1024}{1025}$; (b) $g(x) = \begin{cases} \frac{1}{x^2} & \text{if } 0 < x \leq 1 \\ x^2 & \text{if } x > 1 \end{cases}$
9. $f^{-1}(1) = y$ 10. $(\text{gof})(x) = \begin{cases} x & \text{if } x \leq 0 \\ -x^2 & \text{if } 0 < x < 1 \\ 1-x^2 & \text{if } x \geq 1 \end{cases}$; $(\text{fog})(x) = \begin{cases} x^2 & \text{if } x < 0 \\ 1+x & \text{if } 0 \leq x < 1 \\ x & \text{if } x \geq 1 \end{cases}$
11. (a) odd, (b) even, (c) neither odd nor even, (d) odd, (e) neither odd nor even,
 (f) even, (g) even, (h) even
12. (i) (a) $y = \log(10 - 10^x)$, $-\infty < x < 1$
 (b) $y = x/3$ when $-\infty < x < 0$ & $y = x$ when $0 \leq x < +\infty$
 (ii) (a) $2K\pi \leq x \leq 2K\pi + \pi$ where $K \in \mathbb{I}$ (b) $[-3/2, -1]$
 (iii) (a) Range : $[-1/3, 3]$, Domain = $[4, 7]$; (b) Range $[-1, 9]$ and domain $[11, 14]$
13. (a) $\frac{e^x - e^{-x}}{2}$; (b) $\frac{\log_2 x}{\log_2 x - 1}$; (c) $\frac{1}{2} \log \frac{1+x}{1-x}$
14. $x = 10$; $f^{-1}(x) = 10^{\log_2(x-8)}$
15. (a) (i) Period of fog is π , period of gof is 2π (ii) range of fog is $[-1, 1]$, range of gof is $[-\tan 1, \tan 1]$
 (b) 0.86
16. (A) S; (B) R; (C) P; (D) Q 17. (A) \rightarrow (Q); (B) \rightarrow (R); (C) \rightarrow (P); (D) \rightarrow (S)
18. 6 19. 401 20. 9 21. 6 22. 4024 23. 2 24. 15
 25. 6 26. 9

EXERCISE (S-2)

1. (i) $(0, 1/4) \cup (3/4, 1) \cup \{x : x \in \mathbb{N}, x \geq 2\}$ (ii) $\mathbb{R} - \left\{-\frac{1}{2}, 0\right\}$
2. (a) 727, (b) 3 3. 6016 4. $f(x) = 2x^2$
5. $f \circ g(x) = \begin{cases} -(1+x), & -1 \leq x \leq 0 \\ x-1, & 0 < x \leq 2 \end{cases}; g \circ f(x) = \begin{cases} x+1, & 0 \leq x < 1 \\ 3-x, & 1 \leq x \leq 2 \\ x-1, & 2 < x \leq 3 \\ 5-x, & 3 < x \leq 4 \end{cases}$
- $f \circ f(x) = \begin{cases} x, & 0 \leq x \leq 1 \\ 4-x, & 3 \leq x \leq 4 \end{cases}; g \circ g(x) = \begin{cases} -x, & -1 \leq x \leq 0 \\ x, & 0 < x \leq 2 \\ 4-x, & 2 < x \leq 3 \end{cases}$
6. 21
7. $x = 0$ या $5/3$ 8. 1002.5 9. 5049 10. 20
11. 122 12. D 13. A 14. C 15. $\{-1, 1\}$

EXERCISE (JM)

1. 1 2. 1 3. 3 4. 1 5. 4 6. 4 7. 2

EXERCISE (JA)

1. A 2. A 3. B 4. (zero marks to all) 5. A,B,C

INVERSE TRIGONOMETRIC FUNCTIONS

EXERCISE (O-1)

1. C 2. B 3. B 4. D 5. C 6. B 7. A
8. A 9. A 10. B,C 11. B,C 12. A,B,C,D 13. B,C,D
14. A,B 15. B,D

EXERCISE (O-2)

1. A 2. C 3. C 4. A 5. B 6. A,D
7. A,C 8. A,B,D 9. D 10. C 11. A 12. B
13. 1 14. 9 15. 2 16. 1

EXERCISE (S-1)

1. 5
2. (a) (i) $\frac{1}{\sqrt{3}}$, (ii) $\frac{5\pi}{6}$, (iii) $\frac{4}{5}$, (iv) $\frac{17}{6}$; (b) (i) $\frac{1}{2}$, (ii) -1 , (iii) $-\frac{\pi}{4}$, (iv) $\frac{\sqrt{2}}{4}$
3. (i) $-1/3 \leq x \leq 1$ (ii) $\{1, -1\}$ (iii) $1 \leq x < 4$ (iv) $[-(1+\sqrt{2}), (\sqrt{2}-1)]$
 (v) $x \in (-1/2, 1/2), x \neq 0$ (vi) $(3/2, 2]$ (vii) $(-2, 2) - \{-1, 0, 1\}$

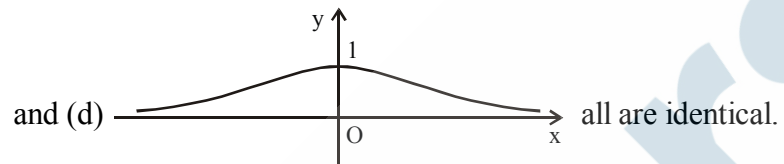
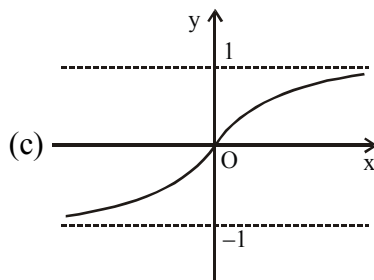
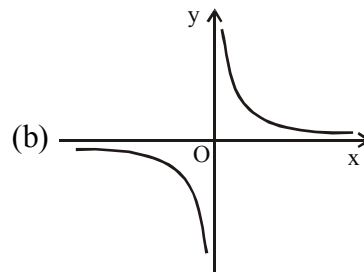
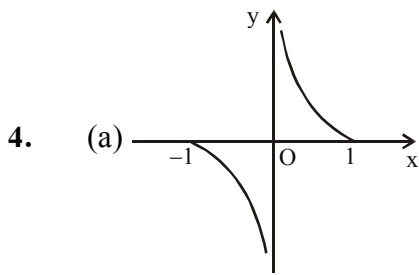

5. 53 8. 10 9. π 10. $k = \frac{11}{4}$ 11. (a) $\frac{\pi}{3}$; (b) $\frac{1}{2} \tan^{-1} x$

13. (a) $(-\infty, \sec 2) \cup [1, \infty)$

14. (a) $x = \frac{1}{2} \sqrt{\frac{3}{7}}$; (b) $x = 3$; (c) $x = 0, \frac{1}{2}, -\frac{1}{2}$; (d) $\left[\frac{\sqrt{3}}{2}, 1\right]$; (e) $x = \frac{1}{2}, y = 1$

15. (a) $\operatorname{arccot} \left[\frac{2n+5}{n} \right]$, (b) $\frac{\pi}{4}$, (c) $\operatorname{arc} \tan(x+n) - \operatorname{arc} \tan x$, (d) $\frac{\pi}{4}$

EXERCISE (S-2)

1. $-\pi$ 2. (a) $x = \frac{4}{3}$; (b) $x = \frac{a-b}{1+ab}$; 3. 56 4. $x = 1; y = 2$ & $x = 2; y = 7$

6. (a) $(\cot 2, \infty) \cup (-\infty, \cot 3)$ (b) $\left(\frac{\sqrt{2}}{2}, 1\right]$ (c) $\left(\frac{\sqrt{2}}{2}, 1\right) \cup \left(-1, -\frac{\sqrt{2}}{2}\right)$

7. $\left(\tan \frac{1}{2}, \cot 1\right]$ 8. $k = 25$ 9. $\frac{3\pi}{4}$ 10. $x \in (-1, 1)$

11. $a \in [-2\pi, \pi] - \{0\}$

EXERCISE (JM)

1. 2 2. 3 3. 2 4. 1 5. 1 6. 3

EXERCISE (JA)

1. (A) P; (B) Q; (C) P; (D) S 2. C 3. B 4. B 5. 3
6. B,C,D 7. 2 8. A