

PHYSICS
JEE-MAIN (August-Attempt)
31 August (Shift-2) Paper

SECTION - A

1. A current of 1.5 A is flowing through a triangle, of side 9 cm each. The magnetic field at the centroid of the triangle is:

(Assume that the current is flowing in the clockwise direction)

- (1) $2\sqrt{3} \times 10^{-7}$, outside the plane of triangle
- (2) $3 \times 10^{-5} \text{ T}$, inside the plane of triangle
- (3) $3 \times 10^{-7} \text{ T}$, outside the plane of triangle
- (4) $2\sqrt{3} \times 10^{-5} \text{ T}$, inside the plane of triangle

Sol. (2)

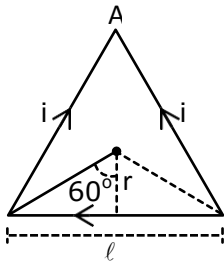

$$B = 3 \left[\frac{\mu_0 i}{4\pi r} (\sin 60^\circ + \sin 60^\circ) \right]$$

$$\tan 60^\circ = \frac{l/2}{r}$$

$$\text{where } r = \frac{9 \times 10^{-2}}{2\sqrt{3}} \text{ m}$$

$$\therefore B = 3 \times 10^{-5} \text{ T}$$

Current is flowing in clockwise direction so, B is inside plane of triangle by right hand rule.

2. The equivalent resistance of the given circuit between the terminals A and B is:

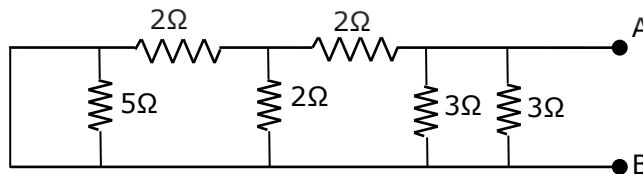

- (1) 1Ω
- (2) $\frac{9}{2}\Omega$
- (3) 0Ω
- (4) 3Ω

Sol. (1)

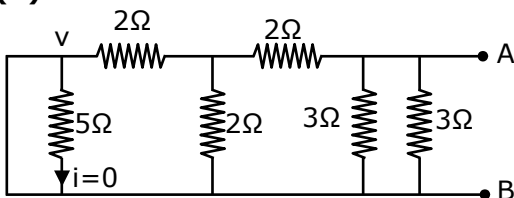

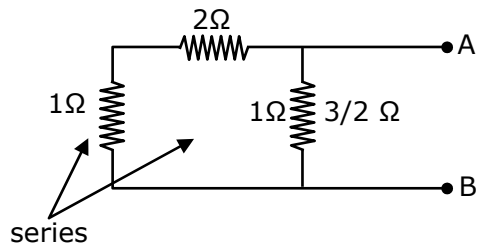
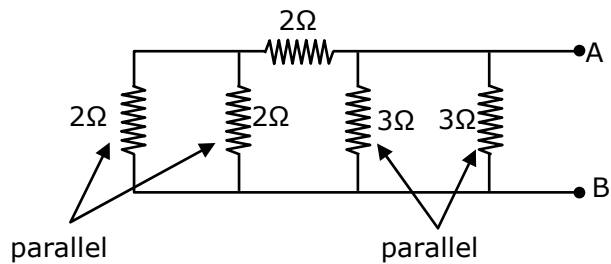

$$R_{eq} = \frac{3 \times 3/2}{3 + 3/2} = \frac{9/2}{9/2} = 1\Omega$$

3. Choose the incorrect statement:

- (a) The electric lines of force entering into Gaussian surface provide negative flux.
- (b) A charge 'q' is placed at the centre of a cube. The flux through all the faces will be the same
- (c) In a uniform electric field net flux through a closed Gaussian surface containing no net charge, is zero
- (d) When electric field is parallel to a Gaussian surface, it provides a finite non-zero flux.

Choose the most appropriate answer from the options given below:

- (1) (d) Only
- (2) (b) and (d) Only
- (3) (a) and (c) Only
- (4) (c) and (d) Only

Sol. (1)

$$\text{Since } \phi = \vec{E} \cdot \vec{A} = EA \cos\theta$$

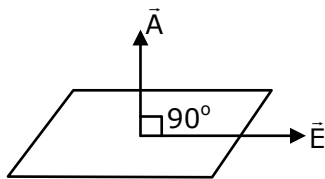

$$\theta = 90^\circ$$

$$\therefore \phi = 0$$

4. **Statement I:**

If three forces \vec{F}_1, \vec{F}_2 and \vec{F}_3 are represented by three sides of a triangle and $\vec{F}_1 + \vec{F}_2 = -\vec{F}_3$, then these three forces are concurrent forces and satisfy the condition for equilibrium.

Statement II:

A triangle made up of three forces \vec{F}_1, \vec{F}_2 and \vec{F}_3 as its sides taken in the same order, satisfy the condition for translatory equilibrium.

In the light of above statements, choose the most appropriate answer from the options given below:

- (1) Both Statement I and Statement II are true.
- (2) Statement I is true but Statement II is false.
- (3) Statement I is false but Statement II is true.
- (4) Both the Statement I and Statement II are false.

Sol. (3)

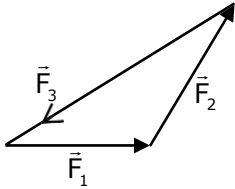

$$\text{Here } \vec{F}_1 + \vec{F}_2 + \vec{F}_3 = 0$$

$$\vec{F}_1 + \vec{F}_2 = -\vec{F}_3$$

Since $\vec{F}_{\text{net}} = 0$ (equilibrium)

Both statements correct

5. Statement I:

Two forces $(\vec{P} + \vec{Q})$ and $(\vec{P} - \vec{Q})$ where $\vec{P} \perp \vec{Q}$, when act at an angle θ_1 to each other, the magnitude of their resultant is $\sqrt{3(P^2 + Q^2)}$, when they act at an angle θ_2 , the magnitude of their resultant becomes $\sqrt{2(P^2 + Q^2)}$. This is possible only when $\theta_1 < \theta_2$.

Statement II:

In the situation given above.

$$\theta_1 = 60^\circ \text{ and } \theta_2 = 90^\circ$$

In the light of the above statements, choose the most appropriate answer from the options given below

- (1) Both Statement I and Statement II are false.
- (2) Both Statement I and Statement II are true.
- (3) Statement I is true but Statement II is false.
- (4) Statement I is false but Statement II is true.

Sol. (2)

$$\vec{A} = \vec{P} + \vec{Q}$$

$$\vec{B} = \vec{P} - \vec{Q} \quad \vec{P} \perp \vec{Q}$$

$$|\vec{A}| = |\vec{B}| = \sqrt{P^2 + Q^2}$$

$$|\vec{A}| = |\vec{B}| = \sqrt{2(P^2 + Q^2)(1 + \cos \theta)}$$

$$\text{For } |\vec{A} + \vec{B}| = \sqrt{3(P^2 + Q^2)}$$

$$\theta_1 = 60^\circ$$

$$\text{For } |\vec{A} + \vec{B}| = \sqrt{2(P^2 + Q^2)}$$

$$\theta_2 = 90^\circ$$

6. If V_A and V_B are the input voltages (either 5V or 0V) and V_0 is the output voltage then the two gates represented in the following circuits (A) and (B) are:

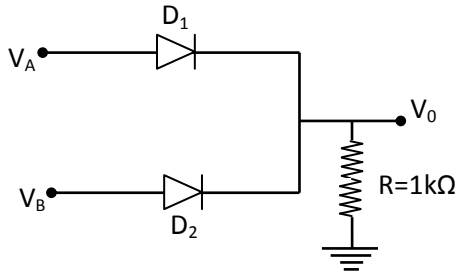

(A)

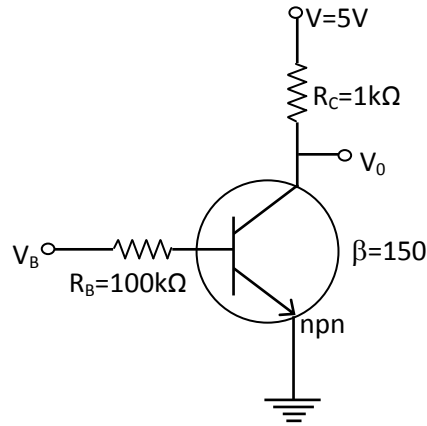

(B)

- (1) AND and NOT Gate
 (3) OR and NOT Gate

- (2) AND and OR Gate
 (4) NAND and NOR Gate

Sol. (3)

$$V_A = 5V \Rightarrow A = 1$$

$$V_A = 0V \Rightarrow A = 0$$

$$V_B = 5V \Rightarrow B = 1$$

$$V_B = 0V \Rightarrow B = 0$$

If $A = B = 0$, there is no potential anywhere here
 $V_0 = 0$

If $A = 1, B = 0$, Diode D_1 is forward biased, here $V_0 = 5V$

If $A = 0, B = 1$, Diode D_2 is forward biased hence $V_0 = 5V$

If $A = 1, B = 1$, Both diodes are forward biased hence $V_0 = 5V$

Truth table for 1st

A	B	Output
0	0	0
0	1	1
1	0	1
1	1	1

∴ Given circuit is OR gate

For IInd circuit

$$V_B = 5V, A = 1$$

$$V_B = 0V, A = 0$$

When $A = 0$, E-B junction is unbiased there is no current through it

$$\therefore V_0 = 1$$

When $A = 1$, E-B junction is forward biased

$$V_0 = 0$$

∴ Hence this circuit is not gate.

7. For a body executing S.H.M.:
- Potential energy is always equal to its K.E.
 - Average potential and kinetic energy over any given time interval are always equal.
 - Sum of the kinetic and potential energy at any point of time is constant.
 - Average KE. in one time period is equal to average potential energy in one time period.
- Choose the most appropriate option from the options given below
- only (b)
 - (c) and (d)
 - only (c)
 - (b) and (c)

Sol. (2)

In S.H.M. total mechanical energy remains constant and also

$$\langle \text{K.E.} \rangle = \langle \text{P.E.} \rangle = \frac{1}{4} K A^2$$

(for 1 time period)

8. Consider two separate ideal gases of electrons and protons having same number of particles. The temperae of both the gases are same. The ratio of the uncertainty in determining the position of an electron to that of a proton is proportional to:

- $\sqrt{\frac{m_e}{m_p}}$
- $\frac{m_p}{m_e}$
- $\left(\frac{m_p}{m_e}\right)^{3/2}$
- $\sqrt{\frac{m_p}{m_e}}$

Sol. (4)

$$\Delta x \cdot \Delta p \geq \frac{h}{4\pi}$$

$$\Delta x = \frac{h}{4\pi m \Delta v} \quad v = \sqrt{\frac{3KT}{m}}$$

$$\frac{\Delta x_e}{\Delta x_p} = \sqrt{\frac{m_p}{m_e}}$$

9. A coil is placed in a magnetic field \vec{B} as shown below:

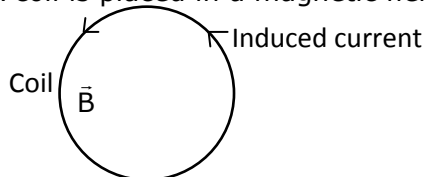

A current is induced in the coil because \vec{B} is:

- parallel to the plane of coil and increasing with time
- outward and increasing with time
- parallel to the plane of coil and decreasing with time
- outward and decreasing with time

Sol. (2)

\vec{B} must not be parallel to the plane of coil for non zero flux and according to lenz law if B is outward it should be decreasing for anticlockwise induced current.

10. If velocity [V] and time [T] and force [F] are chosen as the base quantities, the dimentions of the mass will be:

- [FTV⁻¹]
- [FT²V]
- [FVT⁻¹]
- [FT⁻¹V⁻¹]

Sol. (1)

$$[M] = K[F]^a [T]^b [V]^c$$
$$[M^1] = [M^1 L^1 T^{-2}]^a [T^1]^b [L^1 T^{-1}]^c$$
$$a = 1, b = 1, c = -1$$
$$\therefore [M] = [FTV^{-1}]$$

11. A block moving horizontally on a smooth surface with a speed of 40 m/s splits into two Parts with masses in the ratio of 1 : 2. If the smaller part moves at 60 m/s in the same direction, then the fractional change in kinetic energy is

- (1) $\frac{2}{3}$ (2) $\frac{1}{4}$ (3) $\frac{1}{3}$ (4) $\frac{1}{8}$

Sol. (4)

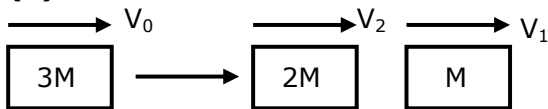

$$3MV_0 = 2MV_2 + MV_1$$
$$3V_0 = 2V_2 + V_1$$
$$120 = 2V_2 + 60 \Rightarrow V_2 = 30 \text{ m/s}$$

$$\frac{\Delta \text{K.E.}}{\text{K.E.}} = \frac{\frac{1}{2}MV_1^2 + \frac{1}{2}2MV_2^2 - \frac{1}{2}3MV_0^2}{\frac{1}{2}3MV_0^2}$$
$$= \frac{V_1^2 + 2V_2^2 - 3V_0^2}{3V_0^2}$$
$$= \frac{3600 + 1800 - 4800}{4800}$$
$$= \frac{1}{8}$$

12. Two thin metallic spherical shells of radii r_1 and r_2 ($r_1 < r_2$) are placed with their coinciding. A material of thermal conductivity K is filled in the space between the shells. The inner shell is maintained at temperature θ_1 and the outer shell at temperature θ_2 ($\theta_1 < \theta_2$). The rate at which heat flows radially through the material is :

- (1) $\frac{K(\theta_2 - \theta_1)}{r_2 - r_1}$ (2) $\frac{\pi r_1 r_2 (\theta_2 - \theta_1)}{r_2 - r_1}$ (3) $\frac{4\pi K r_1 r_2 (\theta_2 - \theta_1)}{r_2 - r_1}$ (4) $\frac{K(\theta_2 - \theta_1)(r_2 - r_1)}{4\pi r_1 r_2}$

Sol. (3)

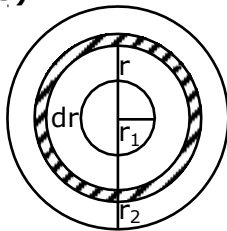

Thermal resistance of spherical sheet of thickness dr and radius r is

$$dR = \frac{dr}{K(4\pi r^2)}$$

$$R = \int_{r_1}^{r_2} \frac{dr}{K(4\pi r^2)}$$

$$R = \frac{1}{4\pi K} \left(\frac{1}{r_1} - \frac{1}{r_2} \right) = \frac{1}{4\pi K} \left(\frac{r_2 - r_1}{r_1 r_2} \right)$$

$$\text{Thermal current (i)} = \frac{\theta_2 - \theta_1}{R}$$

$$i = \frac{4\pi K r_1 r_2}{r_2 - r_1} (\theta_2 - \theta_1)$$

- 13.** The magnetic field vector of an electromagnetic wave is given by $B = B_0 \frac{\hat{i} + \hat{j}}{\sqrt{2}} \cos(kz - \omega t)$; where \hat{i}, \hat{j} represents unit vector along x and y-axis respectively. At $t=0$ s, two electric charges q_1 of 4π coulomb and q_2 of 2π coulomb located at $\left(0, 0, \frac{\pi}{k}\right)$ and $\left(0, 0, \frac{3\pi}{k}\right)$ respectively, have the same velocity of $0.5c \hat{i}$, (where c is the velocity of light). The ratio of the force acting on charge q_1 to q_2 is:

(1) $1 : \sqrt{2}$

(2) $2 : 1$

(3) $\sqrt{2} : 1$

(4) $2\sqrt{2} : 1$

Sol.

(3)

$$\vec{F} = q(\vec{V} \times \vec{B})$$

$$\vec{F}_1 = 4\pi \left[0.5c\hat{i} \times B_0 \left(\frac{\hat{i} + \hat{j}}{2} \right) \cos \left(K \cdot \frac{\pi}{K} - 0 \right) \right]$$

$$\vec{F}_2 = 2\pi \left[0.5c\hat{i} \times B_0 \left(\frac{\hat{i} + \hat{j}}{2} \right) \cos \left(K \cdot \frac{3\pi}{K} - 0 \right) \right]$$

$$\cos \pi = -1, \quad \cos 3\pi = -1$$

$$\therefore \frac{F_1}{F_2} = 2$$

14. Statement I:

To get a steady dc output from the pulsating voltages received from a full wave rectifier we can connect a capacitor across the output parallel to the load R_L .

Statement II:

To get a steady dc output from the pulsating voltage received from the full wave rectifier we can connect an inductor in series with R_L .

In the light of the above statements, choose the most appropriate answer from the options given below:

- (1) Both Statement I and Statement II are true.
- (2) Both Statement I and Statement II are false.
- (3) Statement I is true but Statement II is false.
- (4) Statement I is false but Statement II is true.

Sol. (1)

To convert pulsating dc into steady dc both of mentioned method are correct.

- 15.** Four identical hollow cylindrical columns of mild steel support a big structure of mass 50×10^3 kg. The inner and outer radii of each column are 50 cm and 100 cm respectively. Assuming uniform local distribution, calculate the compression strain of each column [use $Y = 2.0 \times 10^{11}$ Pa, $g = 9.8$ m/s²]
- (1) 2.60×10^{-7} (2) 1.87×10^{-3} (3) 7.07×10^{-4} (4) 3.60×10^{-8}

Sol. (1)

$$\text{Force on each column} = \frac{mg}{4}$$

$$\begin{aligned} \text{Strain} &= \frac{mg}{4AY} \\ &= \frac{50 \times 10^3 \times 9.8}{4 \times \pi (1 - 0.25) \times 2 \times 10^{11}} \\ &= 2.6 \times 10^{-7} \end{aligned}$$

- 16.** A system consists of two identical spheres each of mass 1.5 kg and radius 50 cm at the ends of a light rod. The distance between the centres of the two spheres is 5 m. What will be the moment of inertia of the system about an axis perpendicular to the rod passing through its midpoint?
- (1) 19.05 kgm² (2) 18.75 kgm² (3) 1.875×10^5 kgm² (4) 1.905×10^5 kgm²

Sol. (1)



$$M = 1.5 \text{ kg}, r = 0.5 \text{ m}, d = \frac{5}{2} \text{ m}$$

$$\begin{aligned} I &= 2 \left(\frac{2}{5} Mr^2 + Md^2 \right) \\ &= 19.05 \text{ kgm}^2 \end{aligned}$$

- 17.** A bob of mass 'm' suspended by a thread of length l undergoes simple harmonic oscillations with time period T. If the bob is immersed in a liquid that has density $\frac{1}{4}$ times that of the bob and the length of the thread is increased by $\frac{1}{3}$ rd of the original length, then the time period of the simple harmonic oscillations will be:
- (1) T (2) $\frac{3}{2}T$ (3) $\frac{3}{4}T$ (4) $\frac{4}{3}T$

Sol. (4)

$$T = 2\pi\sqrt{\ell/g}$$

When bob is immersed in liquid

$mg_{\text{eff}} = mg - \text{Buoyant force}$

$$mg_{\text{eff}} = mg - v\sigma g \quad (\sigma = \text{density of liquid})$$

$$= mg - v \frac{\rho}{4} g$$

$$= mg - \frac{mg}{4} = \frac{3mg}{4}$$

$$\therefore g_{\text{eff}} = \frac{3g}{4}$$

$$T_1 = 2\pi\sqrt{\frac{\ell_1}{g_{\text{eff}}}} \quad \ell_1 = \ell + \frac{\ell}{3} = \frac{4\ell}{3}, \quad \ell_{\text{eff}} = \frac{3g}{4}$$

By Solving

$$T_1 = \frac{4}{3} 2\pi\sqrt{\ell/g}$$

$$T_1 = \frac{4T}{3}$$

- 18.** A free electron of 2.6eV energy collides with a H^+ ion. This results in the formation of a hydrogen atom in the first excited state and a photon is released. Find the frequency of the emitted photon ($h = 6.6 \times 10^{-34} \text{ J s}$)
(1) $1.45 \times 10^{16} \text{ MHz}$ (2) $0.19 \times 10^{15} \text{ MHz}$ (3) $1.45 \times 10^9 \text{ MHz}$ (4) $9.0 \times 10^{27} \text{ MHz}$

Sol. (3)

For every large distance P.E. = 0

& total energy = 2.6 + 0 = 2.6eV

Finally in first excited state of H atom total energy

= -3.4 eV

Loss in total energy = 2.6 - (-3.4)
= 6eV

It is emitted as photon

$$\lambda = \frac{1240}{6} = 206 \text{ nm}$$

$$f = \frac{3 \times 10^8}{206 \times 10^{-9}} = 1.45 \times 10^{15} \text{ Hz}$$
$$= 1.45 \times 10^9 \text{ MHz}$$

- 19.** A mixture of hydrogen and oxygen has volume 500 cm^3 , temperature 300 K, pressure 400 kPa and mass 0.76 g. The ratio of masses of oxygen to hydrogen will be:
(1) 3:16 (2) 16:3 (3) 3 : 8 (4) 8:3

Sol. (2)

$$PV = nRT$$

$$400 \times 10^3 \times 500 \times 10^{-6} = n \left(\frac{25}{3} \right) (300)$$

$$n = \frac{2}{25}$$

$$n = n_1 + n_2$$

$$\frac{2}{25} = \frac{M_1}{2} + \frac{M_2}{32}$$

Also $M_1 + M_2 = 0.76 \text{ gm}$

$$\frac{M_2}{M_1} = \frac{16}{3}$$

- 20.** If R_E be the radius of Earth, then the ratio between the acceleration due to gravity at a depth 'r' below and height 'r' above the earth surface is:

(Given : $r < R_E$)

(1) $1 + \frac{r}{R_E} - \frac{r^2}{R_E^2} - \frac{r^3}{R_E^3}$

(2) $1 + \frac{r}{R_E} - \frac{r^2}{R_E^2} + \frac{r^3}{R_E^3}$

(3) $1 - \frac{r}{R_E} - \frac{r^2}{R_E^2} - \frac{r^3}{R_E^3}$

(4) $1 + \frac{r}{R_E} + \frac{r^2}{R_E^2} + \frac{r^3}{R_E^3}$

Sol. (1)

$$g_{\text{up}} = \frac{g}{\left(1 + \frac{r}{R}\right)^2}$$

$$g_{\text{down}} = \frac{g}{\left(1 - \frac{r}{R}\right)^2}$$

$$\frac{g_{\text{down}}}{g_{\text{up}}} = \left(1 - \frac{r}{R}\right)^2 \left(1 + \frac{r}{R}\right)^2$$

$$= \left(1 - \frac{r}{R}\right)^2 \left(1 + \frac{2r}{R} + \frac{r^2}{R^2}\right)$$

$$= 1 + \frac{r}{R} - \frac{r^2}{R^2} - \frac{r^3}{R^3}$$

Section B

- 1.** A particle is moving with constant acceleration 'a'. Following graph show v^2 versus x(displacement) plot. The acceleration of the particle is _____ m/s^2 .

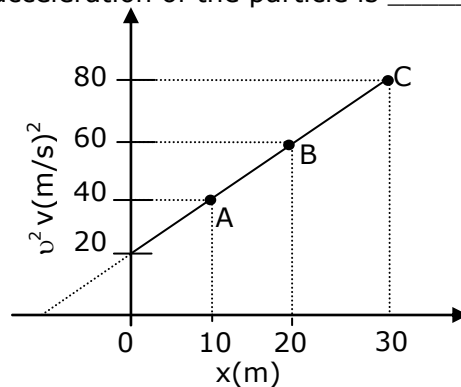

Sol. 1

$$y = mx + C$$

$$v^2 = \frac{20}{10}x + 20$$

$$v^2 = 2x + 20$$

$$2v \frac{dv}{dx} = 2$$

$$\therefore a = v \frac{dv}{dx} = 1$$

2. In a Young's double slit experiment, the slits are separated by 0.3 mm and the screen is 1.5 m away from the plane of slits. Distance between fourth bright fringes on both sides of central bright fringe is 2.4 cm. The frequency of light used is _____ $\times 10^{14}$ Hz.

Sol. 5

$$8\beta = 2.4 \text{ cm}$$

$$\frac{8\lambda\Delta}{d} = 2.4 \text{ cm}$$

$$\frac{8 \times 1.5 \times c}{0.3 \times 10^{-3} \times f} = 2.4 \times 10^{-2}$$

$$f = 5 \times 10^{14} \text{ Hz}$$

3. At very high frequencies, the effective impedance of the given circuit will be _____ Ω .

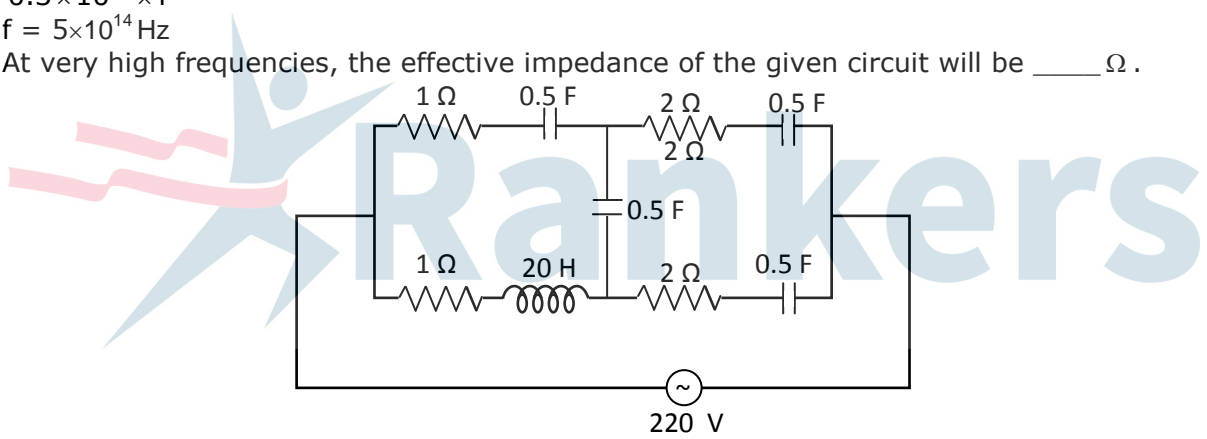

Sol. 2

$$X_L = 2\pi fL$$

f is very large
 $\therefore X_L$ is very large hence open circuit.

$$X_C = \frac{1}{2\pi fC}$$

f is very large.
 $\therefore X_C$ is very small, hence short circuit
 Final circuit

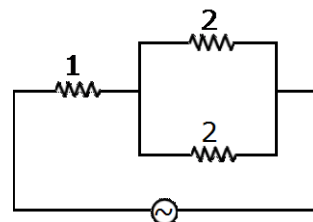

$$Z_{eq} = 1 + \frac{2 \times 2}{2 + 2} = 2$$

4. Cross-section view of a prism is the equilateral triangle ABC shown in the figure. The minimum deviation is observed using this prism when the angle of incidence is equal to the prism angle. The time taken by light to travel from P (midpoint of BC) to A is _____ $\times 10^{-10}$ s. (Given, speed of light in vacuum = 3×10^8 m/s and $\cos 30^\circ = \frac{\sqrt{3}}{2}$)

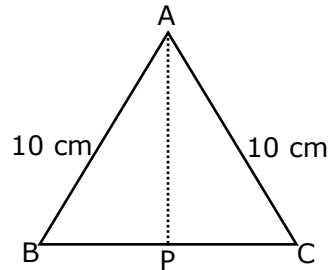

Sol. 5

$$i = A = 60^\circ$$

$$\delta_{\min} = 2i - A$$

$$= 2 \times 60^\circ - 60^\circ = 60^\circ$$

$$\mu = \frac{\sin^{-1}(\frac{\delta_{\min} + A}{2})}{\sin^{-1}(\frac{A}{2})}$$

$$= \sqrt{3}$$

$$V_{\text{prism}} = \frac{3 \times 10^8}{\sqrt{3}}$$

$$AP = 10 \times 10^{-2} \times \frac{\sqrt{3}}{2}$$

$$\text{time} = \frac{5 \times 10^{-2}}{3 \times 10^8} \times \sqrt{3} \times \sqrt{3}$$

$$= 5 \times 10^{-10} \text{ sec}$$

$$\text{Ans.} = 5$$

5. A sample of gas with $\gamma = 1.5$ is taken through an adiabatic process in which the volume is compressed from 1200 cm^3 to 300 cm^3 . If the initial pressure is 200 kPa. The absolute value of the workdone by the gas in the process = _____ J.

Sol. 480

$$\gamma = 1.5$$

$$p_1 v_1^\gamma = p_2 v_2^\gamma$$

$$(200) (1200)^{1.5} = p_2 (300)^{1.5}$$

$$p_2 = 200 [4]^{3/2} = 1600 \text{ kPa}$$

$$|\text{W.D.}| = \frac{p_2 v_2 - p_1 v_1}{\gamma - 1} = \left(\frac{480 - 240}{0.5} \right) = 480 \text{ J}$$

6. The diameter of a spherical bob is measured using a vernier callipers. 9 divisions of the main scale, in the vernier callipers, are equal to 10 divisions of vernier scale. One main scale division is 1 mm. The main scale reading is 10 mm and 8th division of vernier scale was found to coincide exactly with one of the main scale division. If the given vernier callipers has positive zero error of 0.04 cm, then the radius of the bob is _____ $\times 10^{-2}$ cm.

Sol. 52

$$9 \text{ MSD} = 10 \text{ VSD}$$

$$9 \times 1 \text{ mm} = 10 \text{ VSD}$$

$$\therefore 1 \text{ VSD} = 0.9 \text{ mm}$$

$$\text{LC} = 1 \text{ MSD} - 1 \text{ VSD} = 0.1 \text{ mm}$$

$$\text{Reading} = \text{MSR} + \text{VSR} \times \text{LC}$$

$$10 + 8 \times 0.1 = 10.8 \text{ mm}$$

$$\text{Actual reading} = 10.8 - 0.4 = 10.4 \text{ mm}$$

$$\text{Radius} = \frac{d}{2} = \frac{10.4}{2} = 5.2 \text{ mm}$$

$$= 52 \times 10^{-2} \text{ cm}$$

7. A resistor dissipates 192 J of energy in 1 s when a current of 4 A is passed through it. Now, when the current is doubled, the amount of thermal energy dissipated in 5 s is _____ J.

Sol. 3840

$$E = i^2 R t$$

$$192 = 16 (R) (1)$$

$$R = 12 \Omega$$

$$E^1 = (8)^2 (12) (5)$$

$$= 3840 \text{ J}$$

8. A long solenoid with 1000 turns/m has a core material with relative permeability 500 and volume 10^3 cm^3 . If the core material is replaced by another material having relative permeability of 750 with same volume maintaining same current of 0.75 A in the solenoid, the fractional change in the magnetic moment of the core would be approximately $\left(\frac{x}{499}\right)$. Find the

value of x.

Sol. 250

$$\frac{\Delta M}{M} - \frac{\Delta \mu}{\mu} = \frac{250}{500} = \frac{1}{2}$$

$$\frac{1}{2} = \frac{x}{499} \Rightarrow x = 250$$

9. A bandwidth of 6 MHz is available for A.M. transmission. If the maximum audio signal frequency used for modulating the carrier wave is not to exceed 6 kHz. The number of stations that can be broadcasted within this band simultaneously without interfering with each other will be _____.

Sol. 500

$$\text{Signal bandwidth} = 2 \text{ fm}$$

$$= 12 \text{ kHz}$$

$$\therefore N = \frac{6 \text{ MHz}}{12 \text{ kHz}} = \frac{6 \times 10^6}{12 \times 10^3} = 500$$

- 10.** A parallel plate capacitor of capacitance $200 \mu\text{F}$ is connected to a battery of 200 V . A dielectric slab of dielectric constant 2 is now inserted into the space between plates of capacitor while the battery remain connected. The change in the electrostatic energy in the capacitor will be _____ J.

Sol. 4

$$\Delta U = \frac{1}{2}(\Delta C)V^2$$

$$\Delta U = \frac{1}{2}(KC - C)V^2$$

$$\Delta U = \frac{1}{2}(2 - 1)CV^2$$

$$\Delta U = \frac{1}{2} \times 200 \times 10^{-6} \times 200 \times 200$$

$$\Delta U = 4\text{J}$$

