

**JEE–MAIN EXAMINATION – JUNE, 2022**

**26 June S - 01 Paper Solution**

**SECTION-A**

1. An expression for a dimensionless quantity P is given by  $P = \frac{\alpha}{\beta} \log_e \left( \frac{kt}{\beta x} \right)$ ; where  $\alpha$  and  $\beta$  are constants, x is distance ; k is Boltzmann constant and t is the temperature. Then the dimensions of  $\alpha$  will be :

- (A)  $[M^0L^{-1}T^0]$                       (B)  $[ML^0T^{-2}]$   
 (C)  $[MLT^{-2}]$                         (D)  $[ML^2T^{-2}]$

**Ans. (C)**

**Sol.**  $P = \frac{\alpha}{\beta} \log_e \left( \frac{kt}{\beta x} \right)$

$$\frac{kt}{\beta x} = 1 \Rightarrow \beta = \frac{kt}{x} = \frac{ML^2T^{-2}}{L}$$

$$\left( \because E = \frac{1}{2} kt \right)$$

As P is dimensionless

$$\Rightarrow [\alpha] = [\beta] = [MLT^{-2}]$$

2. A person is standing in an elevator. In which situation, he experiences weight loss ?

- (A) When the elevator moves upward with constant acceleration  
 (B) When the elevator moves downward with constant acceleration  
 (C) When the elevator moves upward with uniform velocity  
 (D) When the elevator moves downward with uniform velocity

**Ans. (B)**

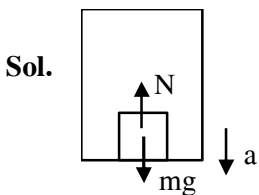

$$mg - N = ma$$

$$\Rightarrow N = m(g - a)$$

$\therefore$  Person experiences weightloss, when acceleration of lift is downward.

3. An object is thrown vertically upwards. At its maximum height, which of the following quantity becomes zero ?

- (A) Momentum                      (B) Potential energy  
 (C) Acceleration                      (D) Force

**Ans. (A)**

**Sol.** At maximum height,  $V = 0$

$\therefore$  Momentum of object is zero.

4. A ball is released from rest from point P of a smooth semi-spherical vessel as shown in figure. The ratio of the centripetal force and normal reaction on the ball at point Q is A while angular position of point Q is  $\alpha$  with respect to point P. Which of the following graphs represent the correct relation between A and  $\alpha$  when ball goes from Q to R ?

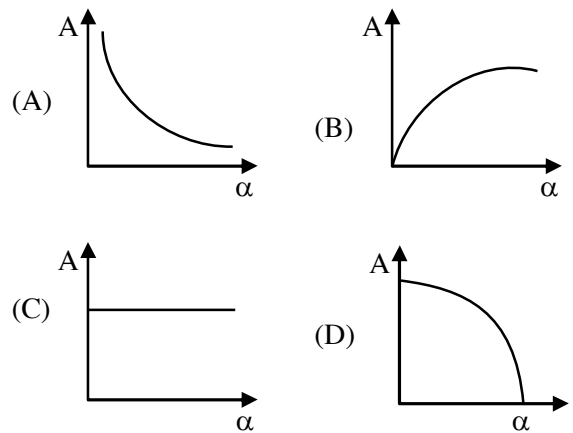
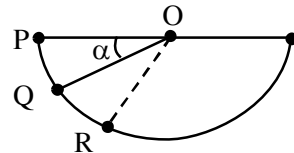

**Ans. (C)**

**Sol.**  $V = \sqrt{2gR \sin \alpha}$

$$N - mg \sin \alpha = \frac{mv^2}{R} = 2mg \sin \alpha$$

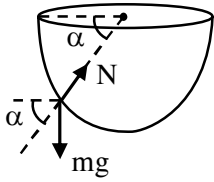

$$\frac{N}{2mg \sin \alpha} = \frac{1}{2} + 1 = \frac{3}{2}$$

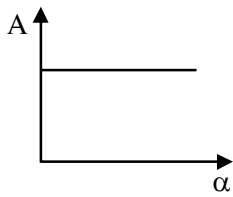

$\Rightarrow A = \text{constant}$

5. A thin circular ring of mass  $M$  and radius  $R$  is rotating with a constant angular velocity  $2 \text{ rads}^{-1}$  in a horizontal plane about an axis vertical to its plane and passing through the center of the ring. If two objects each of mass  $m$  be attached gently to the opposite ends of a diameter of ring, the ring will then rotate with an angular velocity (in  $\text{rads}^{-1}$ ).

- (A)  $\frac{M}{(M+m)}$                       (B)  $\frac{(M+2m)}{2M}$   
 (C)  $\frac{2M}{(M+2m)}$                       (D)  $\frac{2(M+2m)}{M}$

**Ans. (C)**

**Sol.** Applying conservation of angular momentum

$$MR^2\omega = (MR^2 + 2mR^2)\omega'$$

$$\omega' = \frac{2M}{M+2m}$$

6. The variation of acceleration due to gravity ( $g$ ) with distance ( $r$ ) from the center of the earth is correctly represented by : (Given  $R =$  radius of earth)

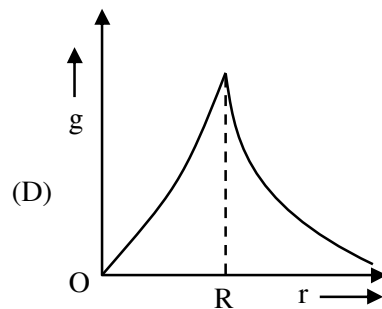
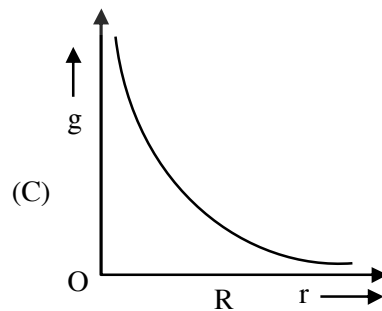
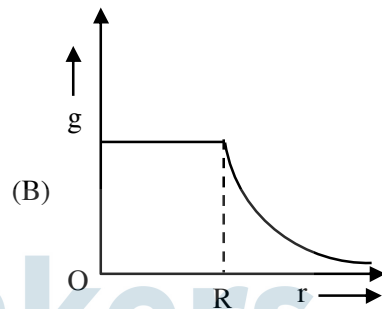
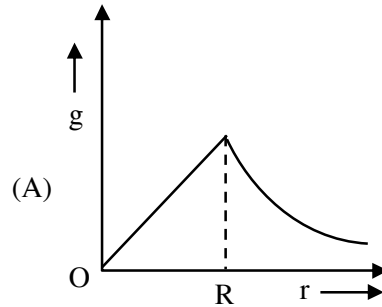

**Ans. (A)**

**Sol.** 
$$g = \begin{cases} \frac{GMr}{R^3}, & r \leq R \\ \frac{GM}{r^2}, & r \geq R \end{cases}$$

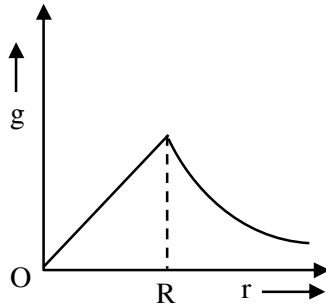

7. The efficiency of a Carnot's engine, working between steam point and ice point, will be :

- (A) 26.81%                      (B) 37.81%  
 (C) 47.81%                      (D) 57.81%

**Ans. (A)**

**Sol.** 
$$\eta = \left[ 1 - \frac{T_L}{T_n} \right] \times 100\%$$

$T_L = 0^\circ\text{C} = 273\text{K}, T_n = 373\text{K}$

$\therefore \eta = 26.809\%$

8. Time period of a simple pendulum in a stationary lift is 'T'. If the lift accelerates with  $\frac{g}{6}$  vertically

upwards then the time period will be :

(where g = acceleration due to gravity)

- (A)  $\sqrt{\frac{6}{5}}T$                       (B)  $\sqrt{\frac{5}{6}}T$   
 (C)  $\sqrt{\frac{6}{7}}T$                       (D)  $\sqrt{\frac{7}{6}}T$

**Ans. (C)**

**Sol.** 
$$T = 2\pi \sqrt{\frac{\ell}{g_{\text{eff}}}}$$

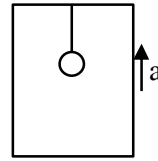

(a) when  $a = 0$ ,  $T = 2\pi \sqrt{\frac{\ell}{g}}$

(b) when  $a = \frac{g}{6}$ ,  $T' = 2\pi \sqrt{\frac{\ell}{g + \frac{g}{6}}}$

$\therefore T' = \sqrt{\frac{6}{7}}T$

9. A thermally insulated vessel contains an ideal gas of molecular mass M and ratio of specific heats 1.4. Vessel is moving with speed v and is suddenly brought to rest. Assuming no heat is lost to the surrounding and vessel temperature of the gas increases by : (R = universal gas constant)

- (A)  $\frac{Mv^2}{7R}$   
 (B)  $\frac{Mv^2}{5R}$   
 (C)  $2 \frac{Mv^2}{7R}$   
 (D)  $7 \frac{Mv^2}{5R}$

**Ans. (B)**

**Sol.** 
$$\frac{C_p}{C_v} = 1 + \frac{2}{F} = 1.4 \Rightarrow F = 5$$

By conservation of energy

$$\frac{F}{2} nR\Delta T = \frac{1}{2} [nm] v^2$$

$$\Delta T = \frac{mv^2}{FR} = \frac{Mv^2}{5R}$$

10. Two capacitors having capacitance  $C_1$  and  $C_2$  respectively are connected as shown in figure. Initially, capacitor  $C_1$  is charged to a potential difference  $V$  volt by a battery. The battery is then removed and the charged capacitor  $C_1$  is now connected to uncharged capacitor  $C_2$  by closing the switch  $S$ . The amount of charge on the capacitor  $C_2$ , after equilibrium is :

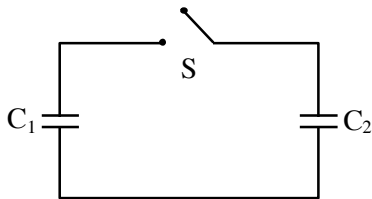

- (A)  $\frac{C_1 C_2}{(C_1 + C_2)} V$       (B)  $\frac{(C_1 + C_2)}{C_1 C_2} V$   
 (C)  $(C_1 + C_2)V$       (D)  $(C_1 - C_2)V$

**Ans. (A)**

**Sol.** Charge on capacitor  $C_2$

$$= \frac{C_2 \times Q_{\text{total}}}{C_{\text{total}}} = \frac{C_2 [C_1 V]}{C_1 + C_2} = \frac{C_1 C_2 V}{C_1 + C_2}$$

11. **Assertion (A) :** Non-polar materials do not have permanent dipole moment.

**Reason (R) :** When a non-polar material is placed in an electric field, the centre of the positive charge distribution of its individual atom or molecule coincides with the centre of the negative charge distribution.

In the light of above statements, choose the most appropriate answer from the options given below.

- (A) Both (A) and (R) are correct and (R) is the correct explanation of (A).  
 (B) Both (A) and (R) are correct and (R) is not the correct explanation of (A).  
 (C) (A) is correct but (R) is not correct.  
 (D) (A) is not correct but (R) is correct.

**Ans. (C)**

**Sol. S1 :** In nonpolar molecules, centre of +ve charge coincides with centre of -ve charge, hence net dipole moment is zero.

**S2 :** When non polar material is placed in external field, centre of charges does not coincide, hence give non zero moment in field

12. The magnetic flux through a coil perpendicular to its plane is varying according to the relation  $\phi = (5t^3 + 4t + 2t - 5)$  Weber. If the resistance of the coil is 5 ohm, then the induced current through the coil at  $t = 2$  sec will be:

- (A) 15.6 A      (B) 16.6 A  
 (C) 17.6 A      (D) 18.6 A

**Ans. (A)**

**Sol.**  $\phi = 5t^3 + 4t^2 + 2t - 5$

$$|e| = \frac{d\phi}{dt} = 15t^2 + 8t + 2$$

$$\text{At } t = 2, |e| = 15 \times 2^2 + 8 \times 2 + 2$$

$$\Rightarrow e = 78V \Rightarrow I = \frac{e}{R} = \frac{78}{5} = 15.60$$

13. An aluminium wire is stretched to make its length, 04% larger. Then percentage change in resistance is:

- (A) 0.4 %      (B) 0.2 %  
 (C) 0.8 %      (D) 0.6 %

**Ans. (C)**

**Sol.**  $R = \frac{\rho \ell}{A}$

$$\frac{\Delta R}{R} = \frac{\Delta \ell}{\ell} - \frac{\Delta A}{A}$$

$$\ell A = k$$

$$\frac{\Delta \ell}{\ell} + \frac{\Delta A}{A} = 0$$

$$\frac{\Delta R}{R} = \frac{2\Delta \ell}{\ell}$$

$$\frac{\Delta R}{R} = 2 \times 0.4 = 0.8\%$$

14. A proton and an alpha particle of the same enter in a uniform magnetic field which is acting perpendicular to their direction of motion. The ratio of the circular paths described by the alpha particle and proton is:

- (A) 1 : 4                                      (B) 4 : 1  
 (C) 2 : 1                                      (D) 1 : 2

**Ans. (C)**

**Sol.**  $\frac{R_\alpha}{R_p} = \frac{M_\alpha}{M_p} \times \frac{q_p}{q_\alpha}$

$$\frac{R_\alpha}{R_p} = \frac{4}{1} \times \frac{1}{2} = 2$$

15. If electric field intensity of a uniform plane electromagnetic wave is given as

$$E = -301.6 \sin(kz - \omega t) \hat{a}_x + 452.4 \sin(kz - \omega t) \hat{a}_y \frac{V}{m}$$

Then, magnetic intensity H of this wave in  $Am^{-1}$  will be:

[Given: Speed of light in vacuum  $c = 3 \times 10^8 \text{ ms}^{-1}$ , permeability of vacuum  $\mu_0 = 4\pi \times 10^{-7} \text{ NA}^{-2}$ ]

- (A)  $+0.8 \sin(kz - \omega t) \hat{a}_y + 0.8 \sin(kz - \omega t) \hat{a}_x$   
 (B)  $+1.0 \times 10^{-6} \sin(kz - \omega t) \hat{a}_y + 1.5 \times 10^{-6} \sin(kz - \omega t) \hat{a}_x$   
 (C)  $-0.8 \sin(kz - \omega t) \hat{a}_y - 1.2 \sin(kz - \omega t) \hat{a}_x$   
 (D)  $-1.0 \times 10^{-6} \sin(kz - \omega t) \hat{a}_y - 1.5 \times 10^{-6} \sin(kz - \omega t) \hat{a}_x$

**Ans. (C)**

**Sol.**  $\vec{E} = 301.6 \sin(kz - \omega t) (-\hat{a}_x) + 452.4 \sin(kz - \omega t) \hat{a}_y$

$$\vec{B} = \frac{301.6}{c} \sin(kz - \omega t) (-\hat{a}_y)$$

$$+ \frac{452.4}{c} \sin(kz - \omega t) (-\hat{a}_x)$$

$$\vec{H} = \frac{\vec{B}}{\mu_0} = \frac{301.6}{\mu_0 c} \sin(kz - \omega t) (-\hat{a}_y)$$

$$+ \frac{452.4}{\mu_0 c} \sin(kz - \omega t) (-\hat{a}_x)$$

$$\vec{H} = -0.8 \sin(kz - \omega t) \hat{a}_y - 1.2 \sin(kz - \omega t) \hat{a}_x$$

For direction

$$\vec{E} \times \vec{B} \text{ is direction of } \vec{C}$$

$$\text{For first part } \hat{E} = -\hat{i}, \hat{B} = ?$$

$$\hat{E} \times \hat{B} = \hat{k} \Rightarrow \hat{B} = -\hat{j}$$

Similarly for second

$$\hat{E} = \hat{j}, \hat{B} = ?$$

$$\hat{E} \times \hat{B} = \hat{k} \Rightarrow \hat{B} = -\hat{i}$$

16. In free space, an electromagnetic wave of 3 GHz of 3 GHz frequency strikes over the edge of an object of size  $\frac{\lambda}{100}$ , where  $\lambda$  is the wavelength of the wave in free space. The phenomenon, which happens there will be:

- (A) Reflection                                      (B) Refraction  
 (C) Diffraction                                      (D) Scattering

**Ans. (D)**

**Sol.**  $\frac{a}{\lambda} = \frac{1}{100}$

For reflection size of obstacle must be much larger than wavelength, for diffraction size should be order of wavelength.

Since the object is of size  $\frac{\lambda}{100}$ , much smaller than wavelength, so scattering will occur.

17. An electron with speed  $v$  and a photon with speed  $c$  have the same de-Broglie wavelength. If the kinetic energy and momentum of electron are  $E_e$  and  $p_e$  and that of photon are  $E_{ph}$  and  $p_{ph}$  respectively. Which of the following is correct?

- (A)  $\frac{E_e}{E_{ph}} = \frac{2c}{v}$                       (B)  $\frac{E_e}{E_{ph}} = \frac{v}{2c}$   
 (C)  $\frac{p_e}{p_{ph}} = \frac{2c}{v}$                       (D)  $\frac{p_e}{p_{ph}} = \frac{v}{2c}$

Ans. (B)

Sol.  $\lambda_e = \lambda_{\text{photon}}$

$$\frac{h}{mv} = \frac{h}{P_{\text{photon}}} \Rightarrow P_{\text{photon}} = mv$$

$$\frac{E_e}{E_{ph}} = \frac{\frac{1}{2}mv^2}{\frac{hc}{\lambda}} = \frac{1}{2} \frac{mv}{P_{ph}} \times v = \frac{v}{2c}$$

18. How many alpha and beta particles are emitted when Uranium  ${}_{92}\text{U}^{238}$  decays to lead  ${}_{82}\text{Pb}^{206}$ ?

- (A) 3 alpha particles and 5 beta particles  
 (B) 6 alpha particles and 4 beta particles  
 (C) 4 alpha particles and 5 beta particles  
 (D) 8 alpha particles and 6 beta particles

Ans. (D)

Sol.  ${}_{92}^{238}\text{U} \rightarrow [8]_2^4\text{He} + [6]_{-1}^0\text{e} + {}_{82}^{206}\text{Pb}$

8 $\alpha$  particles and 6 $\beta$  particles are emitted.

19. The I-V characteristics of a p-n junction diode in forward bias is shown in the figure. The ratio of dynamic resistance, corresponding to forward bias voltages of 2V and 4V respectively, is :

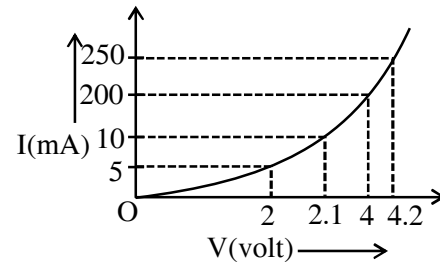

- (A) 1 : 2                                      (B) 5 : 1  
 (C) 1 : 40                                      (D) 20 : 1

Ans. (B)

Sol.  $R = \frac{\Delta V}{\Delta i}$

$$\frac{R_1}{R_2} = \frac{\Delta v_1 \Delta i_2}{\Delta v_2 \Delta i_1} = \frac{0.1 \times 50}{0.2 \times 5} = 5$$

20. Choose the correct statement for amplitude modulation:

- (A) Amplitude of modulating is varied in accordance with the information signal.  
 (B) Amplitude of modulated is varied in accordance with the information signal.  
 (C) Amplitude of carrier signal is varied in accordance with the information signal.  
 (D) Amplitude of modulated is varied in accordance with the modulating signal.

Ans. (C)

Sol. In amplitude modulation the amplitude of high frequency carrier wave is varied in accordance with message signal

**SECTION-B**

1. A fighter jet is flying horizontally at a certain altitude with a speed of  $200 \text{ ms}^{-1}$ . When it passes directly overhead an anti-aircraft gun, bullet is fired from the gun, at an angle  $\theta$  with the horizontal, to hit the jet. If the bullet speed is  $400 \text{ m/s}$ , the value of  $\theta$  will be .....  $^\circ$ .

**Ans. (60)**

- Sol.** Both should have same horizontal component of velocity

$$200 = 400 \cos \theta$$

$$\theta = 60^\circ$$

2. A ball of mass  $0.5 \text{ kg}$  is dropped from the height of  $10 \text{ m}$ . The height, at which the magnitude of velocity becomes equal to the magnitude of acceleration due to gravity, is .....  $\text{m}$ . (Use  $g = 10 \text{ m/s}^2$ ).

**Ans. (5)**

- Sol.**  $v^2 = u^2 + 2as$

$$100 = 0 + 2(10)s$$

$$S = 5 \text{ m}$$

$$\text{Height from ground} = 10 - 5 = 5 \text{ m}$$

3. The elastic behaviour of material for linear stress and linear strain, is shown in the figure. The energy density for a linear strain of  $5 \times 10^{-4}$  is .....  $\text{kJ/m}^3$ . Assume that material is elastic upto the linear strain of  $5 \times 10^{-4}$ .

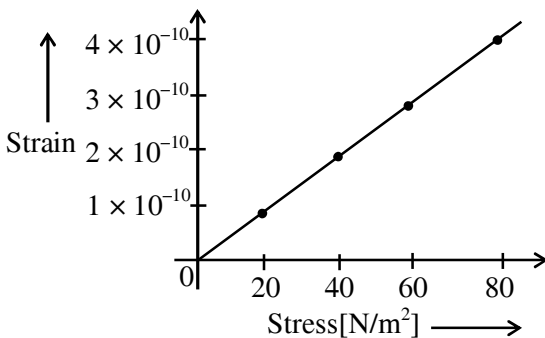

**Ans. (25)**

- Sol.**  $y = \frac{\text{stress}}{\text{strain}} = 2.0 \times 10^{10}$

$$\text{Energy density} = \frac{1}{2} \text{stress} \times \text{strain}$$

$$= \frac{1}{2} (\text{strain})^2 y = \frac{1}{2} (5 \times 10^{-4})^2 \times 2.0 \times 10^{10}$$

$$= 25 \times 10^2 \times 10 = 25 \frac{\text{kJ}}{\text{m}^3}$$

**Ans. 25**

4. The elongation of a wire on the surface of the earth is  $10^{-4} \text{ m}$ . The same wire of same dimensions is elongated by  $6 \times 10^{-5} \text{ m}$  on another planet. The acceleration due to gravity on the planet will be .....  $\text{ms}^{-2}$ . (Take acceleration due to gravity on the surface of earth =  $10 \text{ m/s}^2$ )

**Ans. (6)**

- Sol.**  $\Delta l \propto g$

$$\frac{\Delta l_{\text{earth}}}{\Delta l_{\text{planet}}} = \frac{g_{\text{earth}}}{g_{\text{planet}}} = \frac{10^{-4}}{6 \times 10^{-5}}$$

$$g_{\text{planet}} = 6 \text{ m/s}^2$$

**Ans. 6.00**

5. A  $10 \Omega$ ,  $20 \text{ mH}$  coil carrying constant current is connected to a battery of  $20 \text{ V}$  through a switch is opened current becomes zero in  $100 \mu\text{s}$ . The average emf induced in the coil is .....  $\text{V}$ .

**Ans. (400)**

- Sol.**  $\langle \epsilon \rangle = \frac{\int \epsilon dt}{\int dt} = \frac{\int (L di / dt) dt}{\int dt} = \frac{L \int di}{\int dt}$

$$\langle \epsilon \rangle = \frac{L \Delta i}{\Delta t}$$

$$i_0 = \frac{V}{R} = \frac{20}{10} = 2 \text{ A}, \text{ if } i = 0 \text{ A}$$

$$T = 100 \mu\text{s}, L = 20 \text{ mH}$$

$$\langle \epsilon \rangle = \frac{20 \times 10^{-3} \times (2 - 0)}{100 \times 10^{-6}}$$

$$= \frac{2 \times 10^3}{5}$$

$$\langle \epsilon \rangle = 400 \text{ V}$$

6. A light ray is incident, at an incident angle  $\theta_1$ , on the system of two plane mirrors  $M_1$  and  $M_2$  having an inclination angle  $75^\circ$  between them (as shown in figure). After reflecting from mirror  $M_1$  it gets reflected back by the mirror  $M_2$  with an angle of reflection  $30^\circ$ . The total deviation of the ray will be ..... degree.

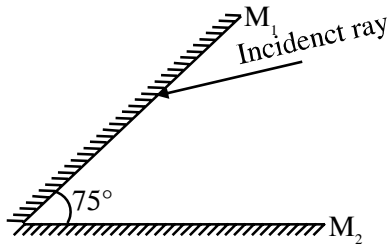

Ans. (210)

Sol.  $\delta_{\text{total}} = 360^\circ - 2\theta$

$= 360^\circ - 2 \times 75^\circ$

$\delta_{\text{total}} = 210^\circ$

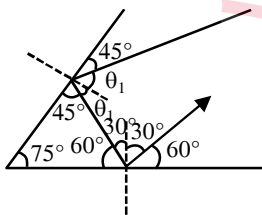

$\theta_1 = 45^\circ$

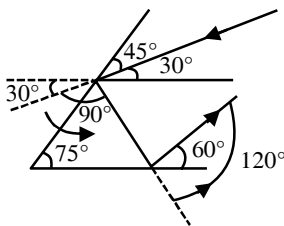

$\delta = 120^\circ + 90^\circ = 210^\circ$

7. In a vernier callipers, each cm on the main scale is divided into 20 equal parts. If tenth vernier scale division coincides with ninth main scale division. Then the value of vernier constant will be .....  $\times 10^{-2}$  mm.

Ans. (5)

Sol.  $20 \text{ MSD} = 1 \text{ cm}$

$1 \text{ MSD} = \frac{1}{20} \text{ cm}$

$10 \text{ VSD} = 9 \text{ MSD}$

$1 \text{ VSD} = \frac{9}{10} \text{ MSD}$

$= \frac{9}{10} \times \frac{1}{20} \text{ cm}$

$1 \text{ VSD} = \frac{9}{200} \text{ cm}$

$VC = 1 \text{ MSD} - 1 \text{ VSD}$

$= \frac{1}{20} \text{ cm} - \frac{9}{200} \text{ cm}$

$= \frac{1}{200} \times 10 \text{ mm}$

$VC = 5 \times 10^{-2} \text{ mm}$

Ans. 5

8. As per the given circuit, the value of current through the battery will be ..... A.

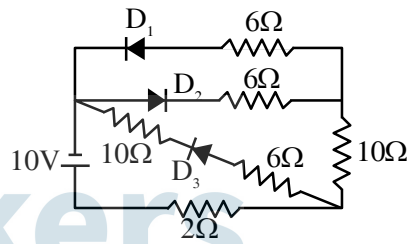

Ans. (1)

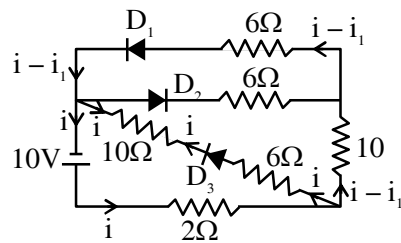

Sol.

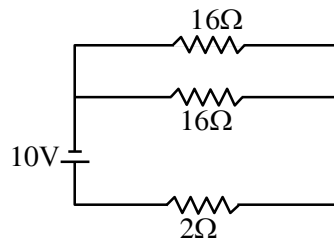

$V = IR_{\text{net}}$

$10 = I \times 10$

$I = 1 \text{ A}$

Ans. 1



9. A 110 V , 50 Hz, AC source is connected in the circuit (as shown in figure). The current through the resistance  $55 \Omega$ , at resonance in the circuit, will be ..... A.

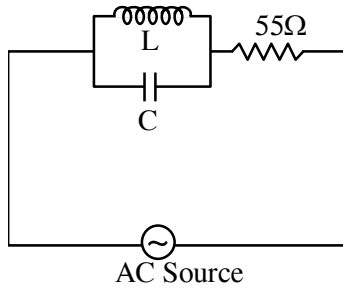

Ans. (0)

Sol. At resonance  $I_L = I_C$

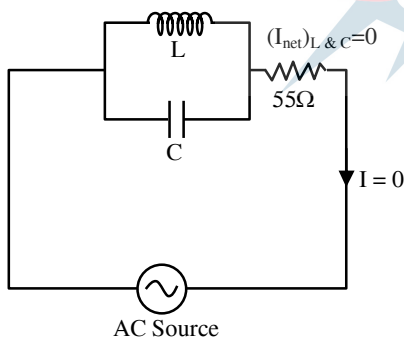

Alternatively,

$$\frac{1}{Z} = \sqrt{\left(\frac{1}{X_L} - \frac{1}{X_C}\right)^2}$$

At resonance,  $X_L = X_C$  &  $Z \rightarrow \infty$

$\therefore Z_{\text{total circuit}} \rightarrow \infty$  i.e,  $I = 0$

Ans. 0

10. An ideal fluid of density  $800 \text{ kgm}^{-3}$ , flows smoothly through a bent pipe (as shown in figure) that tapers in cross-sectional area from  $a$  to  $\frac{a}{2}$ . The pressure difference between the wide and narrow sections of pipe is  $4100 \text{ Pa}$ . At wider section, the velocity of fluid is  $\frac{\sqrt{x}}{6} \text{ ms}^{-1}$  for  $x = \dots\dots\dots$

(Given  $g = 10 \text{ m}^{-2}$ )

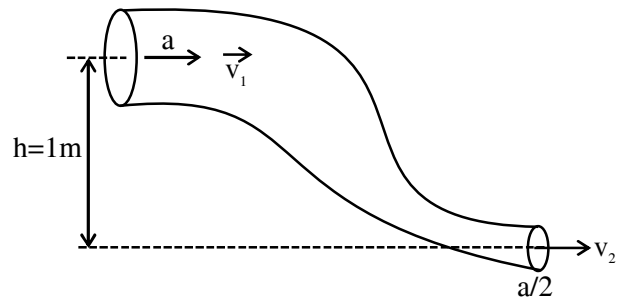

Ans. (363)

Sol. From continuity equation

$$av_1 = \frac{a}{2}v_2$$

$$v_2 = 2v_1$$

From Bernoulli's theorem,

$$P_1 + \rho gh_1 + \frac{1}{2}\rho v_1^2 = P_2 + \rho gh_2 + \frac{1}{2}\rho v_2^2$$

$$P_1 - P_2 = \rho \left[ \left( \frac{v_2^2 - v_1^2}{2} \right) + g(h_2 - h_1) \right]$$

$$4100 = 800 \left[ \left( \frac{4v_1^2 - v_1^2}{2} \right) + 10 \times (0 - 1) \right]$$

$$\frac{41}{8} + 10 = \frac{3v_1^2}{2}$$

$$\frac{121}{8} \times \frac{2}{3} = v_1^2$$

$$v_1 = \sqrt{\frac{121}{4 \times 3} \times \frac{3}{3}}$$

$$v_1 = \frac{\sqrt{363}}{6} \text{ m/s}$$

$X = 363$ .